

Chapter 1

1.1 Data representation



S No	Learning Outcome	To Read	Have Read	To Revise	Have Revised	Prepared
	1.1.1: Binary systems					
1	Recognize the use of binary numbers in computer systems					
2	Denary-to-binary and binary-to-denary conversion					
3	Concept of a byte and how the byte is used to measure memory size					
4	Use binary in computer registers for a given application (such as in robotics, digital instruments and counting systems)					
	1.1.2: Hexadecimal					
5	Represent integers as hexadecimal numbers					
6	Reasons for choosing hexadecimal to represent numbers					
7	Convert positive hexadecimal integers to and from denary					
8	Convert positive hexadecimal integers to and from binary					
9	Represent numbers stored in registers and main memory as hexadecimal					
10	Identify current uses of hexadecimal numbers in computing, such as defining colours in Hypertext Markup Language (HTML), Media Access Control (MAC) addresses, assembly languages and machine code, debugging					
	1.1.3: Data storage					
43	File formats sound (music), pictures, video, text and numbers					
44	Identify and describe methods of error detection and correction, such as parity checks, check digits, checksums and Automatic Repeat requests (ARQ)					
45	Concept of (MIDI) files, jpeg files, MP3 and MP4 files					
46	File compression (lossless and lossy compression algorithms) applied to music/video, photos and text files					

Chapter at a glance:

Computer is an electronic data processing machine, accepts data, processes according to given instruction and produces resulting information.

Data is set of raw facts and figures required to solve a problem.

Analogue Data consists on continuous values, found in our daily life. E.g. Weight, Temperature etc.

Digital Data consists of two discrete values like 0 and 1, used in internal circuitry of computer.

The basic building block in all computers is the **binary number system**.

A **binary digit** is commonly referred to as a **BIT**; 8 bits are usually referred to as a **BYTE**.

The byte is the **smallest unit of memory** in a computer.

Binary-to-Decimal & Denary-to-Binary Conversion –use binary notation (place values) i.e. 128, 64, 32, 16, 8, 4, 2, 1.

For **Binary-to-Hexadecimal** conversion firstly groups of 4 bits are made from right to left and each group is converted separately using 8, 4, 2, 1 notation.

For **Hexadecimal-to-Binary** conversion each hex digit is separated by other and then each hex digit is converted separately using 8 4 2 1 notation.

For **Denary-to-Hexadecimal** conversion LCM of the denary number is taken.

For Hexadecimal-to-Denary conversion hexadecimal notation (place value) is used e.g. 4096

256 16 1

Memory Dump is display of memory contents and address in hexadecimal on screen or printed on paper. It is powerful fault-tracing tool for expert programmers.

Hexadecimal are used in HTML to represent colour codes (RGB Model). For example: # ff0000 for bright red and #980000 for darker red.

MAC Addresses are unique number of NIC (Wi-Fi, Bluetooth. or wired connection i.e. Ethernet). They are 48 bit long, but converted into 12 hexadecimal digits (in 6 pairs) making them short and easier to understand. For 00-1C-2A-FF-01. 1st 3 pairs represent manufacturer while the other represent serial number of product.

UAA (Universally Administered MAC Address) are most common. These are the MAC addresses set by manufacturer

LAA (Locally Administered MAC Addresses) are changed locally to bypass firewall, or to assign MAC address of specific format.

URL encoding: Web addresses can be written using hexadecimal rather than denary.

Hexadecimal codes are preceded by a % sign. For example, the word “**www.ruknuddin.com**” is written as: %72%75%6B%6E%75%64%64%69%6E

Machine code and Assembly code are examples of low-level languages and are used by software developers when producing, for example, computer games. They look difficult but they have many advantages at the development stage of software writing (especially when trying to locate errors in the code). Using hexadecimal makes it much easier, faster and less error prone to write code compared to binary.

Character: Any text, number or symbol.

Compression: The method of reducing file size.

Lossy Compression: The file is reduced in size for transmission and storage; by permanently removing some redundant information from the file

Lossless Compression: The file is reduced in size for transmission and storage; it is then put back together again later producing a file identical to the original

MP3: File compression system for music which does not noticeably affect the quality of the sound. This is done using file compression algorithms which use **PERCEPTUAL MUSIC SHAPING**; this

essentially removes sounds that the human ear can't hear properly and background noise.

JPEG: File compression format designed to make photo files smaller in size for storage and for transmission.

MIDI: Standard adopted by the electronic music industry for controlling devices such as synthesisers and sound cards

MP4: MPEG-4 (MP4) format allows the storage of multimedia files rather than just sound. Music, videos, photos and animation can all be stored in the MP4 format. Videos, for example, could be streamed over the internet using the MP4 format.

Algorithm: step-by-step set of instruction to solve a problem.

Register: Immediate access store in the processor. It can store small piece of data.

Some of the number systems, those are studied in A Level Computer Science are:

- i) Denary (Decimal) number system
- ii) Binary number system
- iii) Hexadecimal number system

Denary (Decimal) Number System:-

“The number system which is based on 10 characters from 0 to 9 is called denary (decimal) system.”

It is the most common number system. The digits of decimal system are 0, 1, 2, 3, 4, 5, 6, 7, 8, and 9. The value of each digit in a figure depends upon its weight. The weights are based on power of 10.

Binary Number System:

In computer data is stored in the form of electric charge ON and OFF, represented by 1s and 0s. These “1’s” and “0’s” are called **bit** (being a contraction of **B**inary **digiT**), and 8 bits make a byte to represent a single character.

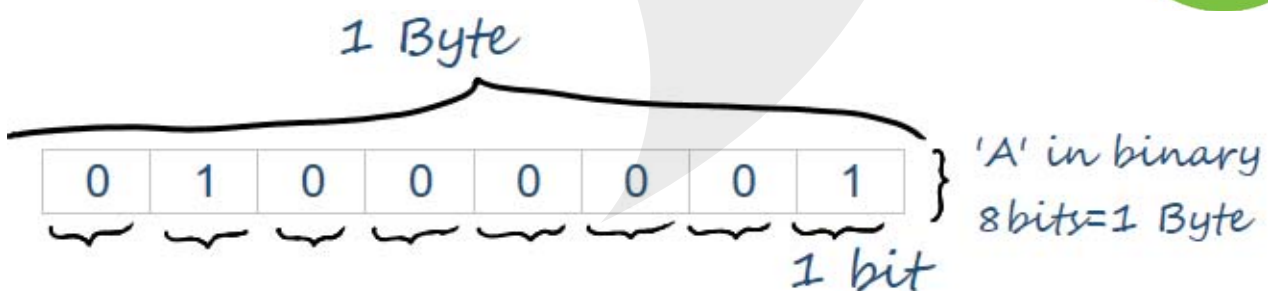

Binary numbers are fundamental to the way that all modern computers work. They are used to represent any data stored within a computer system.

1.1.2 Hexadecimal Number System:-

“The number system which is based on 16 characters from 0 to 9 and A, B, C, D, E & F is called Hexadecimal system.”

Benefits of Hexadecimal Numbers:

- Easier to convert long binary numbers into hexadecimals than into denary.
- Easier to read and understand
- Make it less prone to error



Uses of Hexadecimal System:

Uses of Hexadecimal in HTML:

Hyper Text Mark-up Language is used to develop Websites. In HTML a colour is specified according to the intensity of its Red, Green and Blue (RGB) components, each represented by eight bits. Thus, there are 24 bits used to specify a web colour, and 16,777,216 colours that may be so specified. It's easier for the human programmer to represent a 24-bit integer, often used for 32-bit colour values, as #FF0099 instead of 111111110000000010011001

BINARY (BITS)					HEX	
1	1	1	1	=	F	RR
1	1	1	1	=	F	
0	0	0	0	=	0	GG
0	0	0	0	=	0	
1	0	0	1	=	9	BB
1	0	0	0	=	8	
111111110000000010011001					FF0099	

HTML TAG Name

- RED (RED)
- GREEN (GREEN) LIME
- BLUE (BLUE)
- YELLOW (YELLOW)
- MAGENTA (MAGENTA) FUCHSIA
- CYAN (CYAN) AQUA

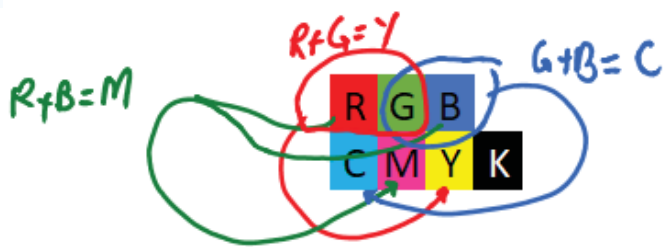
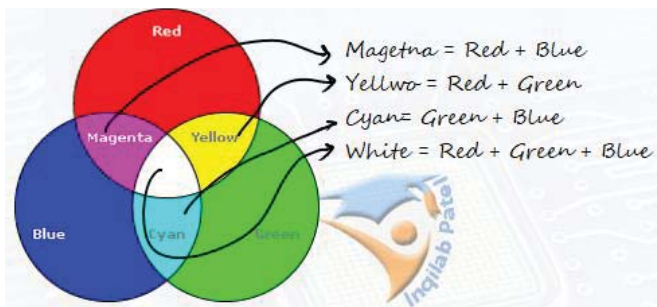

Uses of Hexadecimal in MAC Address:

MAC address is unique identification number of NIC (network interface card). It is 48 bits long, so 281 billion MAC addresses can be assigned computers.

MAC addresses are 48 bit long so they are very difficult to read, write and understand for example 0000 0000 0001 1100 1011 0011 0100 1111 0010 0101. To make them shorter and easy to understand they are shown in 12 hexadecimal digits in 6 groups, like 00 – 1C – B3 – 4F – 25 – FE. First 6 numbers (i.e. 00-1C-B3) are manufacturer identity while last 6 numbers (i.e. 4F-25-FE) are serial number of NIC.

There are two types of MAC address:

UAA (Universally administered MAC address) are the most common MAC address set by manufacturers. These are not changed.

LAA(Locally administered MAC address): These are changed locally, but they must be unique.

There are a few reasons why the MAC address needs to be changed using LAA:

- Certain software used on mainframe systems needs all the MAC addresses of devices to fall into a strict format; because of this, it may be necessary to change the MAC address of some devices to ensure they follow the correct format.
- It may be necessary to bypass a MAC address filter on a router or a firewall; only 24 MAC addresses with a certain format are allowed through, otherwise the devices will be blocked.
- To get past certain types of network restrictions it may be necessary to emulate unrestricted MAC addresses; hence it may require the MAC address to be changed on certain devices connected to the network.

Uses of Hexadecimal in Debugging:

Debugging allows programmers to detect, diagnose, and eliminate errors in a program. The source debugger uses the hexadecimal values of the characters. Hex is often used in error messages. The hex number refers to the memory location of the error. This helps programmers to find and then fix problems.

Memory Dump

Contents of memory are in binary numbers. Binary numbers are long and difficult to understand.

Memory dump is a hexadecimal view (on screen or paper) of computer data, from RAM or from a file or storage device. As memory dump uses hexadecimal number to show memory contents, it become a powerful fault tracing tool but requires expertise in computer architecture.

```
0000000 0000 0001 0001 1010 0010 0001 0004 0128
0000010 0000 0016 0000 0028 0000 0010 0000 0020
0000020 0000 0001 0004 0000 0000 0000 0000 0000
0000030 0000 0000 0000 0010 0000 0000 0000 0204
0000040 0004 8384 0084 c7c8 00c8 4748 0048 e8e9
0000050 00e9 6a69 0069 a8a9 00a9 2828 0028 fdfc
0000060 00fc 1819 0019 9898 0098 d9d8 00d8 5857
0000070 0057 7b7a 007a bab9 00b9 3a3c 003c 8888
0000080 8888 8888 8888 8888 288e be88 8888 8888
0000090 3b83 5788 8888 8888 7667 778e 8828 8888
00000a0 d61f 7abd 8818 8888 467c 585f 8814 8188
00000b0 8b06 e8f7 88aa 8388 8b3b 88f3 88bd e988
00000c0 8a18 880c e841 c988 b328 6871 688e 958b
00000d0 a948 5862 588a 7e81 3788 1ab4 5a84 3e8c
00000e0 3d86 dcb8 5cbb 8888 8888 8888 8888
00000f0 8888 8888 8888 8888 8888 8888 8888 0000
0000100 0000 0000 0000 0000 0000 0000 0000 0000
*
0000130 0000 0000 0000 0000 0000 0000 0000 0000
000013e
```

Uses of Hexadecimal in Assembly Language:

Machine codes are written in binary language which is very long and difficult to understand.

Hexadecimal numbers are easier, faster and less error prone to write code.

In assembly language codes are written in hexadecimal. This can have many advantages to program developers or when carrying out troubleshooting.

For example:

LDD A750 (assemble language)

A5E4 FFA4 (machine code using hexadecimal values)

1010 0101 1110 0100 1111 1111 1010 0100 (machine code using binary)

Memory Size Measurement

It should be pointed out here that there is some confusion in the naming of memory sizes.

There are two different methods:

- Denary Prefix System** used in SI Units. It is base 10 system. In this system $10^3 = 1000$ i.e. Kilo
- Binary Prefix System** used in IEC Units (**International Elctrro-Technical Commission**). It is a base 2 system. In this system $2^{10}=1024$ i.e. kibi
- 0 or 1 = 1 bit
- 4 bits = 1 nibble
- 8 bits = 2 nibbles = 1 byte

SI Units	IEC units
1 kilobyte = $10^3= 1000$ byte	1 kibibyte (1 KiB) = $2^{10}= 1024$ bytes
1 megabyte = $10^6=1000000$ bytes	1 mebibyte (1 MiB) = $2^{20}= 1048576$ bytes
1 gigabyte = $10^9=1000000000$ bytes	1 gibibyte (1 GiB) = $2^{30}= 1073741824$ bytes
1 terabyte = $10^{12}=1000000000000$ bytes and so on.	1 tebibyte (1 TiB) = $2^{40}= 1099511627776$ bytes and so on

Representation of Text and Numbers in Computer

Text and numbers can be represented in computer as patterns of binary digits. To represent each character (letter, digit or symbol) a character set is used. Character set is a set of characters can be understood by computer.

ASCII and Unicode are important character sets that are used as standard.

ASCII (American Standard Code for Information Interchange)

The ASCII character set is a 7-bit set of codes that allows 128 different characters. That is enough for every upper-case letter, lower-case letter, digit and punctuation mark on most keyboards. ASCII is only used for the English language.

Extended ASCII

Extended ASCII code is an 8-bit character set that represents 256 different characters, making it possible to use characters such as é or ©. Extended ASCII is useful for European languages.

Unicode

Unicode uses between 8 and 32 bits per character, so it can represent any characters from languages from all around the world. It is commonly used across the internet. As it is larger than ASCII, it might take up more storage space when saving documents.

Global companies, like Facebook and Google, would not use the ASCII character set because their users communicate in many different languages.

How text is encoded in computer

Each character in text has a unique binary code in ASCII, Extended ASCII and Unicode character set. To encode a text each character is replaced with the binary value given in ASCII/Extended/Unicode and stored in sequence.

Representation of Sound Files

Sampling: A sound wave is broken down into smaller pieces at a regular interval of time. These smaller pieces are known as **Sample** and this process is known as **Sampling**. In sampling amplitude of sound wave is taken at different intervals of time.

Sampling resolution – number of bits used to represent sound amplitude (also known as **bit depth**).

Sampling rate – number of sound samples taken per second.

Sound is a vibration that propagates as an acoustic wave, through a transmission medium such as a gas, liquid or solid.

Sound waves are longitudinal as they consist of alternating compressions and rarefactions, or regions of high pressure and low pressure, moving at a certain speed. The longitudinal sound waves are converted into transverse waves.

How to capture sound:

To record a sound microphone is used.

Microphone has a diaphragm. Diaphragm is attached with a moveable coil. Inside this movable coil there is fixed magnet.

When sound waves strike diaphragm, causes vibration in it and the movable coil starts moving to and fro around fixed magnet. This movement generates electrical signals. And in this way sound is captured.

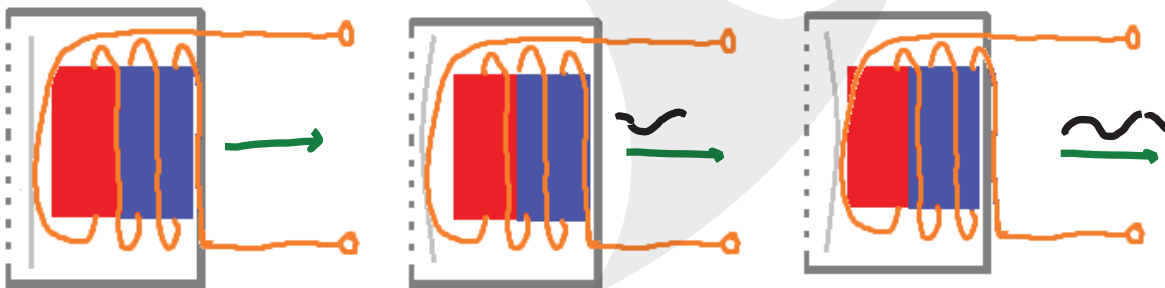

Conversion of Analogue Sound into Digital Format:

Sound waves are analogue values, these analogue values are converted into digital values to manipulate and to store in computer.

ADC (Analogue to Digital Converter) is used to convert analogue sound waves into digital values.

This conversion is done in following steps.

- Firstly, a filter removes non-audible sound waves. Humans can hear **sounds** in a **frequency range** from about 20 Hz to 20 kHz.
- Then sound waves are sampled at a given time rate (Sound waves are broken down thousands of smaller parts (samples) per second.)

- c) The height/amplitude of each sound wave is determined.
- d) Approximation is used when necessary.
- e) At last sound wave values are stored in binary digits, depending upon number of bits per sample.

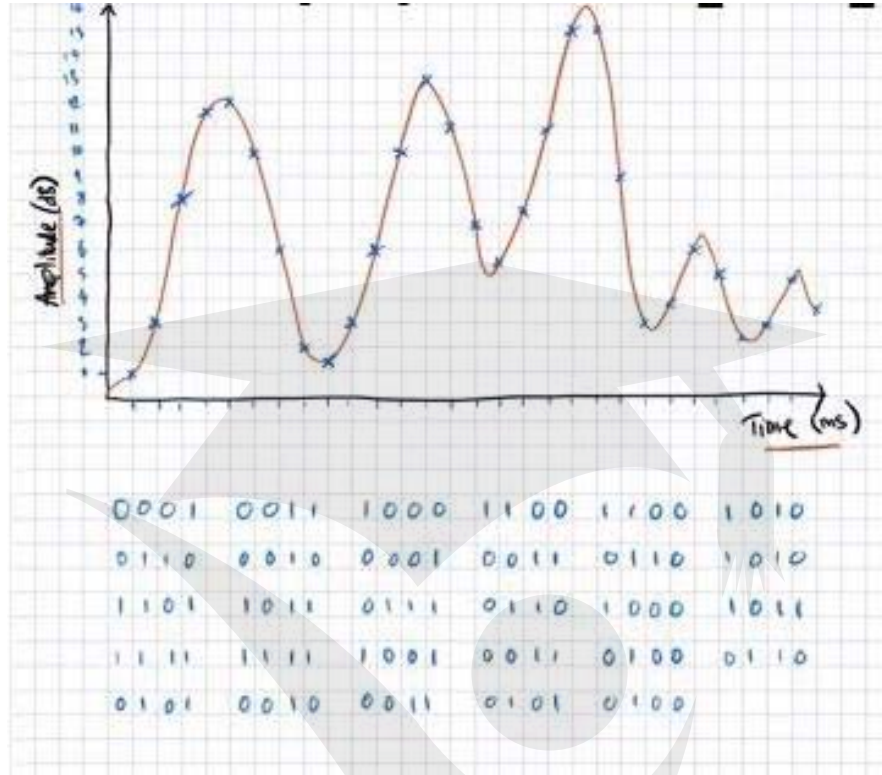

Digital audio quality

Factors that affect the quality of digital audio include:

- a) **Sample rate** - The **sample rate** is how many samples, or measurements, of the sound are taken each second. The more samples that are taken, the more detail about where the waves rise and fall is recorded and the higher the quality of the audio. Also, the shape of the sound wave is captured more accurately. Each sample represents the amplitude of the digital signal at a specific point in time.
- b) **Bit depth/Sampling Resolution** Bit depth is the number of bits available for each sample. The higher the bit depth, the higher the quality of the audio. Bit depth is usually 16 bits on a CD and 24 bits on a DVD. A bit depth of 16 has a resolution of 65,536 possible values (ranging from 0 to 65,535), and a bit depth of 24 has over 16 million possible values (ranging from 0 to 16,777,216).

Benefits of Higher Bit Depth:

The higher the bit depth, the higher the quality of the audio.

Allows for larger dynamic ranges (dynamic range is approximately six times the bit depth).

More accurate representation/crisper sound quality.

Increase in bit depth decreases the quantisation error.

Drawback of Higher Bit Depth:

Increasing bit depth also increases files size.

More disc and memory space is required.

Data will be transmitted slowly

Greater processing power will be required.

- c) **Bit rate** - The bit rate of a file tells us how many bits of data are processed every second. Bit rates are usually measured in **kilobits per second (kbps)**.

A common audio **sample rate** for music is **44,100 samples per second**. The unit for the sample rate is hertz (Hz). 44,100 samples per second is 44,100 hertz or 44.1 kilohertz (kHz).

Telephone networks and VOIP services can use a sample rate as low as 8 kHz. This uses less data to represent the audio. At 8 kHz, the human voice can still be heard clearly - but music at this sample rate would sound low quality.

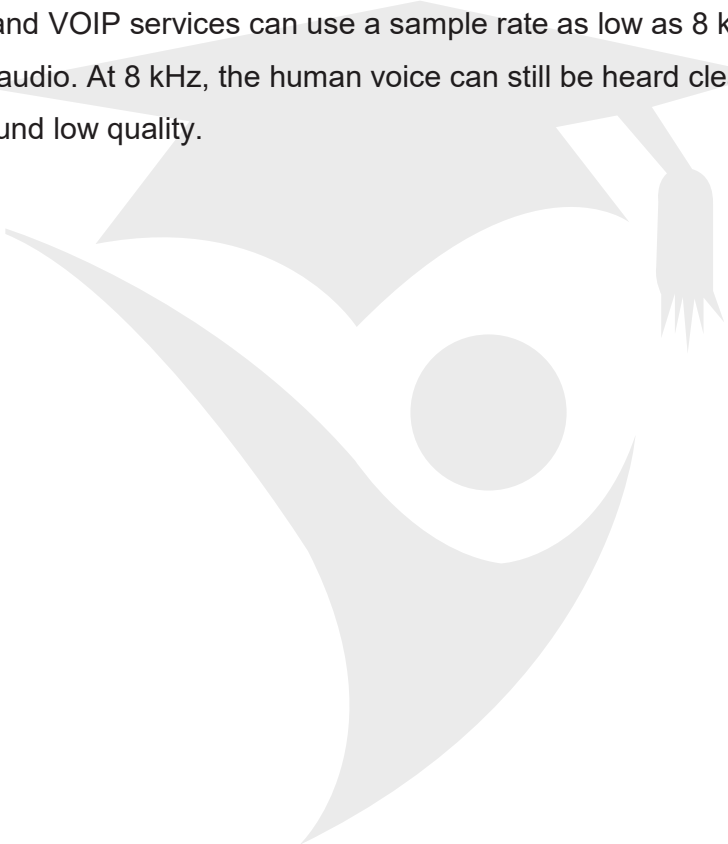

MIDI

Pronounced *middy*, an acronym for *musical instrument digital interface*, a standard adopted by the electronic music industry for controlling devices, such as synthesizers and sound cards, which emit music.



A MIDI file consists of a list of commands that instruct a device like an electronic organ, how to produce a particular sound or musical note.

Examples of MIDI commands include:

- note on/off: this indicates that a key has been pressed/released to produce/stop producing a musical note
- key pressure: this indicates how hard the key has been pressed (this could indicate loudness of the music note or whether any vibrato has been used, and so on).

The whole piece of music will have been stored as a series of commands but no actual musical notes. Their size, compared with an MP3 file, is considerably smaller. MIDI is essentially a communications protocol that allows electronic musical instruments to interact with each other.

The MIDI protocol uses 8-bit serial transmission with one start bit and one stop bit, and is therefore asynchronous.

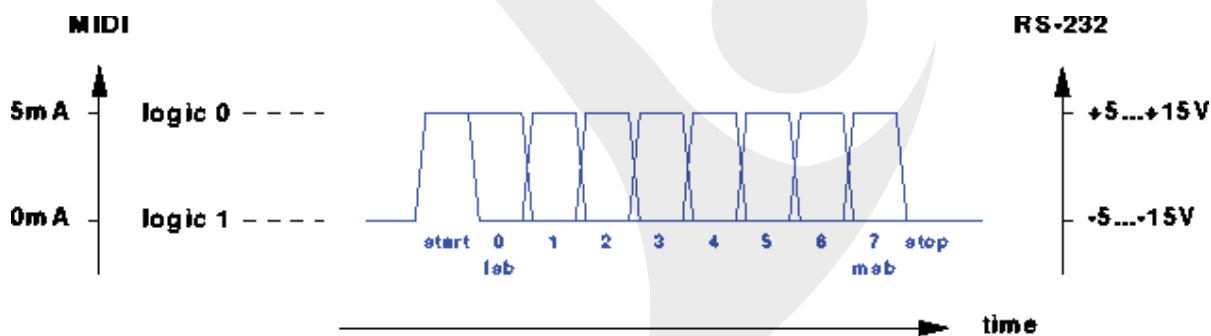

MIDI is essentially a communications protocol that allows electronic musical instruments to interact with each other.

Two additional bytes are required, a **PITCH BYTE** for note to play, and a **VELOCITY BYTE** for **loudness**. However, to play back through an instrument such as a guitar would need the use of **SEQUENCER SOFTWARE**.

MP3 (Moving Pictures Expert Group Audio Layer 3)

This has become the standard for distributing digital music files on the internet. It uses lossy compression to reduce file sizes to about a tenth of the original.

The compression algorithm is intended to remove sounds that are generally beyond the limits of most people's hearing and does not noticeably affect the quality of sound.

When using MP3 format, the size of the music track will be reduced by a factor of 10 (i.e. the size is reduced by 90% and remaining file size is only 10% of original size). This is done using file compression algorithms which use **PERCEPTUAL MUSIC SHAPING**; this essentially removes

For example, an 50 megabyte music CD can be reduced to 5 megabytes.
 $50 \text{ MB} \times 90/100 = 45 \text{ MB}$ reduced. $50 \text{ MB} \times 10/100 = 5 \text{ MB}$ new file size.

sounds that the human ear can't hear properly.

The quality of MP3 files depends on the **BIT RATE** – this is the number of bits per second used when creating the file. Bit rates are roughly between 80 and 320 kilobits per second; usually 200 or higher gives a sound quality close to a normal CD.

MPEG-4 (MP4) files are slightly different to MP3 files. This format allows the storage of multimedia files rather than just sound. Music, videos, photos and animation can all be stored in the MP4 format. Videos, for example, could be streamed over the internet using the MP4 format without losing any real discernible quality.

Bitmap Images

Bit-map image – system that uses pixels to make up an image.

Pixel – smallest picture element that makes up an image.

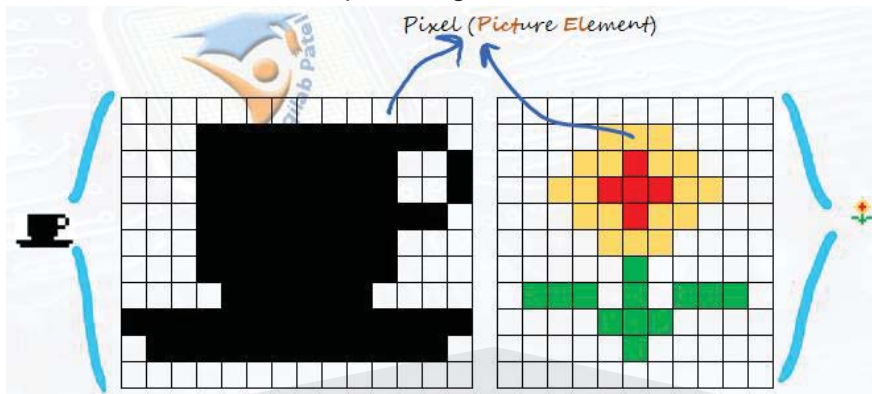

Bit depth – number of bits used to represent the smallest unit in, for example, a sound or image file – the larger the bit depth, the better the quality of the sound or colour image.

Colour depth – number of colours available in a pixel, e.g. 8 bit depth has colour depth of 256 ($2^8 = 256$).

Bit Depth	Colour Depth Available colours	Available Colours
1-bit	$2^1 = 2$	Monochrome (Black & White)
2-bit	$2^2 = 4$	Grey Scale
3-bit	$2^3 = 8$	RGB 8 Colours
7-bit	$2^7 = 128$	128 Colours
8-bit= 1 byte	$2^8 = 256$	256 Colour
24-bit= 3 byte	$2^{24} = 16,777,216$	True colours 16,777,216 Colours

Image resolution – number of pixels that make up an image, for example, an image could contain 4096×3192 pixels (12 738 656 pixels in total).

Screen resolution – number of horizontal and vertical pixels that make up a screen display. If the screen resolution is smaller than the image resolution, the whole image cannot be shown on the screen, or the original image will become lower quality.

Resolution – number of pixels per column and per row on a monitor or television screen.

Pixel density – number of pixels per square centimetre.

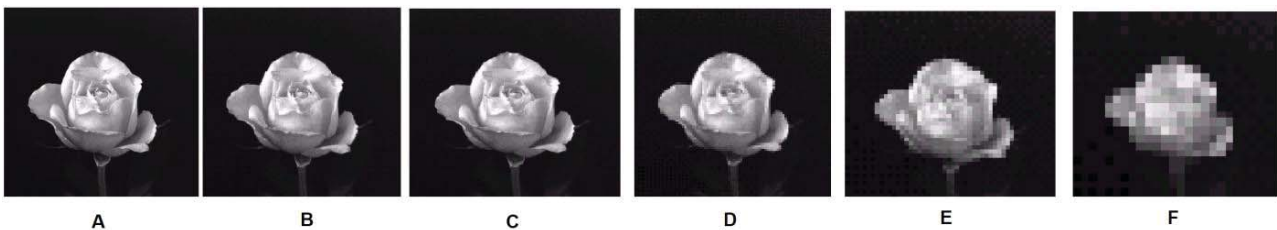

Vector graphics – images that use 2D points to describe lines and curves and their properties that are grouped to form geometric shapes.

How images are stored in computer:

The images are stored in computer as bitmaps

Each image is made up of tiny elements known as **Pixel (Picture Element)**

Each pixel is of a single colour. The number of available colours in a pixel is known as **Colour Depth**.

The Colour depth of the image is determined by **Bit Depth** i.e. number of bits per pixel

The image quality is also determined by **Pixel Density** i.e. number of pixels per inch.

The total number of pixels in an image is known as **Image Resolution**.

The values of each pixel of the image is stored in binary numbers.

JPG or JPEG (Joint Photographic Experts Group)

PEG is the file compression format designed to make photo files smaller in size for storage and for transmission. It uses lossy compression and compresses a file between factor of 5 to 15.

Image File Size Calculation



To calculate image file size, firstly number of pixels found out then these are multiplied to find total number of pixels in an image that gives, image resolution.

For example 2000 pixels wide and 2000 pixels high image will have $2000 \times 2000 = 4,000,000$ pixels. This is often referred to as a 4-megapixel image.



Uncompressed raw image

Then Image resolution is multiplied by bit depth.

Black & White image Bit Depth=1	Grey Scale Bit Depth=2	8-Colour Bit Depth= 3	True Colour Bit Depth=24
Image Size = 4,000,000 x 1 bit = 4,000,000 bit = 4,000,000 / 8 Byte = 500,000 Bytes = 500 KB	Image Size = 4,000,000 x 2 bit = 8,000,000 bit = 8,000,000 / 8 Byte = 1,000,000 Bytes = 1 MB	Image Size = 4,000,000 x 3 bit = 12,000,000 bit = 12,000,000 / 8 Byte = 1,500,000 Bytes = 1.5 MB	Image Size = 4,000,000 x 24 bit = 4,000,000 x 3 Byte = 12,000,000 Byte = 12 MB
Image Size = 500 KB	Image Size = 1 MB	Image Size = 1.5 MB	Image Size = 12MB

File Compression

Compression is a useful tool for reducing file sizes. When images, sounds or videos are compressed, data is removed to reduce the file size.

Advantage of File Compression

- a) Compressed file occupies lesser storage space
- b) Compressed file occupies lesser space in memory
- c) File can be uploaded and download quickly
- d) Lesser internet data is used in transmission of compressed file.

This is very helpful when streaming and downloading files.

Streamed music and downloadable files, such as MP3s, are usually between 128 kbps and 320 kbps - much lower than the 1,411 kbps of an uncompressed file.

Videos are also compressed when they are streamed over a network. Streaming HD video requires a high-speed internet connection. Without it, the user would experience buffering and regular drops in quality. HD video is usually around 3 mbps. SD is around 1,500 kbps.

Lossy and lossless compression

Compression can be lossy or lossless.

Lossless compression means that as the file size is compressed but data is restored back to its original state on uncompressing. Run Length Encoding is a method of lossless file compression. Lossless compression is mostly used for documents and software, sometime images and audio are also compressed using lossless compression.

Lossless compression can compress up-to 50%

Lossy compression permanently removes data. For example, an image file compressed to **jpeg** using factor of 5 to 15 while an audio WAV file compressed to an **MP3** (90% reduction in file size). Lossy file compression is mostly used for images, audio and video files.

Text file compression

Text and numbers are usually stored in an ASCII format. Text files are also compressed. Lossless compression method is used for text and numbers.

Algorithm 1:

These use complex algorithms that work on redundancy or repeated sections of words (e.g. OU in yOUr, cOUntry or mOUntain).

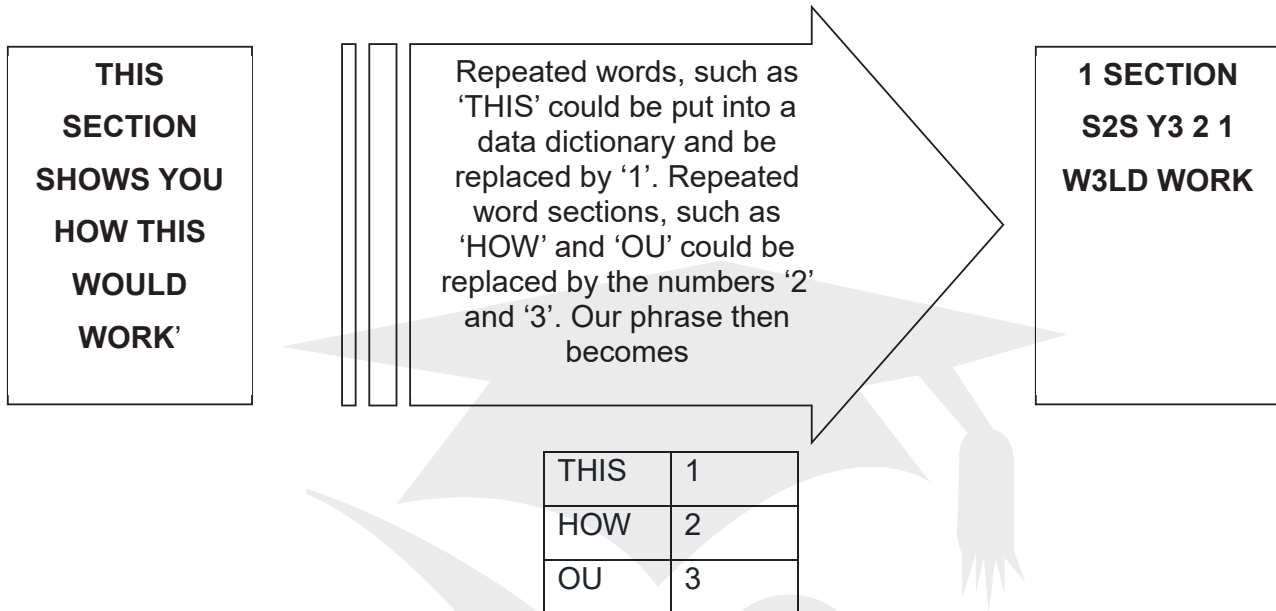

Text compression typically works by finding similar strings within a **text file**, and replacing those strings with a temporary binary representation to make the overall **file** size smaller. Computers can compress text by finding repeated sequences and replacing them with shorter representations, a character that isn't part of the original text.

For example a quote having 84 characters "Think left and think right and think low and think high. Oh, the thinks you can think up if only you try!"

The computer also needs to store the table of replacements that it made, so that it can reconstruct the original.

Replacement	original
\$	think
&	and
#	you

The repeated words replaced with the character and the compressed file has 50 characters. The compressed file is "\$ left & \$ right & \$ low & \$ high. Oh, the \$s # can \$ up if only # try!"

Text is compressed using Run Length Encoding method also.

Algorithm 2: Run length encoding (RLE) on text data

One of the simplest examples of compression is **RLE**.

RLE is a basic form of data compression that converts consecutive identical values into a code consisting of the character and the number marking the length of the run.

The more similar values there are, the more values can be compressed.

The sequence of data is stored as count and a single value.

For example to compress a text string "aaaabbbbccccccddddd" as "4a4b7c5d"

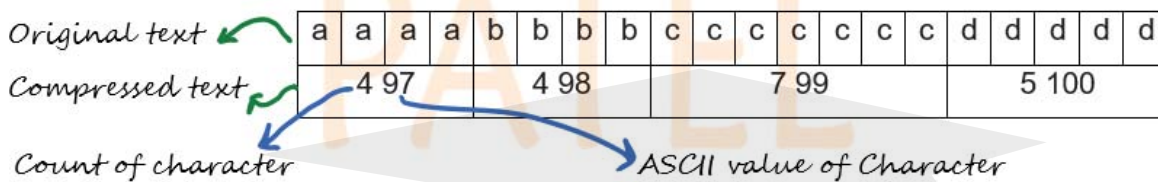
**Image File Compression**

Images are all around us, from application icons to animated GIFs to photos. Image files can take up a lot of space, so computers employ a range of algorithms to compress image files.

Lossy File Compression for Images

For lossy file compression of image file following steps are taken:

- A lossy file compression algorithm is used
- Bit Depth** (bits per pixel) is reduced resulting in reduction in colour depth (number of available colour) as well as file size (lesser number of bits lesser file size)
- Pixel density** (pixel per inch) is decreased resulting decrease in image resolution it too reduce file size (lesser pixel lesser bits means lesser file size).
- Reducing bit depth and pixel density reduces the file size but the removed data cannot be put back so original image cannot be recreated.

Lossless File Compression of Images

One of the simplest examples of lossless compression is **RLE**. To perform lossless compression of image following steps are taken:

- A lossless file compression algorithm RLE is used
- Consecutive pattern on images are identified.
- Consecutive identical pattern values converted into a code consisting of the image pattern and the number marking the length of the run.
- The more similar values there are, the more values can be compressed.
- The sequence of data is stored as a single value and count.

For example a Here's a simple image, a 16x11 black cup saucer icon with white background.



In run-length encoding, the computer replaces each row with numbers that say how many consecutive pixels are the same color, For example, 4 white pixels, 10 black pixels, and then 2 white pixels:

1111 0000 0000 0011 or WWWW BBBB BBBB BBWW

This would be represented after Run Length Encoding as follows:4 1 10 0 2 1 or 4W 10B 2W

Audio File Compression

Lossy File Compression of Audio using MP3:

This has become the standard for distributing digital music files on the internet. To perform lossy file compression on audio file following steps are take:

- a) Lossy file compression algorithm is used
- b) **Perceptual Music Shaping algorithm** is the lossy file compression for audio file
- c) It removes the background noise.
- d) It removes sounds that are generally beyond the limits of most people's hearing and does not noticeably affect the quality of sound.
- e) When using MP3 format, the size of the music track will be reduced by a factor of 10 (i.e. the size is reduced by 90% and remaining file size is only 10% of original size).
- f) The quality of MP3 files depends on the **BIT RATE** – this is the number of bits per second used when creating the file. Bit rates are roughly between 80 and 320 kilobits per second; usually 200 or higher gives a sound quality close to a normal CD.

For example, an 50 megabyte music CD can be reduced to 5 megabytes.
 $50 \text{ MB} \times 90/100 = 45 \text{ MB}$ reduced. $50 \text{ MB} \times 10/100 = 5 \text{ MB}$ new file size.

Lossless File Compression of Audio File

For lossless file compression of audio file following steps are taken:

- j) A lossless file compression algorithm RLE is used
- k) Consecutive sound patterns are identified.
- l) Consecutive identical sound pattern values are converted into a code consisting of the sound pattern and the number marking the length of the run.
- m) The more similar values there are, the more values can be compressed.
- n) The sequence of data is stored as a single value and count.

Video File Compression

- A compression algorithm is used
- Redundant data is removed
- Reduce colour depth
- Reduce image resolution
- Reduce sample rate
- Reduce sample resolution
- Reduce frame rate
- Use perceptual music shaping
- Data is **permanently** removed

Topical Past Paper Questions

18a Summer 21 P11

1 Benedict has a computer that is assigned an Internet Protocol (IP) address. The IP address is:

198.167.214.0

The IP address is represented as denary values.

(a) Convert the denary values 167 and 214 from the IP address to 8-bit binary.

167							
214							

Working space

..... [2]

(b) Benedict's computer is also assigned a Media Access Control (MAC) address.

(i) Identify one similarity between an IP address and a MAC address.

..... [1]

(ii) Identify two differences between an IP address and a MAC address.

Difference 1

Difference 2

[2]

Question	Answer	Marks																
1(a)	One mark per each correct register. <table border="1" style="margin: 5px 0;"> <tr> <td>1</td><td>0</td><td>1</td><td>0</td><td>0</td><td>1</td><td>1</td><td>1</td> </tr> </table> <table border="1" style="margin: 5px 0;"> <tr> <td>1</td><td>1</td><td>0</td><td>1</td><td>0</td><td>1</td><td>1</td><td>0</td> </tr> </table>	1	0	1	0	0	1	1	1	1	1	0	1	0	1	1	0	2
1	0	1	0	0	1	1	1											
1	1	0	1	0	1	1	0											
1(b)(i)	Any one from: <ul style="list-style-type: none"> – Both addresses can be used to identify a computer/device – Both are unique – Both can be represented as hexadecimal – Both addresses do not change if IP address is static 	1																
1(b)(ii)	Any two from: <ul style="list-style-type: none"> – An IP address is assigned by the network/router/ISP, A MAC address is assigned by the manufacturer – An IP address can be changed (if dynamic), MAC address cannot be changed – IP address has 4/8 groups of values, MAC address has 6 groups/pairs of values – IP address is 32-bit/128-bit, MAC address is 48-bit – IP address does not contain serial number/manufacturer number, MAC address does – IP(v4) address is denary and MAC address is hexadecimal 	2																

18b Summer 21 P12

1 A denary value can be converted into hexadecimal and binary.

[6]

(a) Complete the table to show the hexadecimal and 8-bit binary values of the given denary values.

Denary	Hexadecimal	8-bit binary
49		
123		
200		

Working space

.....

(b) Give two benefits, to users, of converting binary values to hexadecimal.

Benefit 1

.....

Benefit 2

.....

[2]

(c) Hexadecimal is used to represent Hypertext Markup Language (HTML) colour codes in computer science.

Identify three other ways that hexadecimal is used in computer science.

- 1
- 2
- 3 [3]

1(a)	<p>One mark per each correct binary value. One mark per each correct hex value.</p> <table border="1" data-bbox="295 667 837 907"> <thead> <tr> <th>Denary</th> <th>Hexadecimal</th> <th>8-bit binary</th> </tr> </thead> <tbody> <tr> <td>49</td> <td>31</td> <td>00110001</td> </tr> <tr> <td>123</td> <td>7B</td> <td>01111011</td> </tr> <tr> <td>200</td> <td>C8</td> <td>11001000</td> </tr> </tbody> </table>	Denary	Hexadecimal	8-bit binary	49	31	00110001	123	7B	01111011	200	C8	11001000	6
Denary	Hexadecimal	8-bit binary												
49	31	00110001												
123	7B	01111011												
200	C8	11001000												
1(b)	<p>Any two from:</p> <ul style="list-style-type: none"> - Easier/quicker to read/write/understand - Easier/quicker to identify errors/debug - Takes up less screen/display space - Less chance of making an error 	2												
1(c)	<p>Any three from:</p> <ul style="list-style-type: none"> - MAC address - URL - Assembly language - Error codes // error messages - IP addresses - Locations in memory - Memory dumps 	3												

18c Summer 21 P13

1 Greta has a computer that she uses for schoolwork and leisure.

(a) The computer has the Media Access Control (MAC) address:

00:A0:C9:14:C8:29

(i) Tick (✓) to show whether the MAC address is initially assigned to the computer by the network, the manufacturer or the user. [1]

	Tick (✓)
Network	
Manufacturer	
User	

(ii) The values in the MAC address are hexadecimal values.

Convert the three given hexadecimal values into 8-bit binary.

14 [3]
 A0
 C9

Working space

(iii) Convert the two given hexadecimal values into denary.

29 [2]
 C8

Working space

Answers:

- 1 (a) (i) Manufacturer
- 1 (a) (ii) 00010100
10100000
11001001
- 1 (a) (iii) 41
200

2 Jolene displays videos on her website. She uses lossy compression to reduce the file size of the videos.

(a) Describe how lossy compression reduces the file size of the videos.

.....

 [3]

(b) State two reasons why Jolene would use lossy rather than lossless compression for the videos.

Reason 1

 Reason 2 [2]

2(a)	Any three from: – A compression algorithm is used – Redundant data is removed – Reduce colour depth – Reduce image resolution – Reduce sample rate – Reduce sample resolution – Reduce frame rate – Use perceptual music shaping – Data is permanently removed	3
2(b)	Any two from: – Lossy decreases the file size more – Take up less storage space on webserver/users' computer – Quicker to upload/download – May not need to be high quality – Website will load faster for users – Less lag/buffering when watching – Takes up less bandwidth to download/upload – Uses less data allowance	2

Q 1) Summer 2015 P11

8 An alarm clock is controlled by a microprocessor. It uses the 24 hour clock. The hour is represented by an 8-bit register, **A**, and the number of minutes is represented by another 8-bit register, **B**.

(a) Identify what time is represented by the following two 8-bit registers.

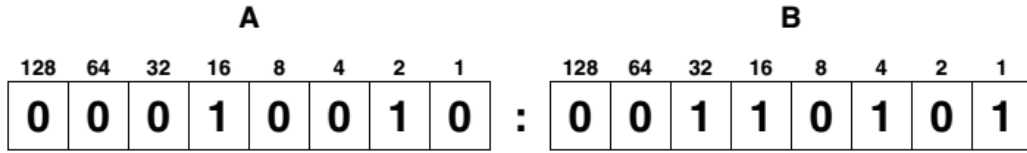

Hours Minutes [2]

(b) An alarm has been set for 07:30. Two 8-bit registers, **C** and **D**, are used to represent the hours and minutes of the alarm time.

Show how 07:30 would be represented by these two registers:

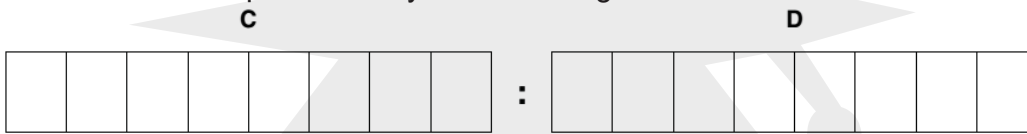

Hours Minutes [2]

(c) Describe how the microprocessor can determine when to sound the clock alarm.

.....

 [3]

9 Draw a line to connect each question to the correct answer. [5]

Question	Answer
What is the denary (base 10) equivalent to the hexadecimal digit E ?	8
If $1 \text{ GB} = 2^x$ then what is the value of X?	12
How many bits are there in one byte?	14
If the broadband data download rate is 40 megabits per second, how many seconds will it take to download a 60MB file?	19
What is the denary (base 10) value of the binary number 00100100?	30
What hexadecimal value is obtained when the two hexadecimal digits C and D are added together?	36

Examiner's Comments on Question 9

The full range of marks was awarded for this question. Many candidates gained full marks. The most common errors were miscalculations for 30, 19 and 12.

Q 2) Summer 2015 P12

10 Letters from the alphabet are represented in a computer by the following denary (base 10) values:

- a = 97
- g = 103
- i = 105
- l = 108
- n = 110

The word "ALIGN" is stored as: 97 108 105 103 110

(a) Convert each of the five values to binary. The first one has been done for you. [2]

Letter	Binary value							
a (97):	0	1	1	0	0	0	0	1
l(108):								
i (105):								
g (103):								
n (110):								

(b) An encryption system works by shifting the binary value for a letter one place to the left. "a" then becomes:

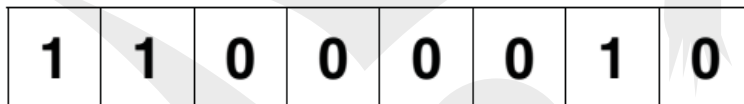

This binary value is then converted to hexadecimal; the hexadecimal value for "a" will be:

C 2

For the two letters "L" and "G", shift the binary values one place to the left and convert these values into hexadecimal: [4]

	hexadecimal									
L:	<table border="1" style="width: 100%; height: 20px;"> <tr><td></td><td></td><td></td><td></td><td></td><td></td><td></td><td></td></tr> </table>								
G:	<table border="1" style="width: 100%; height: 20px;"> <tr><td></td><td></td><td></td><td></td><td></td><td></td><td></td><td></td></tr> </table>								

Examiner's comments on Questions 10(a) and 10(b)

Many candidates showed some knowledge of binary conversion in part (a) and could correctly convert the values. Some candidates showed little knowledge and gave a random and incorrect response as a result.

In part (b) many candidates were able to correctly carry out the bit shift then convert the value to hex. Some candidates gained marks for a correct bit shift but were unable to demonstrate the knowledge to convert the values to hex so gained two marks.

Candidates were awarded follow through marks if they had calculated the values incorrectly in part (a) for both their bit shift and the hex conversion.

Q 3) Winter 2015 P12

2 Seven computer terms and seven descriptions are shown below.

Draw a line to link each computer term to its most appropriate description.

Interface	Reduction of file size by permanently removing some redundant information from the file
JPEG	File compression system for music which does not noticeably affect the quality of the sound
Lossless compression	Hardware component that allows the user to communicate with a computer or operating system
Lossy compression	The file is reduced in size for transmission and storage; it is then put back together again later producing a file identical to the original
MIDI	File compression format designed to make photo files smaller in size for storage and for transmission
MP3 format	Standard adopted by the electronic music industry for controlling devices such as synthesisers and sound cards

4 (a) (i) Convert the following **two** hexadecimal numbers into binary:

FA7
D3E

FA7	<input type="checkbox"/>	<input type="checkbox"/>	<input type="checkbox"/>	<input type="checkbox"/>	<input type="checkbox"/>	<input type="checkbox"/>	<input type="checkbox"/>	<input type="checkbox"/>	<input type="checkbox"/>	<input type="checkbox"/>	<input type="checkbox"/>	<input type="checkbox"/>
D3E	<input type="checkbox"/>	<input type="checkbox"/>	<input type="checkbox"/>	<input type="checkbox"/>	<input type="checkbox"/>	<input type="checkbox"/>	<input type="checkbox"/>	<input type="checkbox"/>	<input type="checkbox"/>	<input type="checkbox"/>	<input type="checkbox"/>	<input type="checkbox"/>

[4]

(ii) Now perform the AND (logic) operation on each corresponding pair of binary bits in the two numbers from **part (i)**.

<input type="checkbox"/>	<input type="checkbox"/>	<input type="checkbox"/>	<input type="checkbox"/>	<input type="checkbox"/>	<input type="checkbox"/>	<input type="checkbox"/>	<input type="checkbox"/>	<input type="checkbox"/>	<input type="checkbox"/>	<input type="checkbox"/>	<input type="checkbox"/>
--------------------------	--------------------------	--------------------------	--------------------------	--------------------------	--------------------------	--------------------------	--------------------------	--------------------------	--------------------------	--------------------------	--------------------------

[2]

(iii) Convert your answer in **part (ii)** into hexadecimal.

..... [2]

(b) (i) The following code shows HTML 'tag' pairs on either side of the text stating the colour that each creates.

```
<font color " # F F 0 0 0 0 " > RED </font>  
<font color " # 0 0 F F 0 0 " > GREEN </font>  
<font color " # 0 0 0 0 F F " > BLUE </font>  
<font color " # X " > YELLOW </font>  
<font color " # Y " > MAGENTA </font>  
<font color " # Z " > CYAN </font>
```

Yellow is a combination of red and green, magenta a combination of red and blue and cyan a combination of green and blue.

State what 6-digit hexadecimal values should replace X, Y and Z in the above code.

X
Y
Z [3]

(ii) Describe how other colours, such as a darker shade of blue, are created.

.....
.....
..... [2]

(c) 1A – 16 – C5 – 22 – FF – FF is an example of a MAC address.

(i) Identify what the first six and last six hexadecimal digits represent.

First six digits
.....
Last six digits
..... [2]

(ii) State why MAC addresses are used.

.....
..... [1]

Q 4) Winter 2015 P13

2 (b) The information from seven sensors is sent to an engine management system in the car. The status of each sensor is stored in an 8-bit register; a value of 1 indicates a fault condition

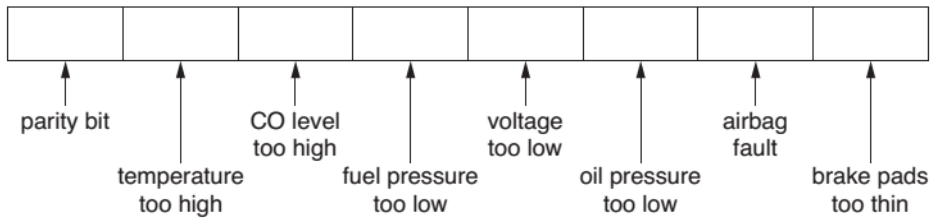

For example, a register showing **0 1 0 1 1 0 0 0** indicates:

- temperature too high
- fuel pressure too low
- voltage too low

(i) Identify the fault condition(s) that the following register indicates:



.....

 [2]

(ii) The system uses **odd** parity.

Write the correct parity bit in each register.



[2]

(iii) A car has a faulty airbag and the CO level is too high.

Write what should be contained in the 8-bit register.

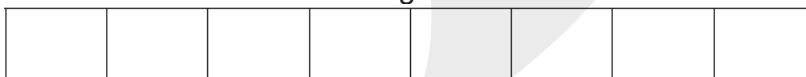

[2]

(iv) Give the hexadecimal value of the binary number shown in **part (iii)**.

.....
 [1]

9 MP3 file compression reduces the size of a music file by 90%.

(a) A music track is 80 MB in size.

Calculate the file size after compression.

.....

How many MP3 files of the size calculated above could be stored on an 800 MB CD?

..... [2]

(b) (i) Explain how MP3 files retain most of the original music quality.

.....
.....
.....
.....
..... [2]

(ii) State the type of file compression used in MP3 files.

..... [1]

(iii) Name another file compression format.

..... [1]

Q 5) Winter 2015 P11

2 (a) Convert the hexadecimal number **B5** into binary:

.....
.....

Convert the binary number **1 1 1 1 0 1 1 0** into hexadecimal:

..... [2]

(b) Give **two** examples where hexadecimal numbers are used in computer science.

1:
2: [2]

(c) State **two** benefits of using hexadecimal numbers in computer science.

1:
.....
2:
..... [2]

7 (a) Describe what is meant by lossy and lossless compression when applied to files.

Lossy:
.....
.....

Lossless:
.....
..... [2]

(b) Name and describe **one** type of file that uses lossy compression.

Name:
Description:
..... [2]

(c) A company advertises its backup memory device as having 500 GB of storage. A customer wishes to know how many 8 MB files could be stored on the device. The company claimed that up to 62 500 files (assuming each file is 8 MB) could be stored. The customer calculated that 64 000 files could be stored.

Explain the difference between these two storage values. Show any calculations you use in your explanation.

.....

.....

.....

.....

.....

..... [3]

10 Characters can be represented in a computer by a numerical code. The following list shows 16 characters with their numerical codes in denary:

- | | | | | |
|---------------------------------|---------|---------|---------|---------|
| a = 97 | d = 100 | h = 104 | m = 109 | t = 116 |
| b = 98 | e = 101 | i = 105 | o = 111 | u = 117 |
| c = 99 | g = 103 | k = 107 | r = 114 | w = 119 |
| . = 46 (code for the full stop) | | | | |

Web addresses can be written using hexadecimal rather than denary. Hexadecimal codes are preceded by a % sign. For example, the word "c a g e" is written as:

- | | | | | | |
|--------|-----|-----|-----|-----|------------------|
| either | 99 | 97 | 103 | 101 | (in denary) |
| or | %63 | %61 | %67 | %65 | (in hexadecimal) |

(a) Complete the conversion of the following web address into hexadecimal: [3]

w	w	W	.	C	i	e	.	o	r	g	.	u	K
%77	%77	%77											

b) Complete the web address from the given hexadecimal codes: [3]

%77	%77	%77	%2E	%72	%6F	%63	%6B	%69	%63	%74	%2E	%63	%6F	%6D
w	w	W												

Q 8) Winter 2016 P12

5 A computer uses an 8-bit register. The 8-bit register contains binary integers.

(a) Write the denary (base 10) value represented by:

128	64	32	16	8	4	2	1
0	1	1	1	0	0	0	0

..... [1]

(b) All the bits in the register are shifted **one** place to the **right** as shown below.

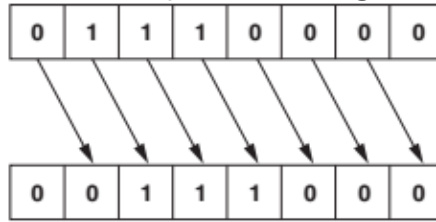

Write the denary number that is represented after this shift.

..... [1]

(c) State the effect the shift to the right had on the original denary number from **part (a)**.

..... [1]

(d) The original number in **part (a)** is shifted **three** places to the **right**.

(i) Show the new binary number:

[1]

--	--	--	--	--	--	--	--

(ii) Write the equivalent denary number.

..... [1]

(e) Describe the problems that could be caused if the original binary number in **part (a)** is shifted **five** places to the **right**.

..... [2]

Q 16) Summer 2018 P11

1 Jane answers an examination question about computers and data correctly.

Six different words or numbers have been removed from her answer.

Complete the sentences in Jane's answer, using the list given. Not all items in the list need to be used.

- 2
- 10
- 16
- analogue
- binary
- denary
- digital
- hexadecimal

As humans, we process data, but a computer cannot process this type of data. For a computer to be able to process data it needs to be converted to data.

As humans, we mostly use a number system; this is a base number system.

Computers use a number system; this is a base number system. [6]

2 Dheeraj identifies **three** hexadecimal numbers.

Write the **denary** number for each of the three hexadecimal numbers:

2A

101

21E

[3]

Q 17) Summer 2018 P12

1 Different units of data can be used to represent the size of a file, as it changes in size.

Fill in the missing units of data, using the list given:

[4]

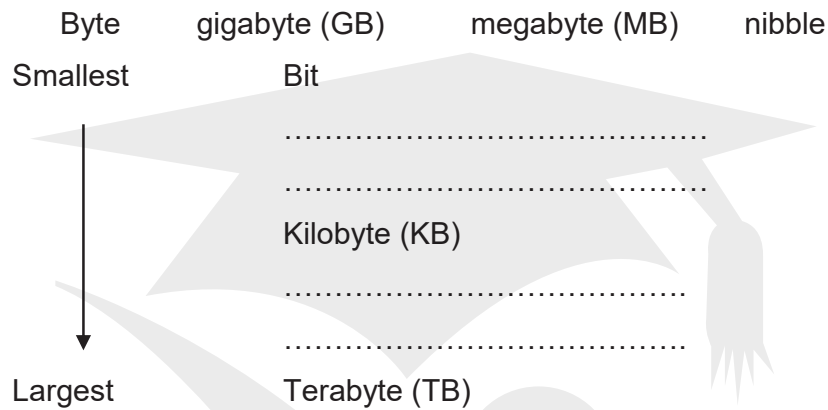

Q 21) Summer 2019 P11

1 Hexadecimal is used for MAC addresses.

Part of a MAC address is given:

97 – 5C – E1

Each pair of digits is stored as binary in an 8-bit register.

(a) Show what the binary register stores for each pair of the given digits.

[6]

97

--	--	--	--	--	--	--	--

5C

--	--	--	--	--	--	--	--

E1

--	--	--	--	--	--	--	--

(b) Explain what is meant by a MAC address.

.....

.....

.....

.....

.....

.....

.....

.....

.....

..... [4]

(c) Give **two** other examples where hexadecimal can be used. [2]

5 The following text is stored as a text file:

She sells sea shells on the seashore. The shells that she sells are sea shells I am sure.

Explain how lossless compression would compress this file.

.....
.....
.....
.....
.....
.....
.....
.....
.....
.....
.....

7 Annie writes a paragraph of text as an answer to an examination question about programming languages. Using the list given, complete Annie’s answer by inserting the correct **six** missing terms. Not all terms will be used.

- Assembly
- Converter
- Denary
- Hexadecimal
- High-level language
- Low-level language
- Machine Code
- Source Code
- Syntax
- Translator

The structure of language statements in a computer program is called the A programming language that uses natural language statements is called a When programs are written in this type of language they need a to convert them into A programming language that is written using mnemonic codes is called language. this is an example of a [6]

Q 21) Winter 2019 P13

1 (c) The library has a website that customers can use to search for a book.

(i) The website has a background colour with the hexadecimal colour code #F92A10The colour code is stored in two 12-bit binary registers. [6]

Show how the colour code would be stored in the registers.

F92

--	--	--	--	--	--	--	--	--	--	--	--

A10

--	--	--	--	--	--	--	--	--	--	--	--

(ii) Videos on the library website show customers which books the library will soon have in stock. The library wants the file size of a video to be as small as possible. Identify and describe a method the library could use to reduce the file size of a video as much as possible.

.....

.....

.....

.....

.....

.....

.....

.....

[4]

Q 22) Winter 2019 P12

1 Computer memory size is measured in multiples of bytes. Four statements about computer memory sizes are given in the table.

Tick (✓) to show if the statement is **True** or **False**.

[4]

Statement	True (✓)	False (✓)
25kB is larger than 100MB		
999MB is larger than 50GB		
3500kB is smaller than 2GB		
2350bytes is smaller than 2kB		

3 The data from a sensor must be converted from analogue to digital to be processed by a computer.

(a) State what is meant by analogue data.

.....

.....

[1]

(b) State what is meant by digital data.

.....

.....

[1]

4 An 8-bit binary register contains the value:

0	0	1	1	0	1	0	0
---	---	---	---	---	---	---	---

(a) Convert the binary value to denary.

.....

.....

[1]

(b) The contents of the register shifted one place to the right would give the result:

0	0	0	1	1	0	1	0
---	---	---	---	---	---	---	---

The contents of the register shown at the start of question 4 are shifted two places to the left.

Show the contents of the register after this shift has taken place.

[1]

--	--	--	--	--	--	--	--

(c) State the effect this shift has on the denary value in **part (a)**.

..... [1]

5 Audrey wants to send a sound file to Nico using email.

The file is too large to attach to an email so Audrey decides to compress the file.

She uses lossy compression to reduce the size of the sound file.

(a) Describe how lossy compression reduces the size of the sound file.

..... [4]

(b) Nico asks Audrey why she used lossy compression rather than lossless.

(i) State **one** advantage Audrey could give of using lossy rather than lossless to compress the sound file.

..... [1]

(ii) State **one** disadvantage Nico could give of using lossy rather than lossless to compress the sound file.

..... [1]

(c) Audrey sometimes records MIDI files.

(i) Explain what is meant by a MIDI file.

..... [4]

Q 25) Summer 20 P11

1 (c) All smartphones have a MAC address.

(i) State what is meant by the term MAC address.

..... [1]

(ii) Describe the structure of a MAC address.

.....

 [3]

Q 27) Winter 20 P13

3 (a) Four denary to 8-bit binary conversions are given.

Tick (✓) to show if each denary to 8-bit binary conversion is **Correct** or **Incorrect**. [4]

Denary	Binary Conversion	Correct (✓)	Incorrect (✓)
145	10010001		
179	10110101		
11	00010011		
100	01100010		

(b) Convert the **12-bit** binary number into hexadecimal.

1	1	0	0	0	1	0	0	0	0	0	0
---	---	---	---	---	---	---	---	---	---	---	---

..... [3]

Q 28) March 21 P12

1 (b) Give the largest denary value that can be stored in the 8-bit binary register.

..... [1]

(c) The hockey club wants to increase the number of people that can watch each match to 2000.

The 8-bit binary register may no longer be able to store the value.

Give the smallest number of bits that can be used to store the denary value 2000.

..... [1]

Working space

.....

Chapter 2

1.2 Communication and Internet Technologies

S No	Learning Outcome	To Read	Have Read	To Revise	Have Revised	Prepared
	1.2.1: Serial and parallel data transmission					
1	Show understanding of what is meant by transmission of data					
2	Distinguish between serial and parallel data transmission					
3	Distinguish between simplex, duplex and half-duplex data transmission					
4	Reasons for choosing serial or parallel data transmission					
5	Show understanding of the need to check for errors					
6	Explain how parity bits are used for error detection					
7	Show understanding of the use of serial and parallel data transmission, in Universal Serial Bus (USB) and Integrated Circuit (IC)					
	1.2.3: Internet principles of operation					
8	Show understanding of the role of the browser and Internet server					
9	What is meant by hypertext transfer protocol (http and https) and HTML					
10	Distinguish between HTML structure and presentation					
11	Show understanding of the concepts of MAC address, Internet Protocol (IP) address, Uniform Resource Locator (URL) and cookies					

Chapter at a glance:

A **network** is defined as a collection of computers and peripheral devices (such as printers) connected together.

Generally, a network over short distances is called a **local area network (LAN)** while those over great distances are **wide area networks (WAN)**.

Network adapters: These adapters (also called network interface cards or NICs) connect computers to a network so that they can communicate.

Network hubs and switches: Hubs and switches connect two or more computers to an Ethernet network.

Routers connect computers and networks to each other (for example, a router can connect your home network to the Internet).

Modem: Hardware device that converts signals from analogue to digital and vice versa; typically used to convert signals sent over the public service telephone network.

Bit is short of binary digit. It is the smallest unit of data in computer. It consists of a 0 or an 1.

Bit rate is the rate of transmitting data

A **web browser** is software which allows a user to display a web page on their computer screen. Web browsers interpret or translate the HTML code from websites and show the result of the translation.

Simplex data transmission is sending data in one direction only (i.e. from sender to receiver)

Example: data being sent from a computer to a printer.

Half-duplex data transmission is sending data in both directions but only one at a time (i.e. data can be sent from 'A' to 'B' or from 'B' to 'A' along the same line, but not at the same time).

Example: a walkie-talkie, fax machine.



Full-duplex data transmission is sending data in both directions simultaneously (i.e. data can be sent from 'A' to 'B' and from 'B' to 'A' along the same line, *both at the same time*). Example: a phone line.

Serial data transmission is when data is sent, *one bit at a time, over a single wire or channel*

Serial Transmission is transfer of data bit by bit using single wire (bits are sent one after the other in a single stream).

Parallel Transmission is transfer of data in groups of bits using multiple wires.

The **universal serial bus (USB)** is an asynchronous serial data transmission method. It has quickly become the standard method for transferring data between a computer and a number of devices.

Interference refers to disturbance that occurs in the signals when sending data that may corrupt it.

ISP (Internet Service Provider): Company that provides individual's access to the Internet and other services such as webhosting and emails

IP Address: Location of a given computer/device on a network; can be a static or dynamic value

URL (Uniform Resource Locator): The standard format for referring to a source on the Internet; also called Uniform Resource Indicator (URI); made up of:

- the protocol, e.g. http
- the domain name, e.g. ruknuddin.com
- the filename e.g. computer.html

HTML: Authoring language used to create documents on the World Wide Web; uses tags and attributes

HTML Structure refers to contents of web pages.

HTML Presentation is format of webpage.

Cascade Style Sheet CSS is used to define presentation for web pages, including the design and variations in display for different devices and screen sizes.

Web Server are the computers which hosts web sites.

Checksum technique used in data transmission to validate data by sending a block of data calculated from the contents of preceding blocks.

Parity Check technique used in data transmission to validate data by sending an additional bit determined by the contents of the preceding bits to make the total number of 1s odd or even.

Parity Block is an additional byte where the bits are computed from the preceding data bytes. The bytes are arranged in a grid and each parity byte bit is calculated from the bits in the column above.

Check digit is a validation technique that involves calculating an additional digit from the ones that precede it. Following two Methods are used to calculate check digit

Automatic Repeat Request (ARQ) is another method used to check whether data has been correctly transmitted.

It uses an **acknowledgement** (a message sent by the receiver indicating that data has been received correctly) and **timeout** (this is the time allowed to elapse before an acknowledgement is received).

If an acknowledgement isn't sent back to the sender before timeout occurs, then the message is automatically resent.

With **echo check**, when data is sent to another device, this data is sent back again to the sender. The sender compares the two sets of data to check if any errors occurred during the transmission process.

1.2.1 Data Transmission

Data transmission is communicating data among different parts of a computer or among different computers.

Generally, a network over short distances is called a **local area network (LAN)** while those over great distances are **wide area networks (WAN)**. Whether a network is a WAN or a LAN, it allows the computers to:

- communicate with one another
- share information centrally
- share copies of software
- give access to data and program files to multiple user

In a LAN there is the added benefit of being able to share hardware. For example, the office with 20 computers may only have one or two printers. Also, those printers may be of different types and used for different tasks.

Types of Communication (on the basis of direction)

Simplex data transmission is sending data in one direction only (i.e. from sender to receiver).

Example: Radio, TV. Data being sent from a computer to a printer, from keyboard to CPU etc.

Half-duplex data transmission is sending data in both directions but only one at a time (i.e. data can be sent from 'A' to 'B' or from 'B' to 'A' along the same line, but not at the same time).

Example: a walkie-talkie, fax machine, reading or burning data on CDs or DVDs, both but not at the same time.

Full-duplex data transmission is sending data in both directions simultaneously (i.e. data can be sent from 'A' to 'B' and from 'B' to 'A' along the same line, both at the same time).

Example: a phone line, reading and writing data on HDD.

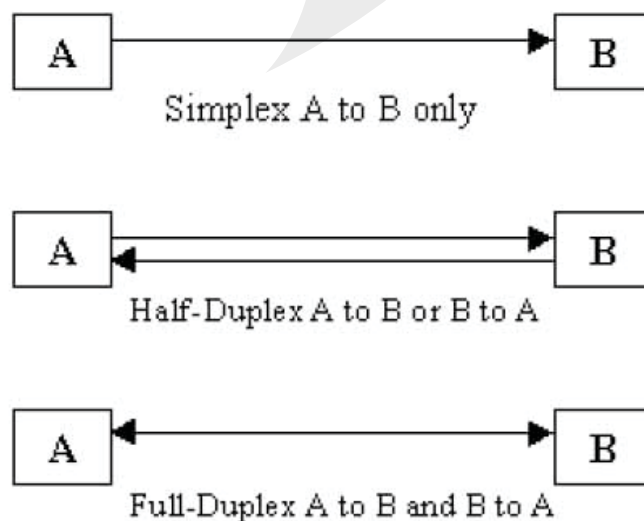

Methods of communication:

There are two different methods communication on the basis of media

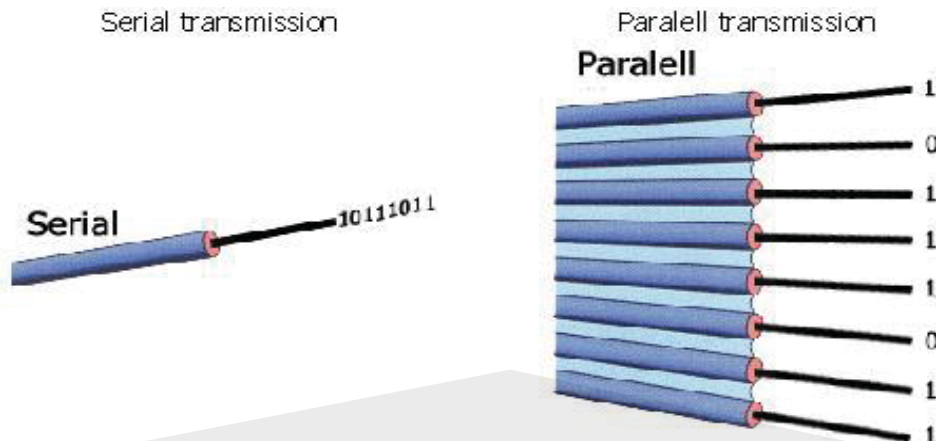
**Serial transmission of data**

Bit by bit transmission of data using single wire is known as Serial Transmission.

It used for external transmission (between two peripheral devices or devices and CPU).

It is slow but more reliable as well as cost effective as only one wire is needed.

Parallel transmission of data

If the devices are connected by more than one wire, then more bits can be sent simultaneously. A sensible number of wires would be eight, because then a whole byte can be sent at the same time.

This method of data transfer is called **parallel data transmission**.

USB (Universal Serial Bus):

Universal Serial Bus (USB) is a plug-and-play interface that allows a computer to communicate with peripheral and other devices.



1. It is a BUS as it has wires to transmit data.
2. It is UNIVERSAL as it connects devices cover a broad range; anything from keyboards and mice, to music players and flash drives.
3. It is SERIAL as in USB data is transmitted bit by bit. USB has 4 cables of which 2 are used for power supply (0V and 5V), 1 to send data from PC to peripheral and 1 to receive data from peripheral.

Error Detection Methods

Following are the methods of error detection during data transmission

Echo Check

The simplest way of checking the transfer of the data is to send the data back again. If the data sent back are the same as the data sent in the first place then the original data must have reached the destination unaltered. If not, the data must be sent again. This is known as echoing back. Echoing back is very effective, but suffers from having to send data twice. The transmission mode needs to be either duplex or half duplex to allow data transfer in both directions.

Parity check

A parity check is a single bit which is added to the end of the message, and indicates that the number of ones in the message is even or odd. If a single error occurs, the receiver could detect it because parity bits will no longer match.

Checksum

Data are normally sent as blocks of bytes rather than as individual bytes. Whatever the data represent, they are in binary form and hence could be treated as numbers that can be added together. Another checking procedure is to add all the bytes that are being sent in the block of data. Any bits lost at the most-significant end as a carry are ignored, so the answer is an eight-bit number. This “check byte” or **checksum** is calculated before the data are sent and then calculated again when they are received. If there are no errors in the transmission, the two answers match. If, however, the two bytes are different there must be at least one checksum that has been corrupted and the whole block of data has to be re-sent.

Sort the steps for Check Sum into order. Write the correct number in the column Step No.

Steps of Check Sum	Step No.
The block of data is sent along with check sum.	
The check sum is calculated and added to the block of data.	
The computer then compares its calculated check sum with the check sum received.	
If the two don't match, then the there is an error in data transmission	
The receiving computer calculates check sum.	

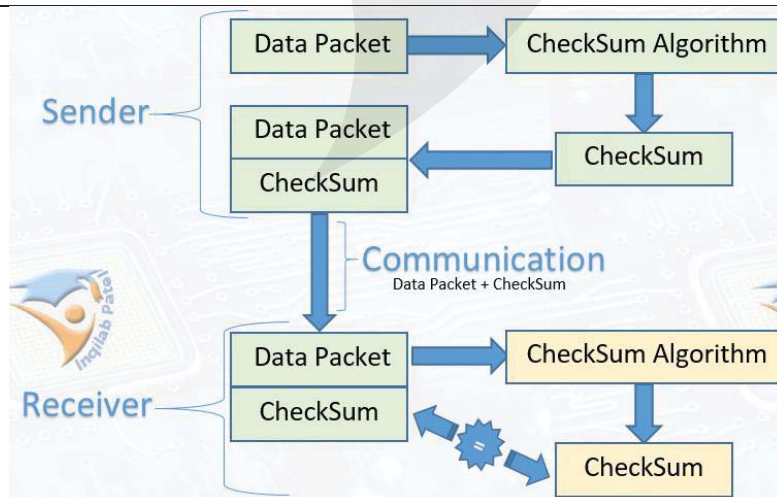

AUTOMATIC REPEAT REQUEST (ARQ)

https://en.wikipedia.org/wiki/Automatic_repeat_request

Automatic Repeat reQuest (ARQ), also known as **Automatic Repeat Query**, is an error-control method for data transmission that uses acknowledgements (messages sent by the receiver indicating that it has correctly received a packet) and timeouts (specified periods of time allowed to elapse before an acknowledgment is to be received) to achieve reliable data transmission over an unreliable service. If the sender does not receive an acknowledgment before the timeout, it usually transmits the packet until the sender receives an acknowledgment or exceeds a predefined number of retransmissions.

Sort the steps for ARQ into order. Write the correct number in the column Step No.

Steps of ARQ	Step No.
Sending computer transmits a block of data	
After a set period of time, a timeout occurs which triggers the data to be automatically resent by the sending computer.	
The sending computer waits for a period of time to see if receiving computer acknowledges receipt of the data.	
This will continue until the receiving computer acknowledges the data has been received.	

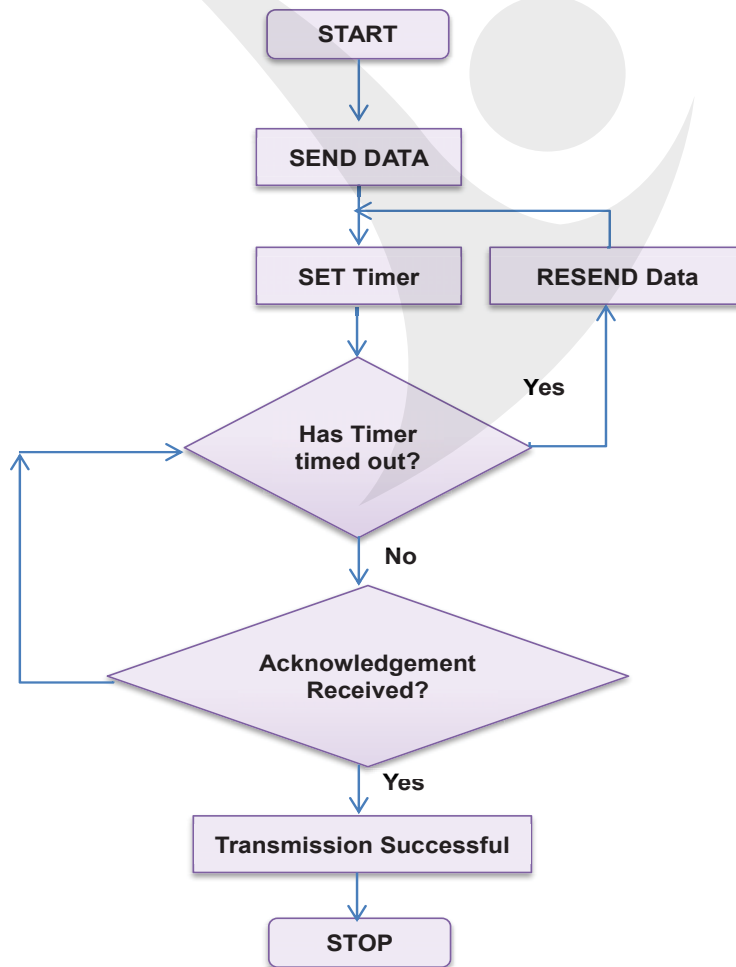

Check digit

A check digit is a digit added to a string of numbers for error detection purposes. Normally, the check digit is computed from the other digits in the string. A check digit helps digital systems detect changes when data is transferred from transmitter to receiver.

Validation technique that involves calculating an additional digit from the ones that precedes it.

Following two Methods are used to calculate check digit

Modulo-11 Method:

- (i) The position of each digit is first considered:

10	9	8	7	6	5	4	3	2	1	← Digit Position
0	2	2	1	4	3	2	5	6	?	← Number
- (ii) Each digit in the number is then multiplied by it's digit position and the totals are added together:
 i.e. $(0 \times 10) + (2 \times 9) + (2 \times 8) + (1 \times 7) + (4 \times 6) + (3 \times 5) + (2 \times 4) + (5 \times 3) + (6 \times 2)$
 $= 0 + 18 + 16 + 7 + 24 + 15 + 8 + 15 + 12$
 $= 115$ total
- (iii) The total is then divided by 11 (modulo 11) and the remainder, if any, is subtracted from 11. The answer then gives the check digit.
 i.e. $115 / 11 = 10$ remainder 5
 i.e. $11 - 5 = 6$ (check digit)
 hence, the final number is: 0-221-43256-6
- (iv) If Check digit = 10 then it will be represented by X (a representation of 10 in ROMAN)

Modulo-10 Method:

Modulo-10 method is used in check digit calculation in ISBN 13, where the 13th digit of the ISBN code is calculated using the following algorithm.

Steps

Example

978-3-12-732320-?

1. Find sum of digits at odd position
2. Find sum of digits at even position and multiply result by 3

ISBN 978-0747595823



Sum of digits at odd position												
$9+8+1+7+2+2=29$												
9	7	8	3	1	2	7	3	2	3	2	0	?
Sum of digits at even position x 3												
$3(7+3+2+3+3)=54$												

3. Add both sums $29+54=83$
4. Find Mod10 $83 \text{ MOD } 10=3$
5. If remainder=0 then
 Check digit=0
- Else
 Check digit=10-Remainder $\text{Check digit } 10-3=7$
- ENDIF

Sort the steps for Check Digit into order. Write the correct number in the column Step No.

Steps of Check Digit	Step No.
The human will be asked by computer to re-enter the numerical code	
A cashier at point of sale, scans the barcode of the product	
The check digit is calculated and added to the barcode, product code at the point of manufacture.	
The computer then compares its calculated check digit with the check digit scanned.	
If the two don't match, then there is an error in entering or scanning bar code	
The computer calculates check digit	

Differences and similarities between Checksum and Check Digit

Check Sum	Check Digit
This is a verification method	This is a validation method
A value is calculated on the block of data using an algorithm	A digit is calculated on the item code using an algorithm at point of manufacturing
appended on the block of data	appended on the item code
Receiver recalculates the check sum using same algorithm	At point of sale the check digit is recalculated using same algorithm
If both the checksum are not same, there will be an error in data transmission.	If both the check digits are not same there will be an error in scanning reading item code.

1.2.3 Internet principles of operation

Internet Service Provider (ISP):

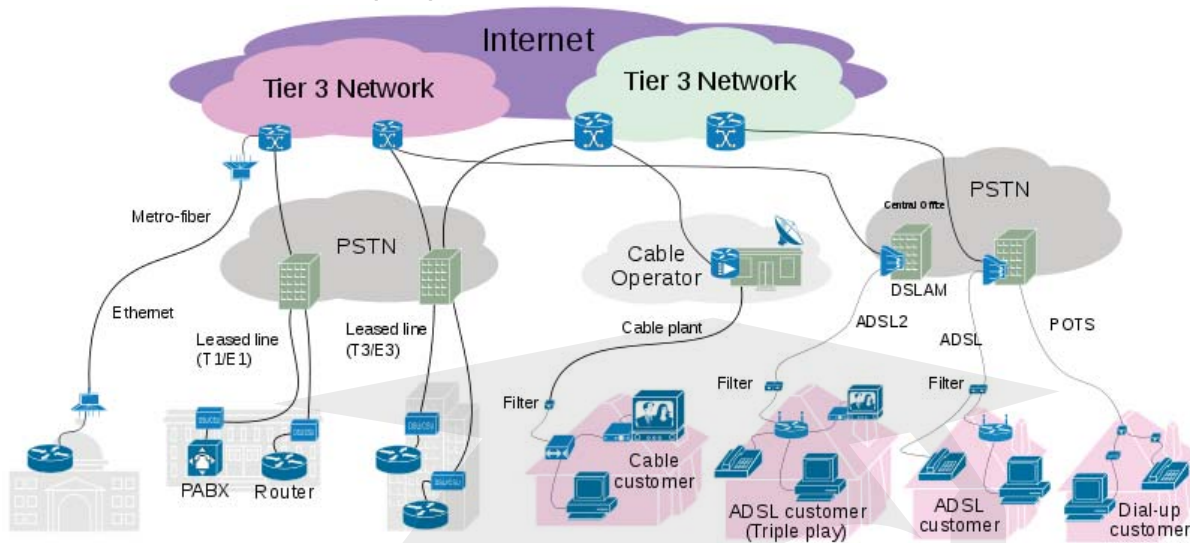

https://en.wikipedia.org/wiki/Internet_service_provider

An **Internet service provider (ISP)** is an organization that provides services for accessing, using, or participating in the Internet. Internet service providers may be organized in various forms, such as commercial, community-owned, non-profit, or otherwise privately owned.

Internet services typically provided by ISPs include Internet access, Internet transit, domain name registration, web hosting, Usenet service etc.

Web browser

<https://www.techopedia.com/definition/288/web-browser>

A web browser is a software program that allows a user to locate, access, and display web pages. Browsers translate web pages and websites delivered using Hypertext Transfer Protocol (HTTP) into human-readable content.

IP Addressing

An Internet Protocol (IP) address is a unique 32-bit reference number that is allocated to devices on a computer network that uses the Internet Protocol.

Although IP addresses are stored as 32-bit numbers, for our convenience they are usually displayed as a series of 4 decimal numbers, each one representing 8 bits of the original binary address.

32-bit binary version: 11001001101000000101101101111111

Decimal version: 201.64.182.255

Some IP addresses are reserved for private network ranges e.g.

10.0.0.0 - 10.255.255.255

172.16.0.0 - 172.31.255.255

192.168.0.0 - 192.168.255.255

IPv4

IPv4 is the most widely deployed Internet protocol used to connect devices to the Internet. IPv4 uses a 32-bit address scheme allowing for a total of 2^{32} addresses (just over 4 billion addresses).

IPv6

IPv6 addresses are 128-bit IP address for a total of 3.4×10^{38} computers.

IPv6 is written in hexadecimal and separated by colons.

An example IPv6 address could be written like this: **3ffe:1900:4545:3:200:f8ff:fe21:67cf**

Example Question 2.3:

The table shows four statements about IP addresses.

Tick (✓) to show which of the statements are true.

Statement	True (✓)
The IP address consists of any number of digits separated by single dots (.)	
Each number in an IP address can range from 0 to 255	
IP addresses are used to ensure that messages and data reach their correct destinations	
Public IP addresses are considered to be more secure than private IP addresses	

Internet Server

Internet server (web server) is a special computer, on which websites are stored. Web Server is constantly switched on and connected to the Internet so that each Internet user around the world can access website at all times. This computer is built up with selected high quality components, which can endure incessant work and high load.

HTTP

Short for *Hyper Text Transfer Protocol*, the underlying protocol used by the World Wide Web.

HTTP defines how messages are formatted and transmitted, and what actions Web servers and browsers should take in response to various commands.

Uniform Resource Locator (URL):

URL stands for Uniform Resource Locator. It is the address of a web page. Each page has its own unique web address (URL).

This is how a computer locates the web page that user is trying to find.

An example of a URL is: <http://inqilabpatel.com/computer2210.html>.

In this example

- “http” enables browser to know what protocol is being used to access information in the domain
- “ruknuddin.com” is called the domain name.

c. "computer2210.html" refers to the specific page.

Domain Name Server (DNS):

Domain Name Servers (DNS) are the Internet's equivalent of a phone book. They maintain a directory of domain names and translate them to Internet Protocol (IP) addresses.

- (i) User types URL of a website in web browser address bar.
- (ii) The web browser sends the request of URL to DNS of internet service provider (ISP).
- (iii) DNS searches the IP address of the URL.
- (iv) URL is translated into machine friendly IP address by DNS.
- (v) The translated IP address is sent to browser.
- (vi) Browser sends http get command to the server of the IP address where website is hosted.
- (vii) The web server sends HTML data to the client web browser.
- (viii) Web page is displayed on client's browser.

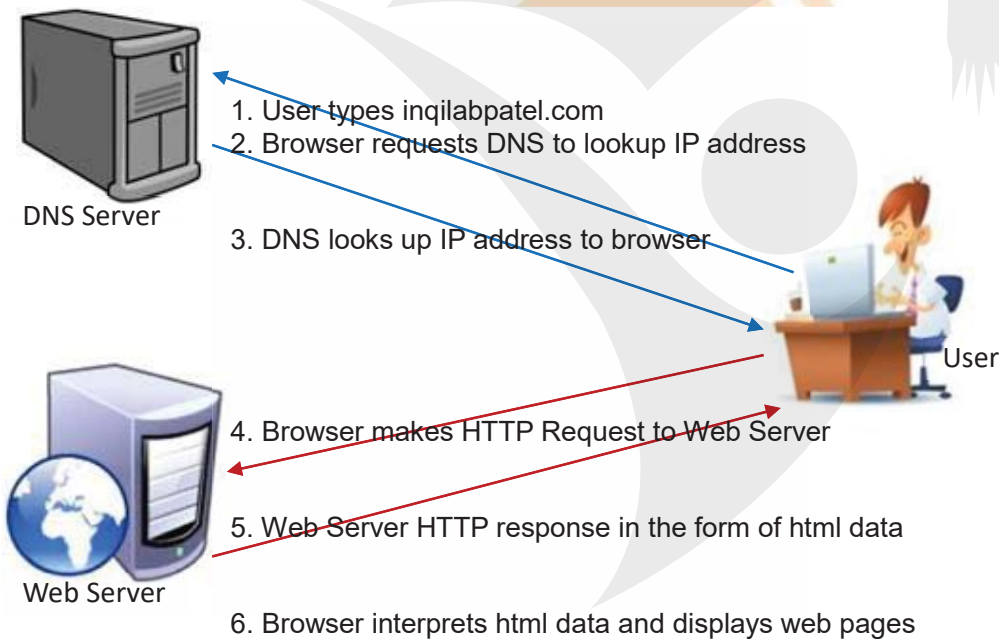

Example Question 2.5:

A web page offers a link for users to request another web page. The requested web page contains HTML code.

Put each statement in the correct sequence by writing the numbers 1 to 5 in the right-hand column.

Statement	Sequence No
The requested web page is displayed on the client computer	
The user clicks on the hyperlink and the web page is requested from the web server	
The requested web page content is transmitted to the client computer	
The client computer processes the html code using the web browser software	
The web server locates the requested web page	

WEB DESIGN

A web page is created by writing code in a language called HTML.

HTML stands for Hyper Text Mark-up Language. It was developed especially to create web pages.

You may be looking at a web page right now and thinking "where is this HTML" - I can't see it.

To see the HTML code of most web pages take these steps:

- View the page in a web browser.
- Right click your mouse over the page text and a small menu will appear close to the mouse (right clicking over a picture gives you a different menu) Click on the "View Source" in the menu list.
- A page full of words and symbols will appear in a separate window

This is the HTML code that makes up the web page you are viewing.

This is what html looks like.

All the coloured text surrounded by <> are html 'tags'.

Creating pages using a text editor

Advantages	Disadvantages
Very flexible as you have complete control of the HTML code	You have to know a lot about HTML code
Low cost - Notepad is free with Windows. And there are plenty of 'freeware' text editors available on the Internet.	Slow, as all the code has to be written by hand.
	Easy to make a mistake.
	You have to save the file and look at it in a web browser to see what it actually looks like.

HTML STRUCTURE is the essential part of the HTML document; it includes the semantics (meaning) and structural mark-up of the document. It is layout of the website. For example placement of headings.

HTML PRESENTATION is the style (formatting) of the website i.e. how the page will look. For example background colour, font size etc. HTML presentation is format of webpage.

Note: Never use design for presentation as it may be consider as layout i.e. structure.

Practice Question) The html has structure and presentation. Tick (✓) to show which of following is structure and presentation:

Example	Structure	Presentation
The colour applied to a text heading on a web page		
The font style applied to a paragraph of text on a web page		
The placement of a paragraph of text on a web page		
The size of an image is set to be displayed at on a page.		
The placement of an image next to a paragraph text on a web page		

Answer Key:

Example	Structure	Presentation
The colour applied to a text heading on a web page		✓
The font style applied to a paragraph of text on a web page		✓
The placement of a paragraph of text on a web page	✓	
The size of an image is set to be displayed at on a page.		✓
The placement of an image next to a paragraph text on a web page	✓	

Topical Questions from Past Papers

18a Summer 21 P11

8 Four 7-bit binary values are transmitted from one computer to another. A parity bit is added to each binary value creating 8-bit binary values. All the binary values are transmitted and received correctly.

(a) Identify whether each 8-bit binary value has been sent using odd or even parity by writing odd or even in the type of parity column. [4]

8-bit binary value	Type of parity
01100100	
10010001	
00000011	
10110010	

(b) An error may not be detected when using a parity check. Identify why an error may not be detected.

..... [1]

(c) The data is sent using parallel half-duplex data transmission.

(i) Describe how data is sent using parallel half-duplex data transmission.

..... [4]

(ii) State two drawbacks of using parallel data transmission.

Drawback 1 [2]
Drawback 2

8(a)	<ul style="list-style-type: none"> - Odd - Odd - Even - Even 	4
8(b)	<p>Any one from:</p> <ul style="list-style-type: none"> - there is a transposition of bits - it does not check the order of the bits (just the sum of 1s/0s) - even number of bits change - incorrect bits still add up to correct parity 	1
8(c)(i)	<p>Four from:</p> <ul style="list-style-type: none"> - Multiple bits are sent at the same time - Uses multiple wires - Data is sent in both directions ... - ... but only one direction at a time 	4
8(c)(ii)	<p>Any two from:</p> <ul style="list-style-type: none"> - Bits may arrive skewed - More expensive to setup/manufacture/purchase cable - Limited distance - More prone to interference/error 	2

18b Summer 21 P12

7 Jolene uses HTML to create a website. She separates the HTML into structure and presentation.

(a) (i) Give one example of HTML structure.

..... [1]

(ii) Give two examples of HTML presentation.

1

2 [2]

(b) Explain why Jolene separates the HTML into structure and presentation.

.....

 [2]

7(a)(i)	Any one from: – Placement of text/image – Margins – Line break – Padding NOTE: Any relevant example of structure can be awarded	1
7(a)(ii)	Any two from: – Font colour – Font style – Font size – Background colour – Image size – Border properties NOTE: Any relevant example of presentation can be awarded	2
7(b)	Any two from: – Can easily change/edit the style of the webpage – So, CSS can be used to create a template/style sheet – Can add new content and apply the same style easily – Can re-use the presentation/style for other websites	2

18c Summer 21 P13) 6 Four 7-bit binary values are transmitted from one computer to another. A parity bit is added to each binary value creating 8-bit binary values. All the binary values are transmitted and received correctly.

(a) Identify whether each 8-bit binary value has been sent using odd or even parity by writing odd or even in the type of parity column. [4]

8-bit binary value	Type of parity
01111100	
10010000	
10011001	
00101001	

(b) The 8-bit binary value 10110001 is transmitted and received as 10110010. A parity check does not identify any errors in the binary value received.

State why the parity check does not identify any errors.

.....
 [1]

(c) The data is sent using serial duplex data transmission.

55 | Page

(i) Describe how data is sent using serial duplex data transmission.

.....

 [4]

(ii) State one drawback of using serial data transmission, rather than parallel data transmission.

.....
 [1]

6(a)	<ul style="list-style-type: none"> - Odd - Even - Even - Odd 	4
6(b)	Any one from: <ul style="list-style-type: none"> - There is a transposition of bits - Bits still add up to correct parity 	1
6(c)(i)	<ul style="list-style-type: none"> - Data is sent one bit at a time - Data is sent using a single wire - Data is sent in both direction ... - ... at the same time 	4
6(c)(ii)	Any one from: <ul style="list-style-type: none"> - Data transmission can be slower (than parallel) - Additional data may need to be sent 	1

Q 1) Summer 2015 P11

1 (a) State what is meant by the terms:

Parallel data transmission:

Serial data transmission: [2]

(b) Give **one** benefit of each type of data transmission.

Parallel data transmission Benefit:

Serial data transmission Benefit: [2]

(c) Give **one** application of each type of data transmission. Each application must be different.

56 | Page

Parallel data transmission Application:

Serial data transmission Application: [2]

2 (a) State what is meant by the term USB.

..... [1]



57 | Page

(b) Describe **two** benefits of using USB connections between a computer and a device.

1:

.....

.....

2:

.....

..... [2]

Examiner’s Comments on Question 2 (a) and (b)

Most candidates gained a mark for their answer to part (a). This was mainly through stating Universal Serial Bus as the full name for USB. Those candidates that did not provide the name, but instead gave a description also gained a mark. Some candidates in their description mistook USB as a device rather than a method of connection.

In part (b) candidates mainly gained marks by stating that many computers have the ability to connect using USB as it has become a universal and industry standard connection. Most candidates referred to the benefits of a USB device rather than the connection and were unable to gain marks as a result.

4 Choose **six** correct terms from the following list to complete the spaces in the paragraphs below:

- encryption • file name • firewall • HTML tags/text • IP address
- protocol • proxy server • SSL certificate • web server name

A user enters a URL. The web browser breaks up the URL into **three** components:

1

2

3

The web server returns the selected web page. The web browser reads the from the selected page and shows the correctly formatted page on the user’s screen. A is used between the user’s computer and the network to examine the data traffic to make sure it meets certain criteria. To speed up the access to the web pages next time, a is used between the computer and web server; this device uses a cache to store the website home page after it has been accessed for the first time. [6]

Q 2) Summer 2015 P12

5 Parity checks are often used to check for errors that may occur during data transmission.

(a) A system uses **even parity**.

Tick (✓) to show whether the following three bytes have been transmitted correctly or incorrectly.

Received byte	Byte transmitted correctly	Byte transmitted incorrectly
1 1 0 0 1 0 0 0		
0 1 1 1 1 1 0 0		
0 1 1 0 1 0 0 1		

(b) A parity byte is used to identify which bit has been transmitted incorrectly in a block of data. The word "FLOWCHART" was transmitted using nine bytes of data (one byte per character). A tenth byte, the parity byte, was also transmitted. The following block of data shows all ten bytes received after transmission. The system uses even parity and column 1 is the parity bit.

	letter	column 1	column 2	column 3	column 4	column 5	column 6	column 7	column 8
byte 1	F	1	0	1	0	0	1	1	0
byte 2	L	1	0	1	0	1	1	0	0
byte 3	O	1	0	1	0	1	1	1	1
byte 4	W	1	0	1	1	0	1	1	1
byte 5	C	1	0	1	0	0	0	1	1
byte 6	H	0	0	1	0	1	0	0	0
byte 7	A	0	0	1	0	0	1	0	1
byte 8	R	1	0	1	1	0	0	1	0
byte 9	T	1	0	1	1	0	1	0	0
parity byte		1	0	1	1	1	1	1	0

(i) One of the bits has been transmitted incorrectly. Write the byte number and column number of this bit:
 Byte number Column number [2]

(ii) Explain how you arrived at your answer for part (b)(i).

 [2]

(c) Give the denary (base 10) value of the byte: **1 0 1 1 1 1 1 0**
 [1]

(d) A parity check may not identify that a bit has been transmitted incorrectly. Describe one situation in which this could occur.

 [1]

Q 3) Winter 2015 P12

6 (a) Explain what is meant by HTML.

 [3]

59 | Page

(b) HTML uses both structure and presentation.

Describe what is meant by the two terms.

Browser

Signal sent to a processor which may cause a break in execution of the current routine, according to priorities

HTML

Company that provides individual's access to the Internet and other services such as webhosting and emails

Internet service provider

Software application used to locate, retrieve and display content on the World Wide Web e.g. web pages, videos and other files

Interrupt

Hardware identification number that uniquely identifies each device on a network; it is manufactured into every network card and cannot be altered

IP address

Authoring language used to create documents on the World Wide Web; uses tags and attributes

MAC address

Location of a given computer/device on a network; can be a static or dynamic value

Structure:

Presentation: [2]

(c) Explain the function of a web browser.

..... [3]

Q 5) Winter 2015 P11

4 Six computer terms and six descriptions are shown below.
Draw a line to link each term to its appropriate description.[5]

12 Parity checks are used to check for errors during data transmission. A system uses **odd** parity.
(a) Complete the following two bytes of data so that they both have **odd** parity:

	1	1	1	1	0	0	0
	0	0	0	0	1	1	1

(b) Name and describe another method which can be used to check whether data has been correctly transmitted.

Name of method:

Description:

.....

.....[2]

Q 6) Summer 2016 P11 & P13

4 (a) Nikita wishes to print out some documents and connects her printer to the computer using one of the USB ports.

(i) Identify what type of data transmission is being used.

.....[1]

(ii) Give three reasons for using a USB port.

1

2

3 [3]

9 Check digits are used to ensure the accuracy of entered data.

A 7-digit number has an extra digit on the right, called the check digit.

digit position:	1	2	3	4	5	6	7	8
digit:	-	-	-	-	-	-	-	-

↑
check digit

The check digit is calculated as follows:

- each digit in the number is multiplied by its digit position
- the seven results are then added together
- this total is divided by 11
- the remainder gives the check digit (if the remainder = 10, the check digit is X)

(a) Calculate the check digit for the following number. Show all your working.

4 2 4 1 5 0 8 ...

.....
.....
.....

Check digit [2]

(b) An operator has just keyed in the following number:

3 2 4 0 0 4 5 X

Circle below correct if the check digit is correct OR incorrect if the check digit is incorrect.

Correct

incorrect

Explain your answer.

.....

.....

.....

.....

..... [3]

Q 7) Summer 2016 P12

6 (a) Three descriptions of data transmission are given below.

[6]

Tick (✓) the appropriate box in each table to show the:

- type of transmission
- method of transmission

Description 1:

Data is transmitted several bits at a time down several wires in both directions simultaneously.

Type	Tick (✓)
simplex	
half-duplex	
full-duplex	

Method	Tick (✓)
serial	
parallel	

Description 2:

Data is transmitted in one direction only, one bit at a time, down a single wire.

Type	Tick (✓)
simplex	
half-duplex	
full-duplex	

Method	Tick (✓)
serial	
parallel	

Description 3:

Data is transmitted one bit at a time down a single wire; the data is transmitted in both directions but not at the same time.

Type	Tick (✓)
simplex	
half-duplex	
full-duplex	

Method	Tick (✓)
serial	
parallel	

62 | Page

(b) Give **two** reasons why serial transmission, rather than parallel transmission, is used to connect devices to a computer.

- 1
- 2 [2]

11 Describe the use of structure and presentation in a HTML document.

-
- [4]

Q 8) Winter 2016 P12

3 (b) A computer in a factory is connected to a printer. The printer is located in an office 1km away from the factory.

Identify which data transmission method would be most suitable for this connection.

.....
Give two reasons for your choice.

- 1
- 2 [3]

Q 9) Winter 2016 P11& 13

3 Five computer terms and seven descriptions are shown below.

Draw a line to connect each computer term to its correct description.

[5]

Computer term	Description
Serial, simplex data transmission	Several bits of data sent down several wires, in both directions, but not at the same time
Parallel, half-duplex data transmission	Several bits of data sent down several wires, in both directions, at the same time
Parity check	An even or odd number of bits set to 1 in a byte, used to check if the byte has been transmitted correctly
Automatic repeat request (ARQ)	One bit sent at a time, over a single wire in one direction only
Checksum	An additional digit placed at the end of a number to check if the number has been entered correctly
	A value transmitted at the end of a block of data; it is calculated using the other elements in the data stream and is used to check for transmission errors
	An error detection method that uses response and time out when transmitting data; if a response is not sent back to the sender in an agreed amount of time, then the data is re-sent

64 | Page

5 (c) A microprocessor regularly samples the output, X. Each sample value is stored in an 8-bit register as shown below. One bit of this register is reserved as a parity bit. Five consecutive output values of 1 indicate a fault condition. Identify which of the following registers shows a fault condition.

Parity bit

1	1	1	1	1	0	0	1
0	1	0	1	1	1	1	1

Register Y

Register Z

Register [1]

(d) When eight bytes of data have been collected, they are transmitted to a computer 100km away. Parity checks are carried out to identify if the data has been transmitted correctly. The system uses **even parity** and column 1 is the parity bit.

The eight bytes of data are sent together with a ninth parity byte:

	parity bit	column 2	column 3	column 4	column 5	column 6	column 7	column 8
byte 1	1	0	0	0	0	1	0	0
byte 2	1	1	1	1	0	0	1	1
byte 3	0	1	0	0	1	0	0	0
byte 4	0	1	1	1	0	0	0	1
byte 5	1	0	0	0	1	1	1	1
byte 6	0	0	0	0	0	0	0	0
byte 7	1	1	1	0	1	0	0	0
byte 8	1	0	0	0	1	1	1	0
Parity byte	1	0	1	1	0	1	1	1

(i) Identify which of the eight bytes contains an error.
byte [1]

(ii) Identify which column contains an error.
column [1]

(iii) The incorrect bit is indicated where the byte number and column cross.
Give the corrected byte. [1]

--	--	--	--	--	--	--	--

(iv) Calculate the denary value of the corrected byte.
..... [1]

(v) Considering the fault condition given in part (c), explain why it is very important that the incorrect bit is located and corrected.

.....

.....

.....

..... [2]

Q 10) March 2017 India

5 Give the meaning of the following terms.

HTML
http
https [3]

Q 11) Summer 2017 P11

4 Five statements about **serial half-duplex** data transmission are shown in the table below. Tick (3) to show whether each statement is **true** or **false**. [5]

Statement	true	false
Data is transmitted in one direction only, one bit at a time.		
Data is transmitted in both directions, multiple bits at a time.		
Data is transmitted in one direction only, multiple bits at a time.		
Data is transmitted in both directions, but only one direction at a time. Data is transmitted one bit at a time.		
Data is transmitted in both directions, but only one direction at a time. Data is transmitted multiple bits at a time.		

Q 12) Summer 2017 P12

4 There are various methods used to detect errors that can occur during data transmission and storage.

Describe each of the following error detection methods.

Parity check
.....
.....
Check digit
.....
.....
Checksum
.....
.....
Automatic Repeat request (ARQ)
.....
..... [8]

	Serial	Parallel
Multiple bits are sent and received at the same time.		
Bits are sent one at a time in a single direction.		
Bits are sent using a single wire. Data can be sent or received, but not at the same time.		

(b) **Three** descriptions and **three** types of data transmission are given.

Tick (✓) the correct box to show the **Type** of data transmission for each description. [3]

Description	Type		
	Simplex	Half-duplex	Duplex
Multiple bits are sent and received at the same time.			
Bits are sent one at a time in a single direction.			
Bits are sent using a single wire. Data can be sent or received, but not at the same time.			

Q 18) Winter 2018 P12 7 Six internet terms and **six** definitions are listed. Draw a line to connect each term to a correct definition.

[5]

Internet term	Definition
Browser	A program that allows a user to view web pages
Internet Service Provider (ISP)	The main protocol that governs the transmission of data using the Internet
Hyper Text Transfer Protocol (HTTP)	The website address that is typed into the address bar
Uniform Resource Locator (URL)	An address given to each device on a network. It is provided by the network
MAC address	A unique address given to a device on a network. It is provided by the manufacturer
IP address	A company that provides a connection to access the Internet

Q 20) March 2019 P12

4 Darius is writing a computer program that allows binary values to be calculated.

Darius is sending several programs that he has created to his friend Selma.

(d) Errors can occur when data is transmitted, stored or entered into a system.

Darius could use an error detection method to find whether errors have occurred.

One error detection method he could use is a checksum.

(i) Describe how a checksum detects errors.

..... [5]

(ii) State **three** other error detection methods that Darius could use.

Method 1

Method 2

Method 3 [3]

6 Nadia purchases a printer to print out her homework.

She connects the printer to her computer using USB.

(a) Explain what is meant by USB. [3]

Q 21) Summer 2019 P11

1 (b) Explain what is meant by a MAC address. [4]

Q 22) Summer 2019 P12

6 Priya creates a website to sell her old comic books and superhero figures.

(a) She uses HTML to create her website. The HTML she produces has both structure and presentation.

Explain what is meant by HTML **structure** and **presentation**. Include an **example** of each. [4]

(c) Priya stores her website on a web server.

To transmit the website data to the web server she uses parallel duplex data transmission.

Describe how data is transmitted using parallel duplex data transmission.

.....
.....
.....
.....
.....
.....
.....
.....

..... [4]

69 | Page

(d) Priya has a URL for her website. State what is meant by a URL.

..... [1]

3 Blair writes a paragraph about data transmission in her Computer Science examination. Use the list given to complete Blair’s paragraph by inserting the correct five missing terms. Not all terms will be used. Terms can be used more than once.

- duplex
- half-duplex
- parallel
- serial
- simplex

..... data transmission is when data is transmitted a single bit at a time. data transmission is when multiple bits of data are sent all at once. If a user wants to transmit data over a long distance, with the highest chance of accuracy,data transmission should be used. If data needs to be transmitted in one direction only, for example from a computer to a printer, data transmission should be used. If a user has a large amount of data to transmit and this needs to be done as quickly as possible..... data transmission should be used. [5]

Q 24) Winter 2019 P12

7 (b) State **three** functions of a browser.

- 1
- 2
- 3 [3]

(c) The website Gerald visits uses https. Explain what is meant by https.

..... [3]

Q 26) Summer 20 P12

5 Meena uses a browser to research information for her business.

(a) Give **three** functions of a browser.

- 1
- 2
- 3 [3]

Q 28) Winter 20 P12

70 | Page

1 Tina is creating a website for charity events. She uses HTML to create the website.

(a) State what is meant by HTML.

..... [1]

(b) She uses the hexadecimal colour code #43B7F0 as the background colour for her website.

(i) State whether background colour is an example of **structure** or **presentation**, in the website.

..... [1]

5 Arjun uses a scanner to create digital versions of some printed documents.

The scanner is attached to his computer using a USB connection.

(a) Tick (✓) to show if the USB connection uses **Parallel** or **Serial** data transmission.

Describe your chosen method of data transmission.

Parallel	<input type="checkbox"/>
Serial	<input type="checkbox"/>

Description

..... [3]

2 Gurdeep sets up a web server to host her website. She reads about an Internet Protocol (IP) address, a Media Access Control (MAC) address and a Uniform Resource Locator (URL).

Draw a line to connect each term to the correct example. [2]

Term	Example
IP address	192.168.0.255
MAC address	https://www.cambridgeinternational.org
URL	00:15:E9:2B:99:3C

1.3.1 Binary Logic

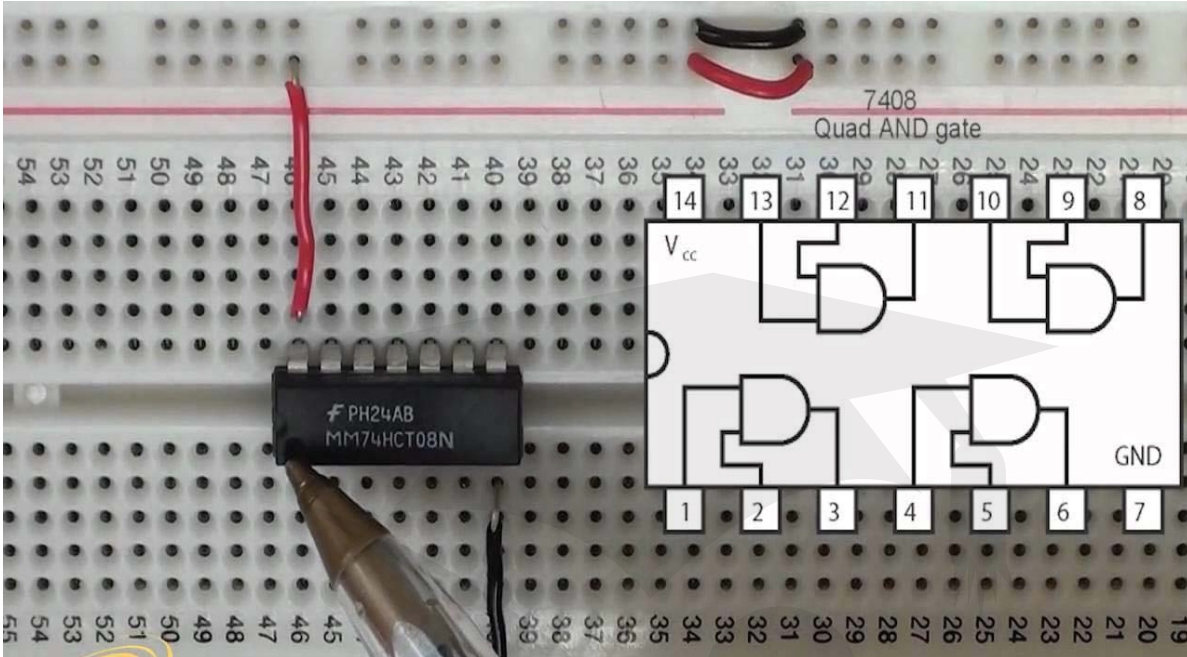

S No	Learning Outcome	To Read	Have Read	To Revise	Have	Prepared
	1.3.1: Logic gates					
22	use logic gates to create electronic circuits					
23	Understand and define the functions of NOT, AND, OR, NAND, NOR and XOR (EOR) gates, including the binary output produced from all the possible binary inputs (all gates, except the NOT gate, will have 2 inputs only)					
24	Draw truth tables and recognise a logic gate from its truth table					
25	Produce truth tables for given logic circuits,					
26	Produce a logic circuit to solve a given problem or to implement a given written logic statement					
27	Write down logic statement of given logic circuit					
28	Simplify the logic circuit					
29	Boolean algebra					
30	Solving past paper questions					

1.3.1 Logic Gates

Many electronic circuits have to make decisions. They look at two or more inputs and use these to determine the outputs from the circuit. The process of doing this uses electronic logic, which is based on digital switches called **Logical Gates**.

Logic gates are devices that can combine multiple inputs at independent logic levels and come up with an output accordingly. They are used by implementing Boolean algebra. Logic gates have two or more input and one output except NOT Gate which has one input and one output.

The most common Logical Gates are given below:

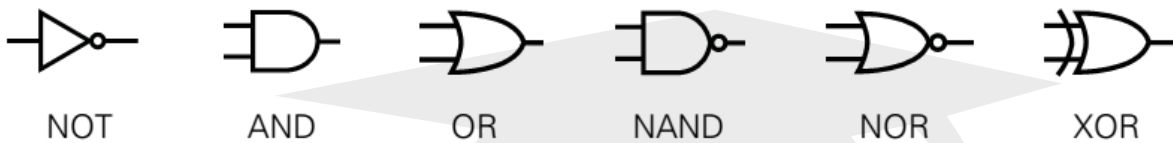

For example, The most obvious use is for simple control. Imagine designing a washing machine so that the water only turns on when the washing is loaded (logic-1), the door is closed (logic-1) but the clothes are not yet wet (logic-0). This can be done by ANDing the first two conditions, and inverting the third. Now, AND these together, and you get a high only when all three conditions are satisfied. Two or more logic gates can be connected to produce a logic circuit with one or more outputs from two or more inputs.

Truth Tables:

“A truth table is used to show the output of a logic gate or circuit for all possible combinations of input values.”

Usually the binary values are used, 1 and 0, as shorthand for True and False.

The truth table for a two-input gate needs four rows ($2^2=4$) while for 3-input gate needs eight rows ($2^3=16$).

(i) NOT Gate (Inverter):

A **NOT gate** or an **inverter** is the simplest kind of logic gate. Its function is to give the opposite output to its input - if it gets a high (1), it gives a low (0), and vice versa. This is equivalent to saying that the output is *not* the input.

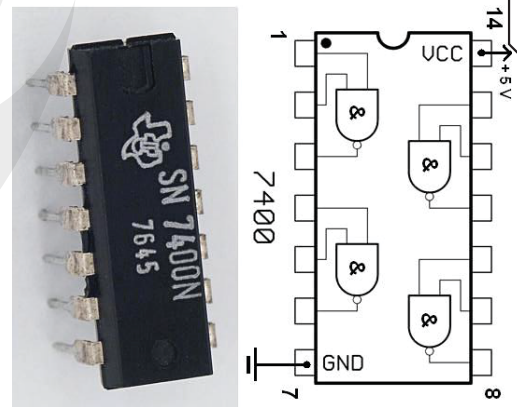

and vice versa.

The output X) =1 if INPUT A is NOT 1(i.e. 0 or OFF).

X = NOT A

X= \bar{A}

NOT Gate	
Input A	Output X
0	1
1	0

73 | Page

(ii) AND Gate

An **AND gate** gives an output 1 only when both inputs are 1. If one or more inputs are 0, then the output is also 0.



Input A	Input B	Output x
0	0	0
0	1	0
1	0	0
1	1	1

The output (called X) is **true** (i.e. 1 or **ON**) only if the (**INPUT A AND INPUT B**) are both **true** (i.e. 1 or **ON**).

The $x=1$ if

INPUT A is 1 AND INPUT B is 1

Or $X = A \text{ AND } B$

Or $X = A \cdot B$ (read as X equals to A AND B)

(iii) OR Gate

An **OR gate** gives an output 1 when **EITHER** input is 1. If any input is 1 output will be 1.



Input A	Input B	Output x
0	0	0
0	1	1
1	0	1
1	1	1

The output (called X) is **true** (i.e. 1 or **ON**) if the (**INPUT A OR INPUT B**) are **true** (i.e. 1 or **ON**).

The OUTPUT $X=1$ IF

Either INPUT A is 1 OR INPUT B is 1

Or $X = A \text{ OR } B$

Or $X = A + B$ (read as X equals to A OR B)

(iv) NAND Gate

This NOT AND combination is shortened to just NAND.

A **NAND gate** gives a 1 only when **BOTH INPUT ARE NOT 1**.

A NAND gate gives 0 output only when both inputs are 1. If one or more inputs are 0, then the output is 1.



Input A	Input B	A AND B	OUTPUT X
0	0	0	1
0	1	0	1
1	0	0	1
1	1	1	0

The output (called X) is **False** (i.e. 0 or **OFF**) if

(**INPUT A = 1 AND INPUT B = 1**) are **NOT** both **true** (i.e. 1 or **ON**). Is 1

Or $X = A \text{ NAND } B$

Or $X = \overline{A \cdot B}$

(v) **NOR Gate**

This NOT OR combination is shortened to just NOR.

A **NOR gate** gives a 1 only when **NEITHER INPUT IS 1**.

A NOR Gate gives 1 as output only if no inputs are 1. If an input is 1, then the output is 0.

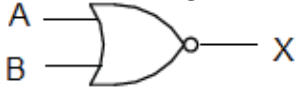

Input A	Input B	A OR B	OUTPUT X
0	0	0	1
0	1	1	0
1	0	1	0
1	1	1	0

The OUTPUT $x=0$ IF

Either INPUT A is 1 OR INPUT B is 1

Or $X = A \text{ NOR } B$

Or $X = \overline{A + B}$

(vi) **XOR Gate**

The '**Exclusive-OR**' gate is a circuit which will give a 1 output if **either, but not both**, of its two inputs are 1. If both inputs are same then output will be 0 else output will be 1



Input A	Input B	Output x
0	0	0
0	1	1
1	0	1
1	1	0

The OUTPUT $X=1$ IF

Either A is 1 AND B is NOT 1

Or A is NOT 1 AND B is 1

Or $X = A \oplus B$

Truth tables

A truth table is used to show the output of a logic gate or circuit for all possible combinations of input values; we usually use the binary values, 1 and 0, as shorthand for True and False.

The truth table for a two-input gate needs four rows.

INPUT		OR	AND	NAND	NOR	XOR
A	B	X	X	X	X	X
		$X = A + B$	$X = A \cdot B$	$X = \overline{A \cdot B}$	$X = \overline{A + B}$	$A \oplus B$
0	0	0	0	1	1	0
0	1	1	0	1	0	1
1	0	1	0	1	0	1
1	1	1	1	0	0	0

Logic circuits

Two or more logic gates can be connected to produce a logic circuit with one or more outputs from two or more inputs. A logic circuit can process logical expressions and binary numbers.

When producing a truth table for a logic circuit:

- it is helpful to add a column for each intermediate output as well as for the final output
- as for a single logic gate with two inputs, a logic circuit with two inputs needs four rows.

Combinational logic circuits with three inputs

We only need to be able to produce a truth table for a logic circuit with a maximum of three inputs and six gates.

The truth table for a three-input logic circuit needs eight rows.

Designing simple logic circuits

Sometimes, it is cheaper to design and hard-wire a logic circuit for a simple automated system that only requires a fixed pattern of output depending on the current values of the inputs, than to program a microcontroller or computer.

We can use the words AND, OR, NOT, NAND and NAND as operators in a logical equation, such as $L = (A \text{ AND } B) \text{ OR NOT } B$. We use brackets to indicate that the logical operation within the brackets takes priority.

We can design a logic circuit to solve a written statement of a logical problem. First, we rewrite the statement using brackets to clarify the binary value of each variable and the priority of the logical operations. Then we can write the logical equation. From the logical equation, if not an earlier stage in the rewriting process, it should be possible to draw the required logic circuit and a truth table to confirm that it has the required behaviour.

Testing logic circuits

We have seen how to use a truth table to check whether a logic circuit has solved a given problem, rather as we use a trace table for dry running a flowchart or pseudo code algorithm. We can also check that a logic circuit solves the problem by building the circuit using logic simulation software or electronic circuitry, with appropriate attention to safety.

Logic Building Block

It is possible to build up any logic gate, using NAND or NOR gates only. NAND and NOR Gates can be used to build any other gates, and called 'logic building block'. It is cost effective for manufacturer to use a single gate to build any logic circuit.

For example, the AND, OR and NOT gates can be built from these gates as shown below:

NAND as NOT:

If single input is given to NAND or NOT gate output will inverted

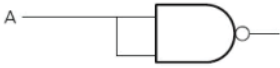

NAND as AND:

NAND on NAND will become AND

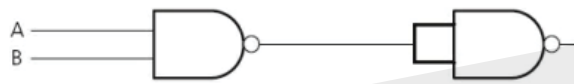

NAND as OR:

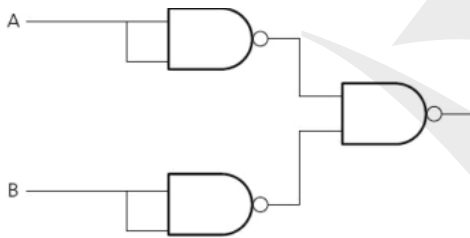

NAND as NOR

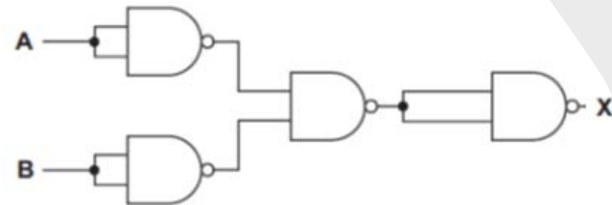

NAND as XOR

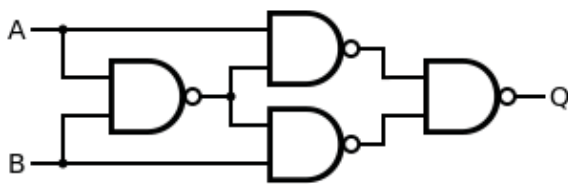

For example

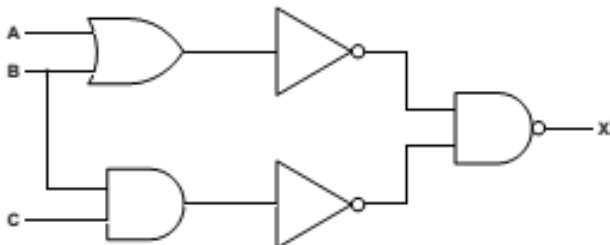

Re-draw the logic circuit shown opposite, using NAND and NOR gates only.

77 | Page

18c Summer 21 P13

8 Consider the following logic circuit:

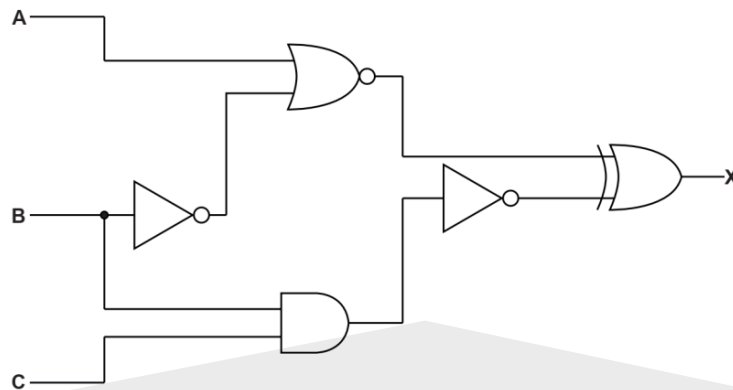

(a) Two NOT gates are used in the given logic circuit.

Identify three other logic gates that are used in the given logic circuit.

- 1
- 2
- 3 [3]

(b) Consider the completed truth table for the given logic circuit.

Row No	A	B	C	Working space	X
1	0	0	0		0
2	0	0	1		1
3	0	1	0		0
4	0	1	1		0
5	1	0	0		1
6	1	0	1		1
7	1	1	0		0
8	1	1	1		1

There are four errors in the truth table in the output (X) column.

Identify the four incorrect outputs. Write the row number to identify each incorrect output.

- Row
- Row
- Row
- Row

[4]

78 | Page

8(a)	<ul style="list-style-type: none"> - AND - NOR - XOR 	3
8(b)	<ul style="list-style-type: none"> - Row 1 - Row 4 - Row 7 - Row 8 	4

18b Summer 21 P12) 3 Consider the logic statement:

$$X = (((\text{NOT } A \text{ AND } B) \text{ OR } C) \text{ AND } B) \text{ NOR } (B \text{ OR } C)$$

(a) Draw a logic circuit to represent the given logic statement.

Do not attempt to simplify the statement. All logic gates must have a maximum of two inputs. [6]

(b) Consider the completed truth table for the given logic statement.

Row No	A	B	C	Working space	X
1	0	0	0		1
2	0	0	1		1
3	0	1	0		1
4	0	1	1		0
5	1	0	0		1
6	1	0	1		0
7	1	1	0		1
8	1	1	1		1

There are four errors in the truth table in the output (X) column. Identify the four incorrect outputs.

Row

Row

Row

Row

[4]

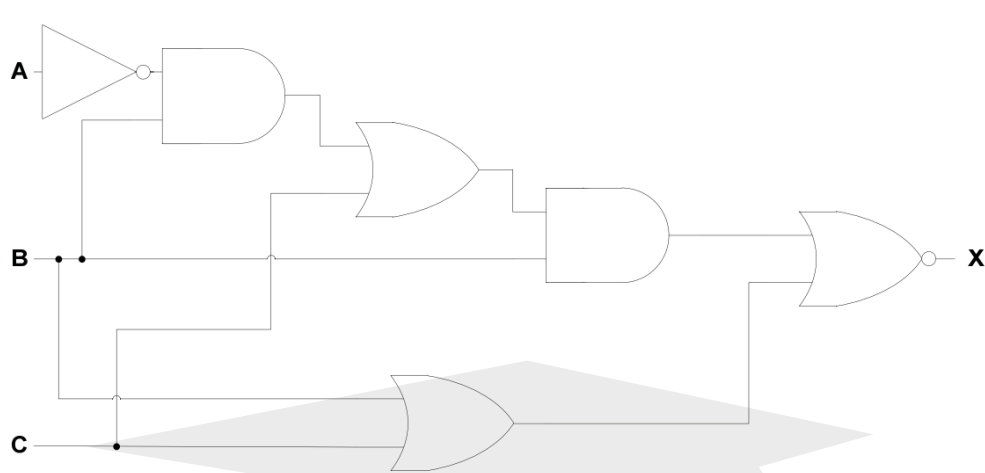
3(a)	<p>One mark for each correct logic gate with correct input.</p> 	6
3(b)	<p>One mark per each correct row.</p> <ul style="list-style-type: none"> - Row 2 - Row 3 - Row 7 - Row 8 	4

18a Summer 21 P13

6 Consider the logic statement:

$$X = ((A \text{ AND } B) \text{ OR } (C \text{ AND } \text{NOT } B)) \text{ XOR } \text{NOT } C$$

(a) Draw a logic circuit to represent the given logic statement.

Do not attempt to simplify the statement. All logic gates must have a maximum of two inputs. [6]

80 | Page

(b) Consider the completed truth table for the given logic statement.

Row number	A	B	C	Working space	X
1	0	0	0		0
2	0	0	1		1
3	0	1	0		0
4	0	1	1		1
5	1	0	0		0
6	1	0	1		1
7	1	1	0		0
8	1	1	1		1

There are four errors in the truth table in the output (X) column.

Identify the four incorrect outputs.

Write the row number to identify each incorrect output.

Row

Row

Row

Row [4]

6(a)	<p>One mark per each correct logic gate, with correct input:</p>	6
6(b)	<ul style="list-style-type: none"> - Row 1 - Row 3 - Row 4 - Row 5 	4

Q 3.1) Identify each of the following gates from truth table:

INPUT 1	INPUT 2	OUTPUT	INPUT 1	INPUT 2	OUTPUT
---------	---------	--------	---------	---------	--------

81 | Page

0	0	0
0	1	1
1	0	1
1	1	1

0	0	1
0	1	1
1	0	1
1	1	0

.....

INPUT 1	INPUT 2	OUTPUT
0	0	0
0	1	0
1	0	0
1	1	1

.....

INPUT 1	INPUT 2	OUTPUT
0	0	0
0	1	1
1	0	1
1	1	0

.....

INPUT 1	INPUT 2	OUTPUT
0	0	1
0	1	0
1	0	0
1	1	0

.....

INPUT 2	OUTPUT
0	1
1	0

.....

.....

82 | Page

Q 3.7a) A greenhouse control system has four input parameters (H, D, T, W) and two outputs (X, Y).

Parameter	Description of parameter	Binary value	Condition
H	Humidity	0	Too low
		1	Acceptable
D	Day	0	Night
		1	Day
T	Temperature	0	Too high
		1	Acceptable
W	Windows	0	Closed
		1	Open

The watering system turns on ($X = 1$) if:

either it is daytime **and** the temperature is too high

or the humidity is too low.

The fan turns on ($Y = 1$) if the temperature is too high **and** the windows are closed.

Draw a logic circuit to represent the greenhouse control system.

[6]



(b) Complete the truth table for the logic expression: $X = \text{NOT } A \text{ AND } (B \text{ NAND } C)$

[4]

A	B	C	Working space	X
0	0	0		
0	0	1		
0	1	0		
0	1	1		
1	0	0		
1	0	1		
1	1	0		
1	1	1		

83 | Page

Q 3.9a) A student needs to design a logic circuit to model the requirements for membership of a snooker club. Membership (X) depends on four criteria, as shown in the table:

Parameter	Description of parameter	Binary value	Condition
A	Over 18	1	True
		0	False
B	Recommended	1	True
		0	False
C	Full-time	1	True
		0	False
D	Retired	1	True
		0	False

Membership is approved ($X = 1$) if the person:

- is over the age of 18 **and** has been recommended by a pre-existing member **and**
- **either** is working full-time **or** is retired, **but not both**.

Draw a logic circuit to represent the membership requirements.



[3]

(b) Complete the truth table for the logic expression: $X = (A \text{ XOR } B) \text{ AND NOT } C$ [4]

A	B	C	Working space	X
0	0	0		
0	0	1		
0	1	0		
0	1	1		
1	0	0		
1	0	1		
1	1	0		
1	1	1		

Technical Update

Cambridge O Level Computer Science 2210

For examination in June and November 2020.



From 2020, logic statements in the Paper 1 examination might not include the output and input values, such as 1 and 0. Therefore candidates must know how to interpret logic statements both with and without input and output values being written in the logic statement.

For example, the logic statement:

$X = 1$ if $((A \text{ is } 1 \text{ OR } B \text{ is } 1) \text{ AND } (A \text{ is } 1 \text{ AND } B \text{ is } 1)) \text{ OR } (C \text{ is NOT } 1)$

Can also be written as:

$X = ((A \text{ OR } B) \text{ AND } (A \text{ AND } B)) \text{ OR } (\text{NOT } C)$

85 | Page

Logic Building Block

It is possible to build up any logic gate, using NAND or NOR gates only.

NAND and NOR Gates can be used to build any other gates, and called 'logic building block'. It is cost effective for manufacturer to use a single gate to build any logic circuit.

For example, the AND, OR and NOT gates can be built from these gates as shown below:

NAND as NOT:

If single input is given to NAND or NOT gate output will inverted

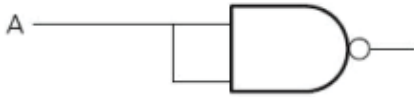
**NAND as AND:**

NAND on NAND will become AND

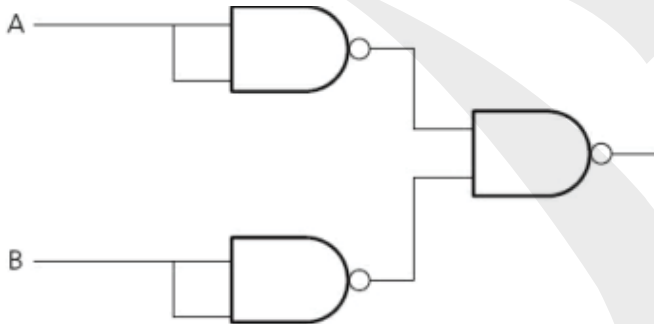
**NAND as OR:**

NAND as NOR

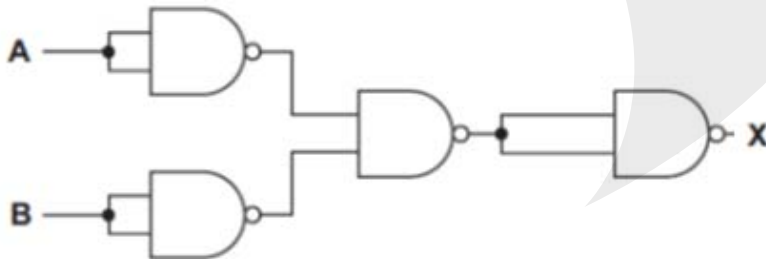

NAND as XOR

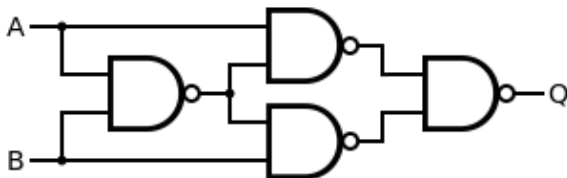

86 | Page

For example

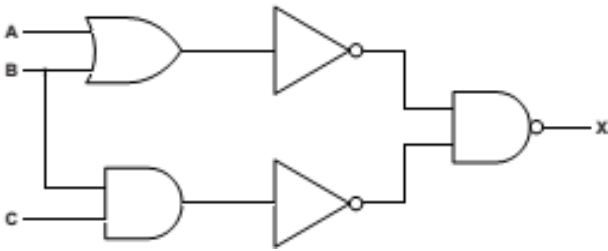

Re-draw the logic circuit shown opposite, using NAND and NOR gates only.

Complete the truth table for following circuits:

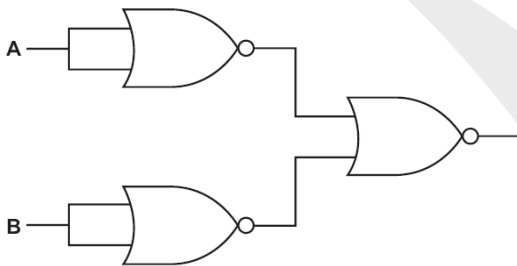

A	B	Working	X
0	0		
0	1		
1	0		
1	1		

Which single gate performs the same function?

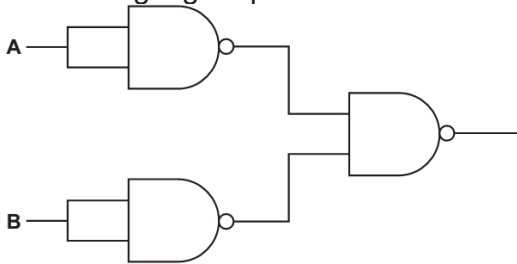

A	B	Working	X
0	0		
0	1		
1	0		
1	1		

Which single gate performs the same function?

87 | Page

Simplification Logic Circuit:

Simplification means reducing the number of components in a logic circuit. As a result of simplification the cost of production can be less. This can also improve reliability and make it easier to trace faults if they occur.

The following logic circuit can be simplified to use only one gate.

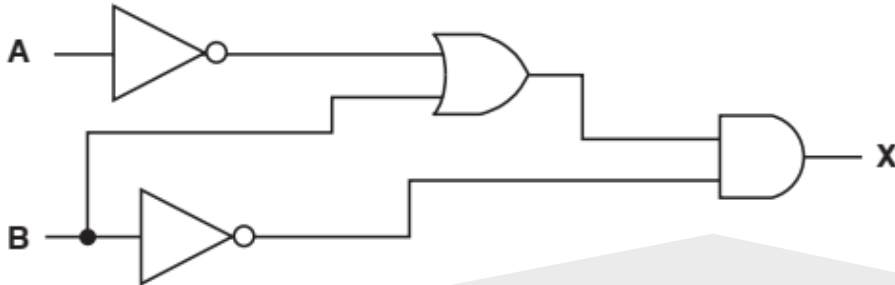

Give the name of this single gate.

..... [1]

Q 3.3)Show by drawing a truth table which single logic gate or what else has the same function as the logic circuit drawn in

a)

INPUT		Workspace	OUTPUT
A	B		X
0	0		
0	1		
1	0		
1	1		

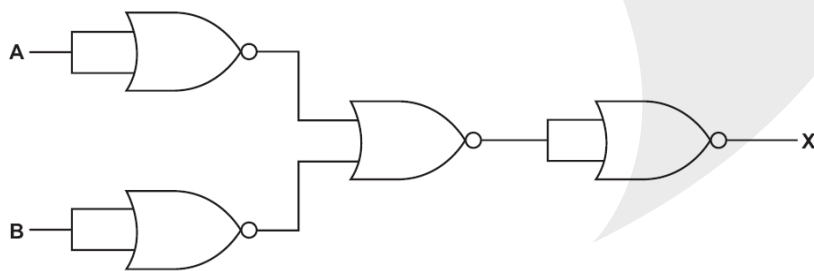

b)

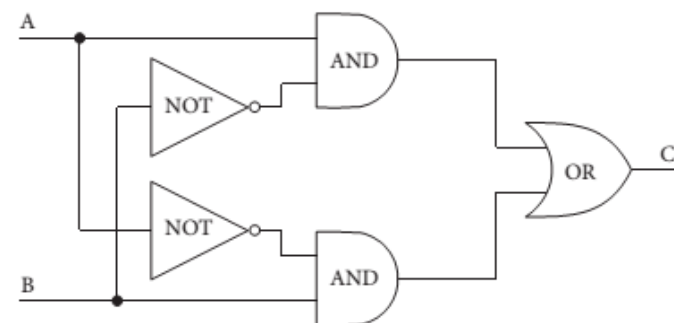

INPUT		Workspace	OUTPUT
A	B		C
0	0		
0	1		
1	0		
1	1		

c)

INPUT		Workspace	OUTPUT
A	B		X
0	0		
0	1		
1	0		
1	1		

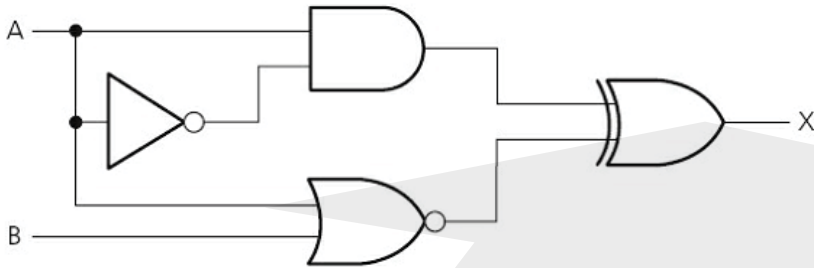

d)

INPUT		Workspace	OUTPUT
A	B		C
0	0		
0	1		
1	0		
1	1		

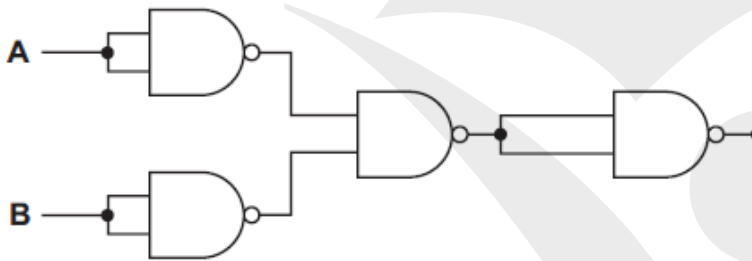

e) Explain why a single logic gate is often replaced by a logic circuit such as shown in part a, b, c and d.

.....

.....

.....[1]

Q 3.4) What could replace the whole logic circuit?

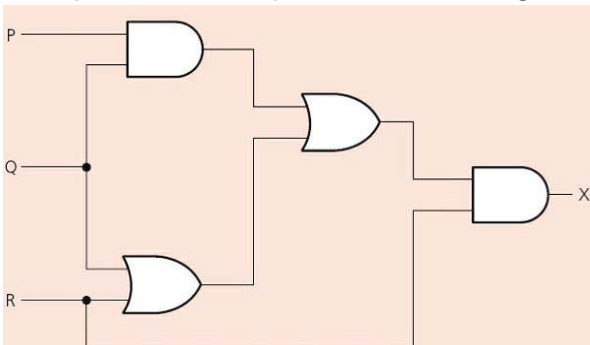

INPUT			Workspace	X
P	Q	R		
1	1	1		
1	1	0		
1	0	1		
1	0	0		
0	1	1		
0	1	0		
0	0	1		
0	0	0		

89 | Page

Multiple output:

Q 3.5) Multiple outputs can be obtained from a logic circuit. For example in the given logic circuit 2 outputs 'S' and 'C' are generated.

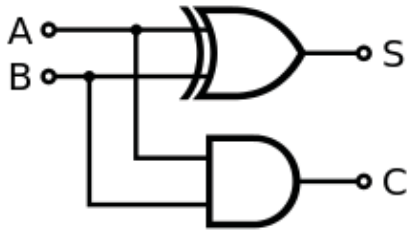

INPUT		OUTPUT	
A	B	S	C
0	0		
0	1		
1	0		
1	1		

Q 6) The following three logic statements define the light sequence:

- R = 1 IF (A is NOT 1)
- G = 1 IF (B is 1 AND C is 1)
- Y = 1 IF (A is 1 AND NOT (B is 1 AND C is 1))

Draw the logic circuit that directly combines ALL three of these logic statements and produces three outputs R, G and Y. [5]



90 | Page

(b) (i) Complete the truth table for the logic circuit.

[2]

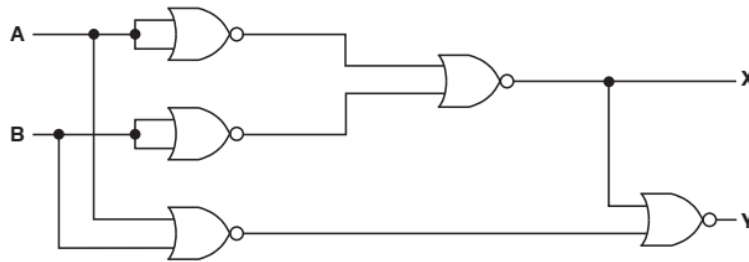

A	B	Working space	X	Y
0	0			
0	1			
1	0			
1	1			

Q 1) Summer 2015 P11

3 (a) Complete the truth table for the following logic circuit:

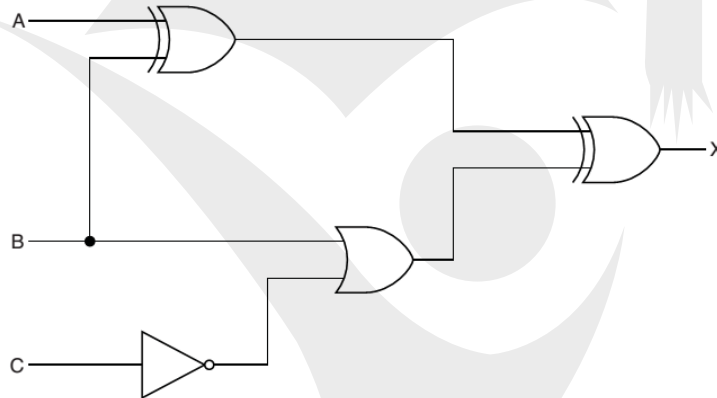

A	B	C	Workspace	X
1	1	1		
1	1	0		
1	0	1		
1	0	0		
0	1	1		
0	1	0		
0	0	1		
0	0	0		

(b) Draw a logic circuit which corresponds to the following logic statement:

$X = 1$ if ((A is NOT 1 OR B is 1) AND C is 1) OR (B is NOT 1 AND C is 1)

(c) Write a logic statement which corresponds to the following logic circuit:

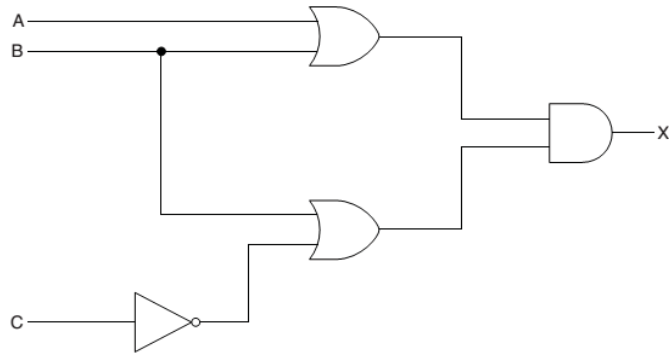

.....
.....
.....[3]

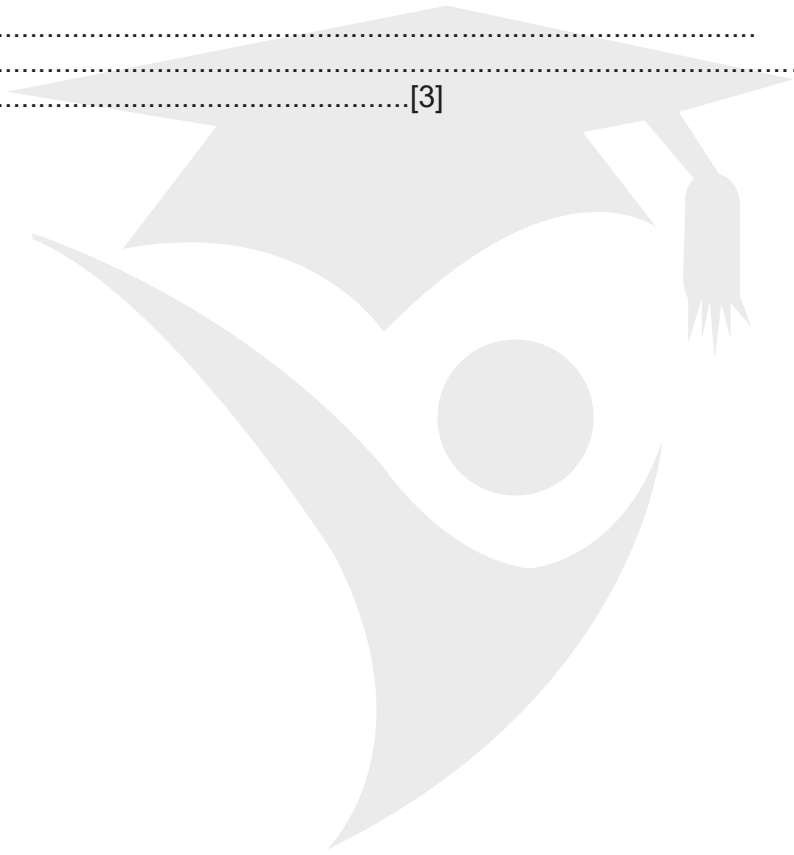

Q 2) Summer 2015 P12

6 A gas fire has a safety circuit made up of logic gates. It generates an alarm (X = 1) in response to certain conditions.

Input	Description	Binary value	Conditions
G	gas pressure	1	gas pressure is correct
		0	gas pressure is too high
C	carbon monoxide level	1	carbon monoxide level is correct
		0	carbon monoxide level is too high
L	gas leak detection	1	no gas leak is detected
		0	gas leak is detected

The output X = 1 is generated under the following conditions:

gas pressure is correct **AND** carbon monoxide level is too high
OR

carbon monoxide level is correct **AND** gas leak is detected

(a) Draw a logic circuit for this safety system. [5]



(b) Complete the truth table for the safety system. [4]

G	C	L	Workspace	X
1	1	1		
1	1	0		
1	0	1		
1	0	0		
0	1	1		
0	1	0		
0	0	1		
0	0	0		

Q 6) Summer 2016 P11 & P13

5 A computer-controlled machine produces plastic sheets. The thickness of each sheet must be within a certain tolerance. The sheets are kept below 50 °C as they move over rollers at 10 metres per second.

Three parameters need to be monitored all the time.

Parameter	Description	Binary value	Conditions
D	sheet thickness	1	thickness of sheet in tolerance
		0	thickness of sheet out of tolerance
S	roller speed	1	roller speed = 10 metres/second
		0	roller speed \neq 10 metres/second
T	Temperature	1	temperature < 50 °C
		0	temperature \geq 50 °C

An alarm, X, will sound if:

thickness is in tolerance AND (roller speed \neq 10 metres/second OR temperature \geq 50 °C)
OR

roller speed = 10 metres/second AND temperature \geq 50 °C

(a) Draw a logic circuit to represent the above monitoring system.

[6]



(b) Complete the truth table for the monitoring system.

[4]

D	S	T	Working Space	X
0	0	0		
0	0	1		
0	1	0		
0	1	1		
1	0	0		
1	0	1		
1	1	0		
1	1	1		

Q 7) Summer 2016 P12

7 (b) Draw a logic circuit corresponding to the following logic statement:
 $X = 1$ if $((A \text{ is } 1 \text{ OR } B \text{ is } 1) \text{ AND } (A \text{ is } 1 \text{ AND } B \text{ is } 1)) \text{ OR } (C \text{ is NOT } 1)$

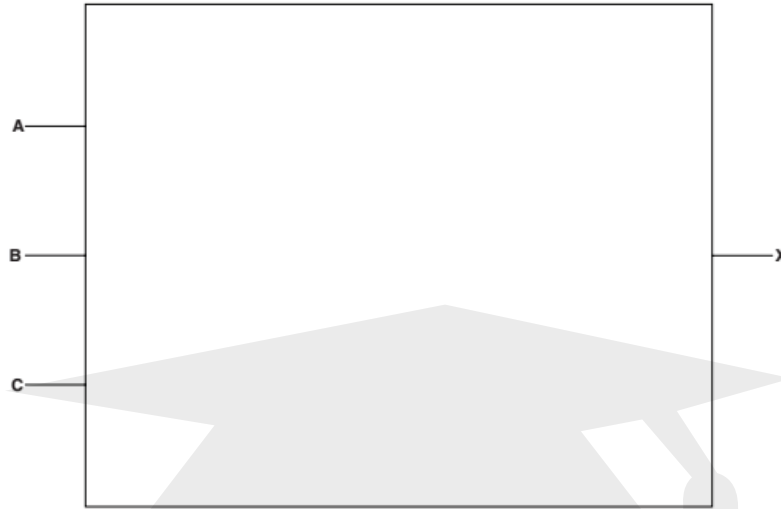

[5]

(c) Re-draw the following logic circuit using NAND gates only.

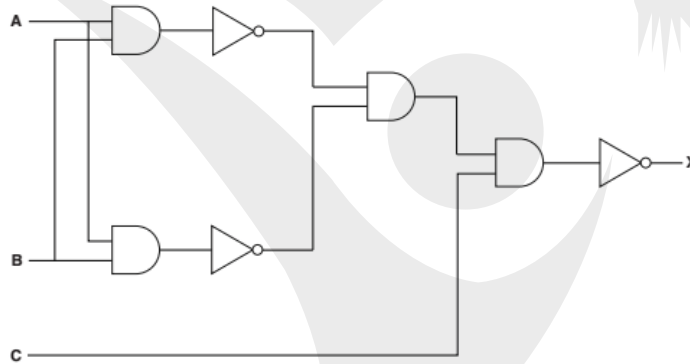

Logic circuit re-drawn:



[4]

Q 8) Winter 2016 P12

7 (a) Complete the truth tables and name the single logic gate that could replace each logic circuit:

(i)

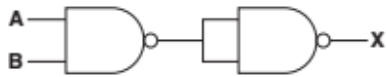

A	B	Working space	X
0	0		
0	1		
1	0		
1	1		

Single logic gate[3]

(ii)

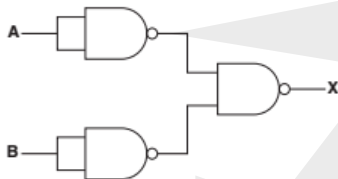

A	B	Working space	X
0	0		
0	1		
1	0		
1	1		

Single logic gate[3]

14 A system controls the flow of vehicles through a barrier based on three lights, A, B and C. When a light is red, the signal is zero. When a light is green, the signal is one. The barrier will open when the output X is one.

The barrier opens if either:

- light A is red and lights B and C are both green
- or
- light A is green and lights B and C are both red

(a) Design a logic circuit for the system

(b) Complete the truth table for the system given at the start of Question 14. [4]

A	B	C	Working space	X
0	0	0		
0	0	1		
0	1	0		
0	1	1		
1	0	0		
1	0	1		
1	1	0		
1	1	1		

96 | Page

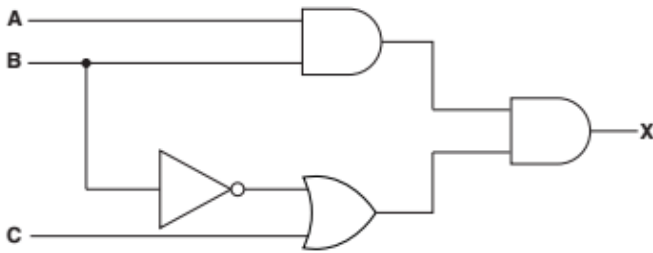
Q 11) Summer 2017 P11**10 (b)** Write a logic statement that corresponds with the following logic circuit.

X = [3]

Q 13) Winter 2017 P12

7 Draw a logic circuit to represent the logic statement: [7]

X = 1 if (A is NOT 1 AND B is 1) AND (A is NOT 1 AND C is NOT 1) OR (B is 1 AND C is 1)

Q 14) Winter 2017 P13

5 (a) Draw a logic circuit for the logic statement:

X = 1 if ((A is 1 AND B is 1) OR (A is NOT 1 AND C is 1))

[4]

97 | Page

(b) Draw the symbol for an XOR gate and explain the function of this logic gate.

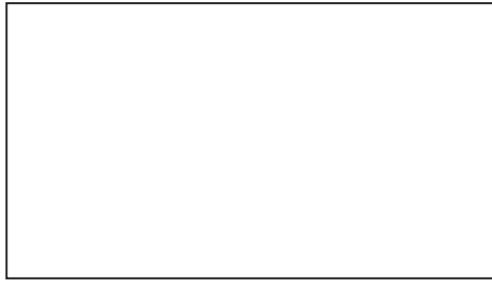

Explanation

 [5]

Q 18) Winter 2018 P12

3 A greenhouse uses a system to monitor the conditions that plants need to grow.

The inputs to the system are:

Input	Binary value	Condition
W	1	Window is open
	0	Window is closed
T	1	Temperature $\geq 26^{\circ}\text{C}$
	0	Temperature $< 26^{\circ}\text{C}$
H	1	Humidity $\geq 50\%$
	0	Humidity $< 50\%$

The system will sound an alarm when certain conditions are detected.

Alarm (X) will sound (=1) when:

window is closed and temperature $\geq 26^{\circ}\text{C}$

or

temperature $< 26^{\circ}\text{C}$ and humidity $\geq 50\%$

Draw a logic circuit to represent the system. [5]

Q 20) March 2019 P12

5 Consider the following logic statement:

$$X = 1 \text{ if } ((A \text{ is } 1 \text{ NAND } C \text{ is } 1) \text{ NOR } A \text{ is NOT } 1) \text{ OR } (B \text{ is } 1 \text{ AND } C \text{ is NOT } 1)$$

(a) Draw a logic circuit that represents the given logic statement. Your logic gates must have a maximum of two inputs. Do **not** simplify the logic statement. [6]



(b) Complete the truth table for the given logic statement. [4]

A	B	C	Working space	X
0	0	0		
0	0	1		
0	1	0		
0	1	1		
1	0	0		
1	0	1		
1	1	0		
1	1	1		

Q 21) Summer 2019 P11

2 Rajesh creates a logic circuit.

He uses three different logic gates in his circuit. Each logic gate has a maximum of two inputs.

He describes the logic of each gate.

(a) "The only time the output will be 1 is when both inputs are 1."

State the single logic gate

Draw the single logic gate:

[2]

(b) "The only time the output will be 1 is when both inputs are 0."

State the single logic gate

Draw the single logic gate:

[2]

(c) "The only time the output will be 0 is when both inputs are 1."

State the single logic gate

Draw the single logic gate:

[2]

Q 24) (b) A water control system uses a switch and two pressure sensors.

The outputs of the switch and sensors are shown in the table.

Sensor or Switch	Output of 1	Output of 0
Switch (S1)	On	Off
Pressure Sensor (P1)	≥ 3	< 3
Pressure Sensor (P2)	≥ 3	< 3

Create a logic circuit that will produce an output (X) of 1 when:

The switch S1 is on

and

either P1 is less than 3 or P2 is less than 3, but not both.

All logic gates used must have a maximum of two inputs.

[4]

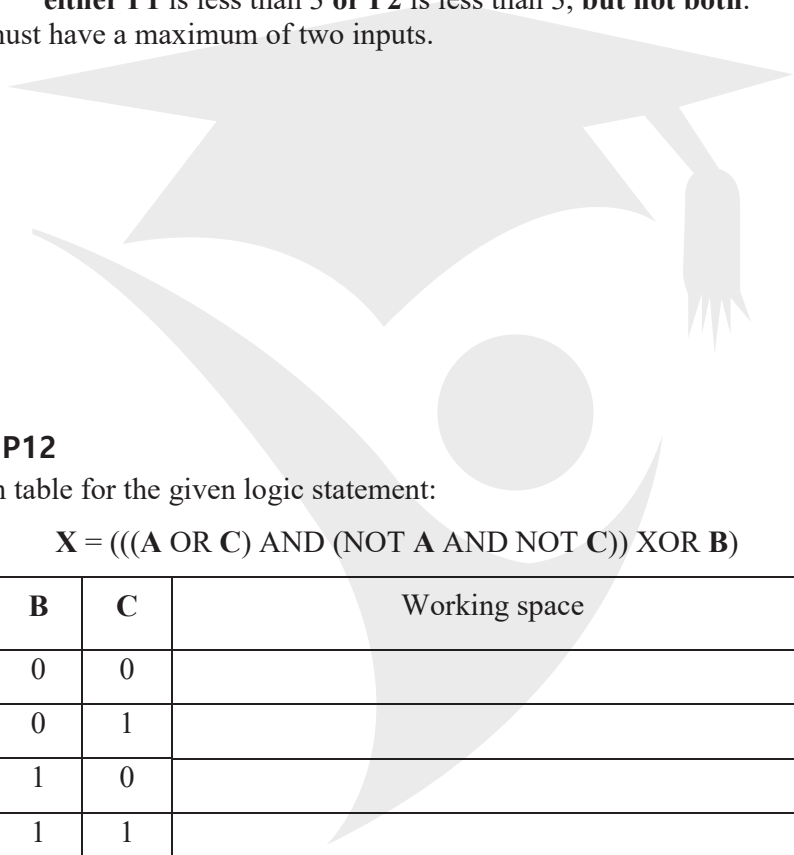

Q 26) Summer 20 P12

(b) Complete the truth table for the given logic statement:

[4]

$$X = (((A \text{ OR } C) \text{ AND } (\text{NOT } A \text{ AND } \text{NOT } C)) \text{ XOR } B)$$

A	B	C	Working space	X
0	0	0		
0	0	1		
0	1	0		
0	1	1		
1	0	0		
1	0	1		
1	1	0		
1	1	1		

1.3.2 Computer Architecture

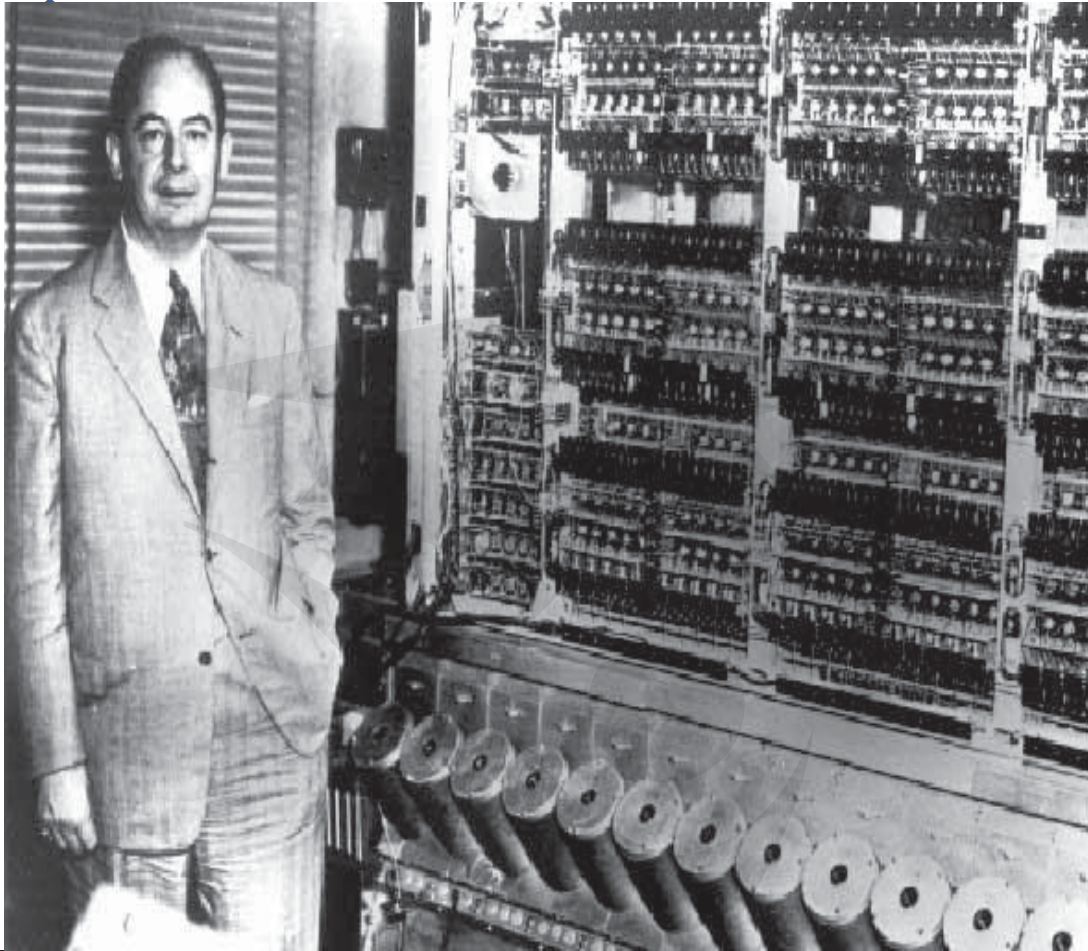

Learning Outcome	To Read	Have Read	To Revise	Have Revised	Prepared
1.3.2: Computer architecture and the fetch-execute cycle					
Show understanding of the basic Von Neumann model for a computer system and the stored program concept (program instructions and data are stored in main memory and instructions are fetched and executed one after another)					
Describe the stages of the fetch-execute cycle					

Von Neumann Architecture

The idea about how computers should be built was proposed by John von Neumann in 1945.

102 | Page

Von Neumann gave an idea how to build computer. This idea is also called the **von Neumann Architecture** or **Model**.

A computer should have input/output devices, Arithmetic Logic Unit (ALU), Control Unit (CU) and computer memory (storage device).

Firstly programs should be stored in computer's memory (storage devices). From storage devices programs should be loaded into CPU (ALU & CU) for execution.

This is still the basis for computers today.

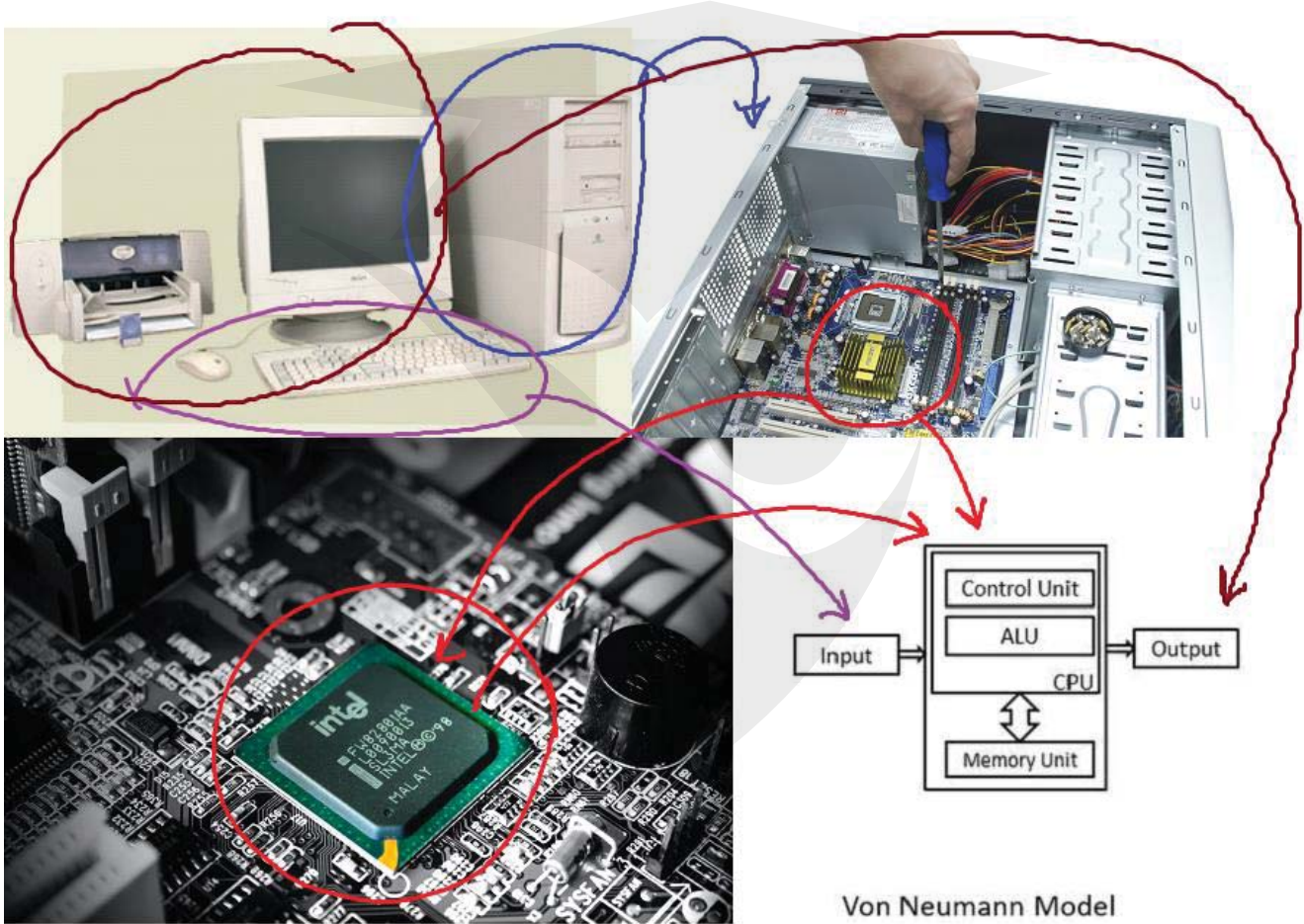

Von Neumann Model

Stored Program Concept:

The idea given by von Neumann, according to this concept computer should have storage device to store data and instruction to be processed. Data and instructions are first stored in secondary storage (HDD or SSD). Then they are loaded in main memory (RAM). From main memory data and instructions are fetched in registers inside CPU. Decoder of CU decodes the instruction and ALU executes the instructions and results are stored firstly in main memory and then in secondary storage.

Examiner Comments on Question to explain Stored Program Concept

This question appeared to be very challenging for candidates. Many candidates described the fetch execute cycle. It would be helpful if candidates understood that the stored program concept is a specific infrastructure for the central processing unit and not the fetch execute cycle. It would be encouraging to see candidates demonstrate a more confident level of knowledge of the stored program concept.

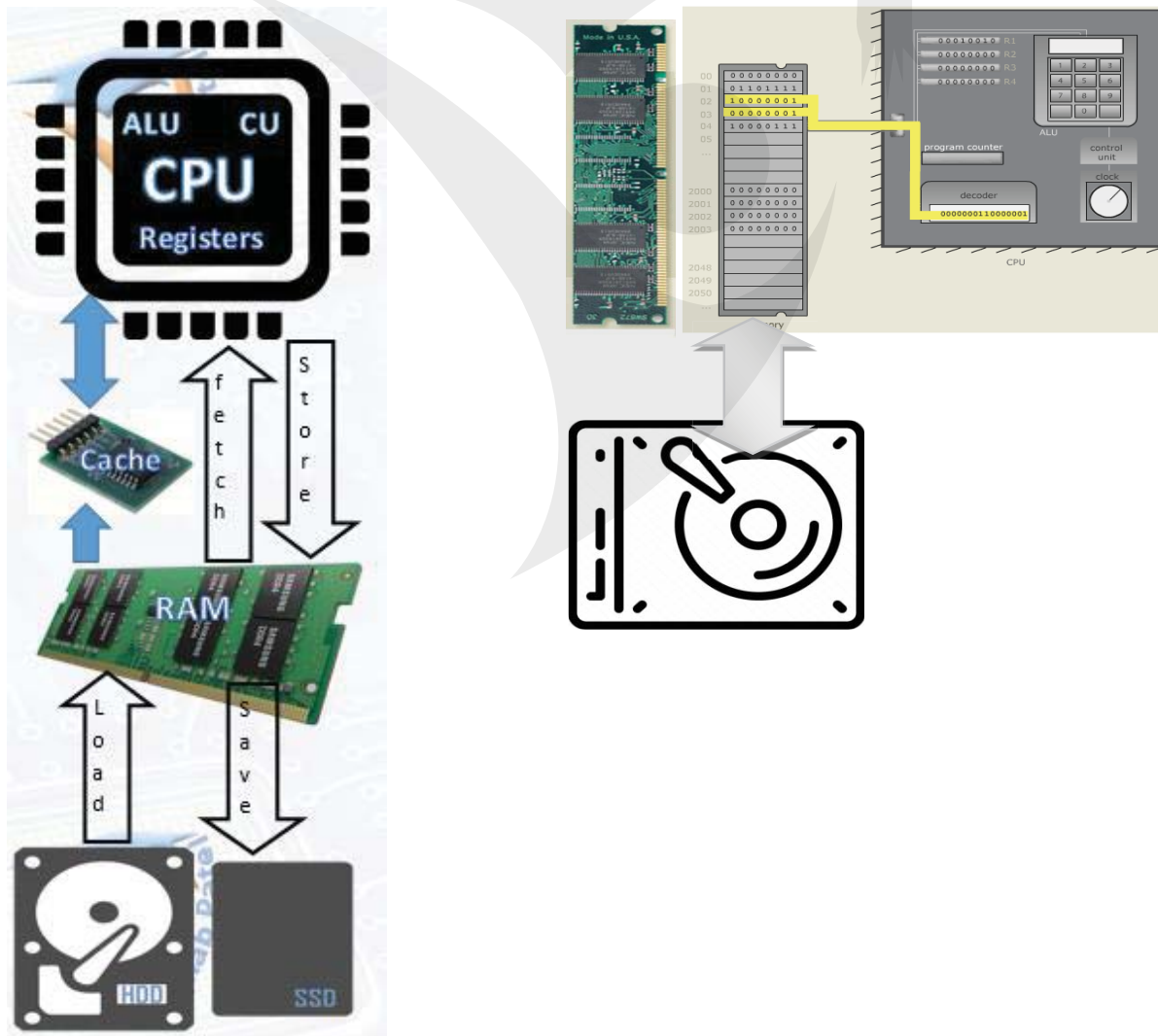

Components of von Neumann Model

Von Neumann Model has following four components:

1. Input/Output Devices
2. Memory Unit
3. Control Unit
4. Arithmetic Logic Unit

Input/output (I/O) Devices

The Input/output (I/O) components of a computer are hardware devices that are responsible for getting data from the computer to the user or from the user to the computer.

Data going from the user to the computer is called "input." The two main input devices are the mouse and the keyboard.

Output devices are used to transmit data from the computer's memory to the user. The two output devices almost every computer system has are the monitor and the printer.

Memory Unit

Computer has several types of memory. Memory unit in the Von Neumann model is the main memory, also called RAM or Random Access Memory. It also refers as Immediate Access Store (IAS).

Immediate Access Store (i.e. main memory) holds data and instructions when they are waiting to be processed.

What distinguishes a computer from a calculator is the ability to run a stored program; main memory allows the computer to do that.

RAM can be thought of as a sequence of boxes, called cells, each of which can hold a certain amount of data.

The remaining three components of the von Neumann model of a computer are found inside the Processor.

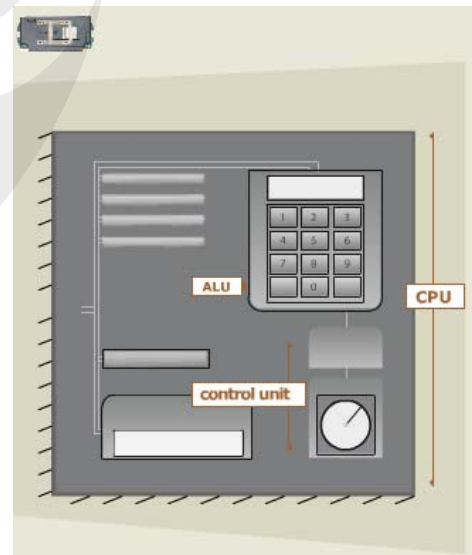

Control Unit

The control unit controls the sequencing and timing of all operations. It contains a "clock," that is actually a quartz crystal that vibrates million times per second. The clock emits an electronic signal for each vibration. Each separate operation is synchronized to the clock signal. For example 1st pc operates at 4.7 MHz means 4.7 million instructions per second.

The functions of CU are given below:

- It controls and monitors all activities of computer
- It controls speed of processing using system clock
- It fetches instructions from memory into CPU
- It decodes the instructions.

Arithmetic & Logic Unit (ALU)

Arithmetic unit perform arithmetical operations like +, -, *, and / while logical unit are to compare two quantities. Logical operations are important in computer programming.

ALU can be thought of as being similar to a calculator, except that, in addition to normal math, it can also do logical (true/false) operations.

The functions of ALU are given below:

- The arithmetic unit carries out arithmetic like addition, division.
- The logic unit enables the processor to make comparison like =, <, > and logical decisions like AND, OR, NOT.
- The arithmetic logic unit carries out communication with peripheral devices.
- It also carries out bit shifting operation.

Register:

Registers are located on the CPU, and used temporarily for storing data. Because the registers are close to the ALU, they are made out of fast memory, efficiently speeding up calculations.

Registers store data fetched from Immediate Access Store i.e. main memory.

Immediate Access Store (i.e. main memory) holds data and instructions when they are waiting to be processed.

Register Holds data or instructions temporarily when they are being processed.

There are 16 registers. Some examples are

- Program Counter (PC)** - an incrementing counter that keeps track of the **next memory address** of the instruction that is to be executed once the execution of the current instruction is completed.
- Memory Address Register (MAR)** - the address in main memory that is currently being read or written

- c) **Memory Buffer/Data Register (MBR/MBR)** - a two-way register that holds data fetched from memory (and ready for the CPU to process) or data waiting to be stored in memory
- d) **Current Instruction register (CIR)** - a temporary holding ground for the instruction that has just been fetched from memory
- e) **Accumulator Register (ACC)** is used for storing data for ALU to process and the results those are produced by the ALU.

Buses: "The set of wires used to travel signals to and from CPU and different components of computer is called Bus."

Bus is a group of parallel wires that is used as a communication path. As a wire transmits a single bit so 8-bits bus can transfer 8 bits (1 byte) at a time and 16-bits bus can transfer 16 bits (2 bytes) and so on. There are three types of buses according to three types of signals, these are:

- a) **Data Bus:** "The buses which are used to transmit data between CPU, memory and peripherals are called Data Bus."
- b) **Address Bus:** "The buses which are connecting the CPU with main memory and used to identify particular locations (address) in main memory where data is stored are called Address Buses."
- c) **Control Bus:** The wires which are used to transmit the control signals (instructions) generated by Control Unit to the relevant component of the computer.

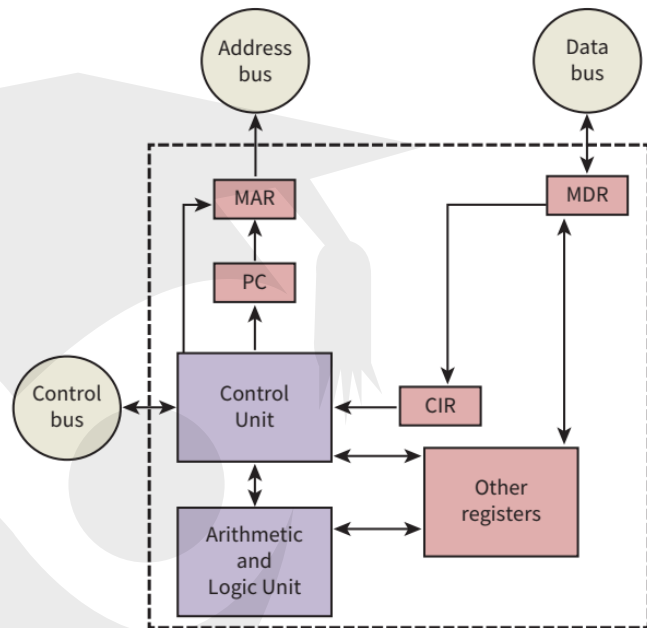

Example Question

Q 1 (a) One of the key features of von Neumann computer architecture is the use of buses. Three buses and three descriptions are shown below. Draw a line to connect each bus to its correct description.

Address bus	This bus carries signals used to coordinate the computer's activities
Control bus	This bi-directional bus is used to exchange data between processor, memory and input/ output devices
Data bus	This uni-directional bus carries signals relating to memory addresses between processor and memory

Q 2)

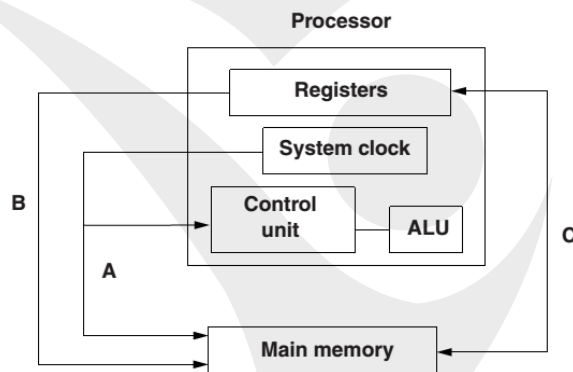

The diagram above shows a simplified form of processor architecture. Name the three buses labelled A, B and C.

- A
- B
- C [3]

Fetch-Execute Cycle:

At its core, all the computer ever does is, execute one instruction in memory after another, over and over. Although there are many different possible (assembly language) instructions that the computer can execute, the basic steps involved in executing an instruction are always the same, and they are called the instruction cycle.

1. **Fetch** the instruction (transfer the instruction from main memory to the decoder)
2. **Decode** the instruction (from machine language)
3. **Execute** the instruction (e.g., add, divide, load, store...)
4. **Store** the result (for instructions like ADD, place the 'answer' in the specified register.)

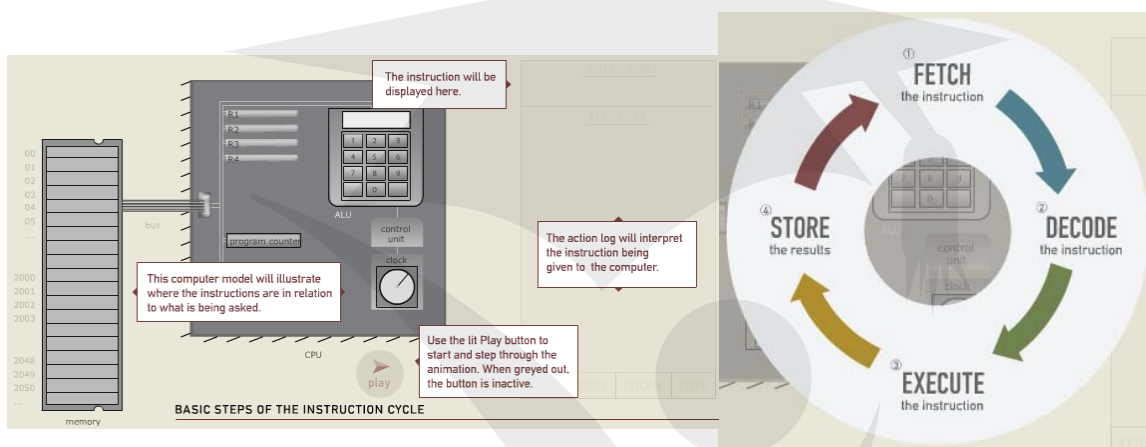

The control unit guides the computer's components through this cycle to execute one instruction. When that instruction is done, the cycle starts all over again with the next instruction.

Registers/circuits involved

The circuits used in the CPU during the cycle are:

- **Program Counter (PC)** - an incrementing counter that keeps track of the **next memory address** of the instruction that is to be executed once the execution of the current instruction is completed.
- **Memory Address Register (MAR)** - the address in main memory that is currently being read or written
- **Memory Buffer Register (MBR)** - a two-way register that holds data fetched from memory (and ready for the CPU to process) or data waiting to be stored in memory
- **Current Instruction register (CIR)** - a temporary holding ground for the instruction that has just been fetched from memory
- **Accumulator Register (ACC)** is used for storing data for ALU to process and the results those are produced by the ALU.

- **Control Unit (CU)** - decodes the program instruction in the CIR, selecting machine resources such as a data source register and a particular arithmetic operation, and coordinates activation of those resources
- **Arithmetic logic unit (ALU)** - performs mathematical and logical operations

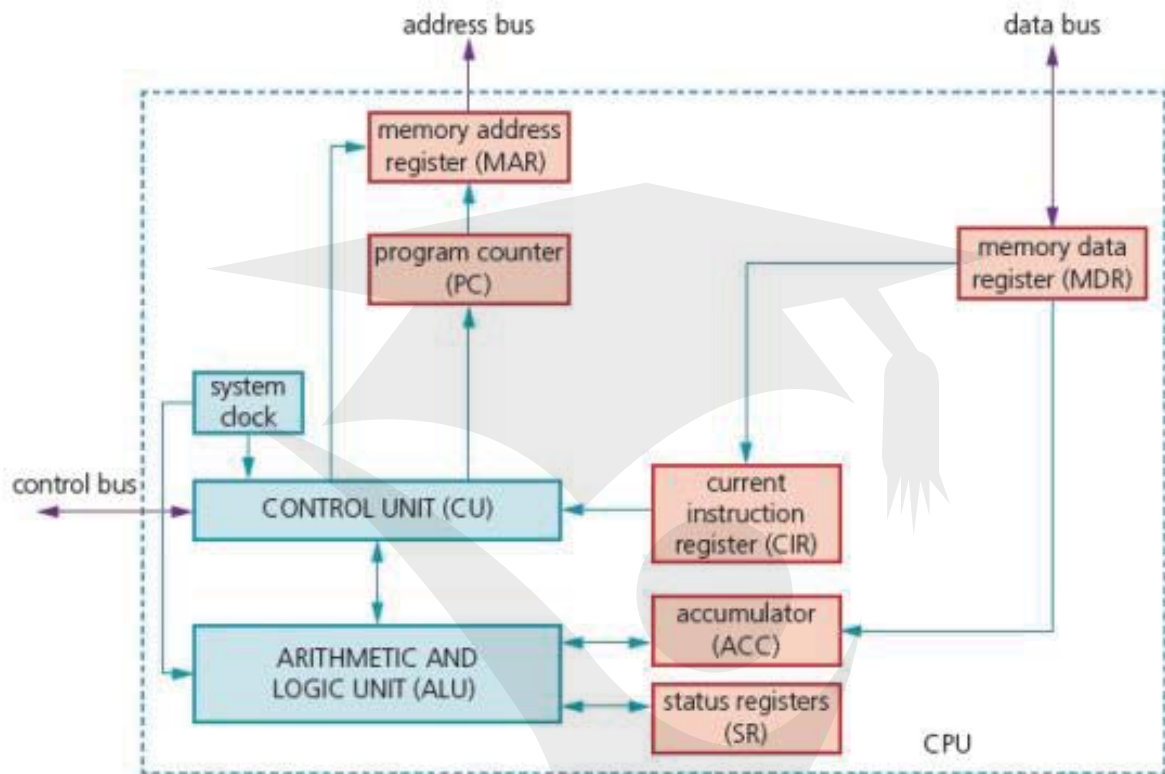

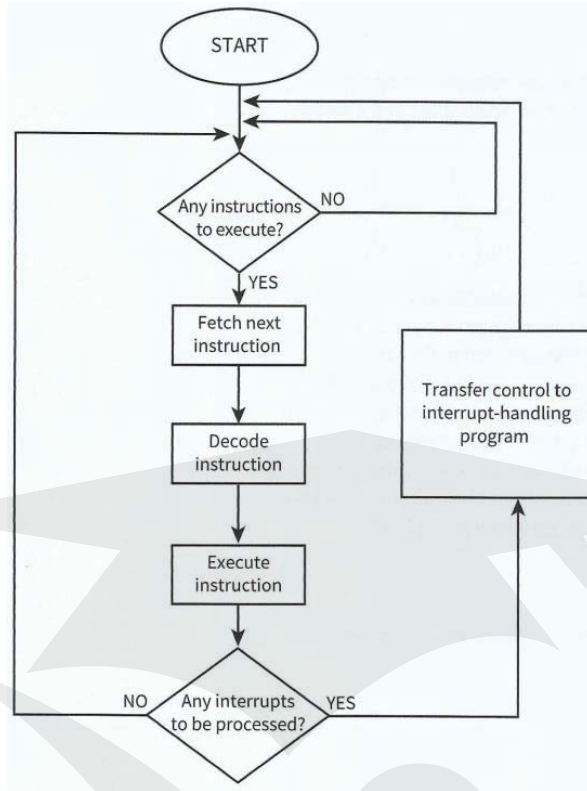

Flow of data and instructions during fetch execute cycle

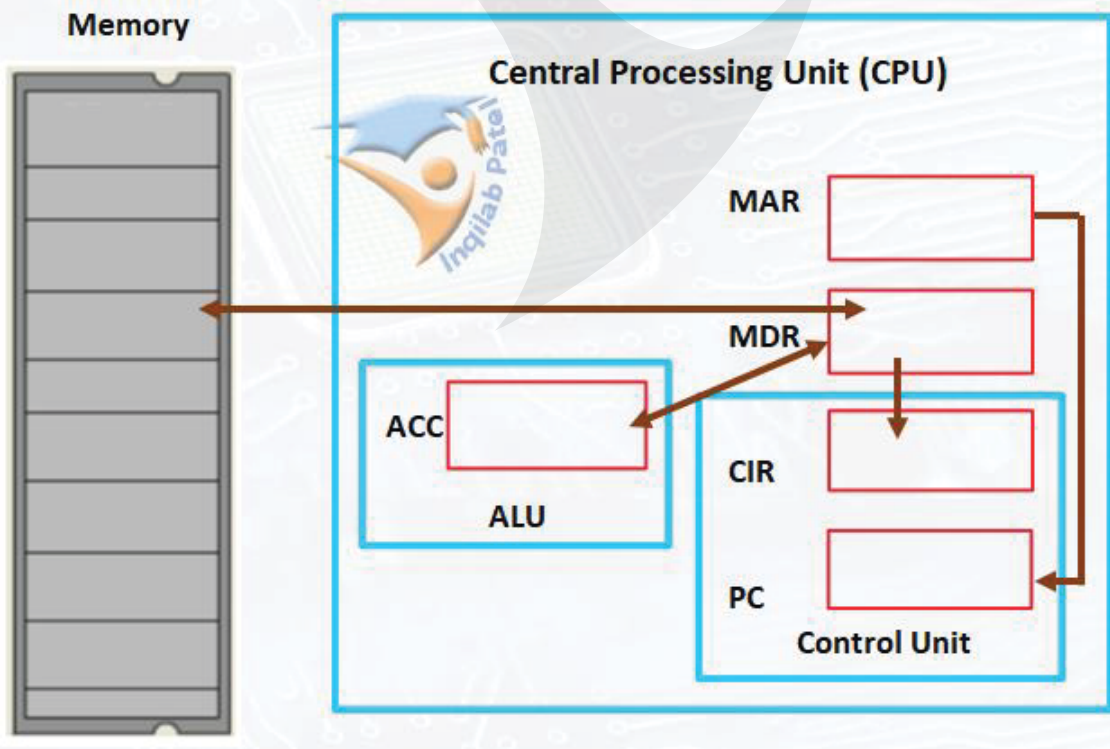

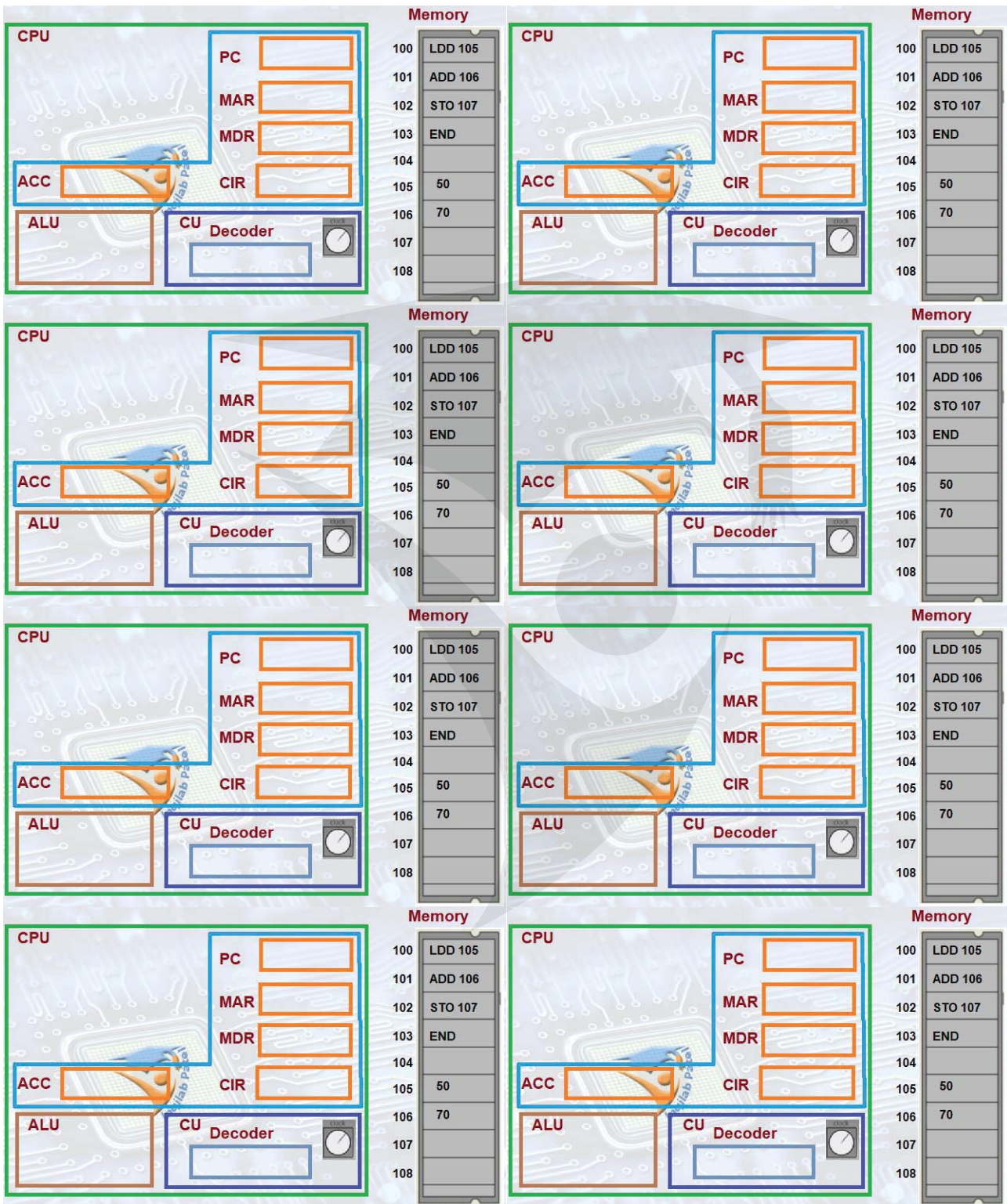

Register Transfer Notation

To describe the cycle we can use register notation. This is a very simple way of noting all the steps involved. In all cases brackets e.g. [PC], means that the contents of the thing inside the brackets are loaded. In the case of the first line, the contents of the program counter are loaded into the Memory Address Register.

MAR ← [PC]

MBR ← [Memory] ; PC ← [PC] + 1 (Increment the PC for next cycle at the same time)

CIR ← [MBR]

CIR sends instruction to Decoder of control unit

Decoder decodes

Or ACC ← [MBR]

ACC sends data to ALU

ALU executes

Q 5a) Complete the following diagrams showing each step of the fetch decode execute cycle:

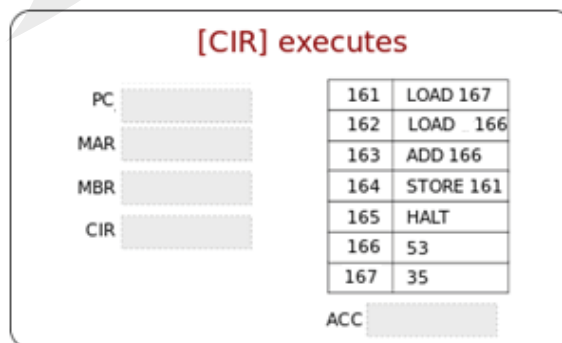
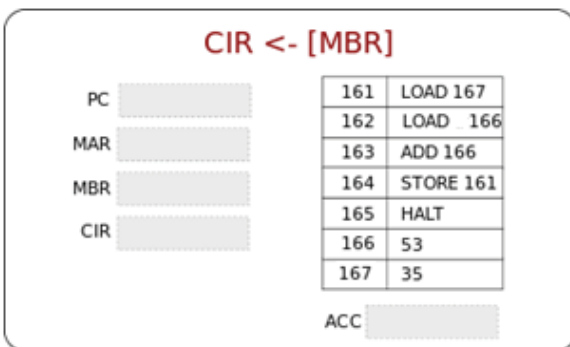
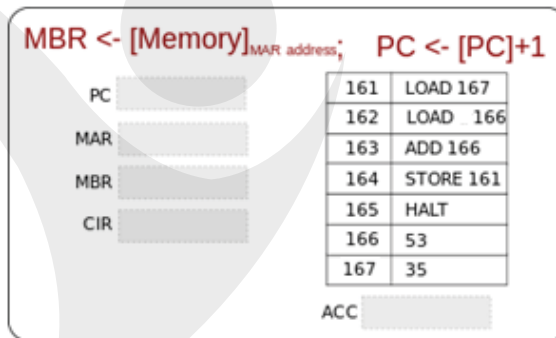
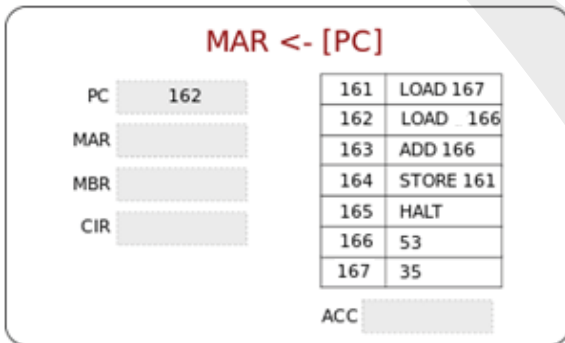

114 | Page

b) The fetch-execute cycle is shown in register transfer notation.

- 01 MAR ← [PC]
- 02 PC ← [PC] - 1
- 03 MDR ← [MAR]
- 04 CIR ← [MAR]

There are **three** errors in the fetch-execute cycle shown.

Identify the line number of each error and give the correction.

Line number

Correction

Line number

Correction

Line number

Correction [3]

Q 6) The contents of some special-purpose registers change as the program is executed.

Complete the trace table for the fetching of the **first program instruction (867A)**:

- Show how the contents of the registers change.
- Put a tick in the address bus and/or data bus column to show when there is a signal change on each bus. [5]

Fetch stage	Special purpose registers (Contents shown in hex)				Buses	
	PC	MAR	MDR	CIR	Address bus	Data bus
	58					
MAR ← [PC]						
PC ← [PC] + 1						
MDR ← [[MAR]]						
CIR ← [MDR]						

Q 8) The sequence of operations shows, in register transfer notation, the fetch stage of the fetch-execute cycle.

- 1 $MAR \leftarrow [PC]$
- 2 $PC \leftarrow [PC] + 1$
- 3 $MDR \leftarrow [[MAR]]$
- 4 $CIR \leftarrow [MDR]$

- [register] denotes contents of the specified register or memory location
- step 1 above is read as “the contents of the Program Counter are copied to the Memory Address Register”

(i) Describe what is happening at step 2.

..... [1]

(ii) Describe what is happening at step 3.

..... [1]

(iii) Describe what is happening at step 4.

..... [1]

Q 9) The following text includes a description of four stages of the fetch-execute cycle. Use the terms below to complete the text:

Memory Data Register (MDR), Memory Address Register (MAR), Program Counter (PC), Current Instruction Register(CIR), address, data bus, main memory, address bus.

The program instructions are stored in a continuous block of

The Program Counter stores the of the next instruction to be fetched.

Stage 1: The contents of the Program Counter are copied to the

Stage 2: The contents of the are then incremented.

Stage 3: The value in the Memory Address Register is loaded to the..... The data value found at this address is loaded on to the..... and copied to the

Stage 4: The contents of the Memory Data Register are copied to the..... and. The instruction can now be decoded and executed. [6]

Candidate Example response

Question 3

Example Candidate Response – high	Examiner Comments
<p>3 Vanessa writes a paragraph as an answer to an examination question about the central processing unit (CPU).</p> <p>Use the list given to complete Vanessa's answer by inserting the correct six missing terms. Not all terms will be used.</p> <ul style="list-style-type: none"> • Components • Data • Decoded • Executed • Fetched • Instructions • RAM • ROM • Secondary storage <p>The CPU processes <u>data</u> and <u>instructions</u></p> <p>An instruction is <u> fetched </u> from <u> RAM </u></p> <p>into the CPU where it is then <u> decoded </u> Once this has taken place the instruction is then <u> executed </u> 1</p> <p style="text-align: right;">[6]</p>	<p>1 The candidate provides six correct terms, in the correct places.</p> <p>Total mark awarded = 6 out of 6</p>

How the candidate could have improved their answer

The candidate provided a fully correct answer that could not have been improved.

Example Candidate Response – middle	Examiner Comments
<p>3 Vanessa writes a paragraph as an answer to an examination question about the central processing unit (CPU).</p> <p>Use the list given to complete Vanessa's answer by inserting the correct six missing terms. Not all terms will be used.</p> <ul style="list-style-type: none"> • Components • Data • Decoded • Executed • Fetched • Instructions • RAM • ROM • Secondary storage <p>The CPU processes <u> instructions </u> and <u> data </u></p> <p>An instruction is <u> fetched </u> from <u> RAM secondary storage </u> 1</p> <p>into the CPU where it is then <u> decoded </u> Once this has taken place the instruction is then <u> executed </u></p> <p style="text-align: right;">[6]</p>	<p>1 The candidate provides an incorrect type of storage that is accessed by the CPU. The CPU cannot access secondary storage to fetch instructions and data. The candidate may misunderstand, as the secondary storage will be where the data is originally stored.</p> <p>Total mark awarded = 5 out of 6</p>

How the candidate could have improved their answer

The candidate demonstrated a good understanding of the central processing unit. However, it would have been beneficial if they had understood that the CPU would fetch instructions and data from the RAM and not secondary storage.

Example Candidate Response – low	Examiner Comments
<p>3 Vanessa writes a paragraph as an answer to an examination question about the central processing unit (CPU).</p> <p>Use the list given to complete Vanessa's answer by inserting the correct six missing terms. Not all terms will be used.</p> <ul style="list-style-type: none"> • Components • Data • Decoded • Executed • Fetched • Instructions • RAM • ROM • Secondary storage <p>The CPU processes <u>RAM</u> and <u>ROM</u> 1</p> <p>An instruction is <u>Fetched</u> from <u>Secondary Storage</u> 2</p> <p>into the CPU where it is then <u>Decoded</u> Once this has taken place the instruction is then <u>Executed</u> 6</p>	<p>1 The candidate shows misunderstanding of what the CPU processes. They provide two components from the computer, rather than items such as data and instructions.</p> <p>2 The candidate also misunderstands that the CPU is able to fetch data from secondary storage. It would be beneficial for the candidate to understand that the CPU can only access the RAM.</p> <p>Total mark awarded = 3 out of 6</p>

How the candidate could have improved their answer

The candidate misunderstood the CPU although they understood that it had a cycle that fetched, decoded and executed. They misunderstood what the CPU processed. They also showed the same misunderstanding that the CPU fetched data from secondary storage.

Common mistakes candidates made in this question

Some candidates misunderstood that the CPU fetched data and instructions from secondary storage. They may have thought this, as the data may originally have been stored in the secondary storage, however, it would have been beneficial for candidates to have understood that the data needed to be brought into RAM, before it could be accessed by the CPU.

Topical Questions from Past Papers

Q 10) 18c Summer 21 P13

10 Several components are involved in processing an instruction in a Von Neumann model for a computer system.

Three of these components are the arithmetic logic unit (ALU), control unit (CU) and random access memory (RAM).

(a) Six statements are given about the components.

Tick (✓) to show if each statement applies to the ALU, CU or the RAM. Some statements may apply to more than one component. [6]

Statement	ALU (✓)	CU (✓)	RAM (✓)
stores data and instructions before they enter the central processing unit (CPU)			
contains a register called the accumulator			
manages the transmission of data and instructions to the correct components			
contained within the CPU			
uses the data bus to send data into or out of the CPU			
carries out calculations on data			

(b) The accumulator is a register that is part of the Von Neumann model.

Give two other registers that are part of the Von Neumann model.

1

2 [2]

10(a)	One mark per each correct row			6	
	Statement	ALU (✓)	CU (✓)		RAM (✓)
	Stores data and instructions before they enter the central processing unit (CPU)				✓
	Contains a register called the accumulator	✓			
	Manages the transmission of data and instructions to the correct components		✓		
	Contained within the CPU	✓	✓		
	Uses the data bus to send data into or out of the CPU	(✓)			✓
Carries out calculations on data	✓				
10(b)	Any two from: - MAR - MDR // MBR - PC - CIR // IR			2	

Q 11) Winter 20 P13) 2 Paige has a computer that has a central processing unit (CPU) based on the Von Neumann model for a computer system.

- (a)** Identify the component within the CPU that controls the flow of data.
 [1]
- (b)** Identify the component within the CPU where calculations are carried out.
 [1]
- (c)** Identify the component within the CPU that stores the address of the next instruction to be processed.
 [1]
- (d)** Identify the register within the CPU that holds an instruction that has been fetched from memory.
 [1]
- (e)** Identify the register within the CPU that holds data that has been fetched from memory.
 [1]

121 | Page

Q 12) Summer 2015 P11

7 (a) One of the key features of von Neumann computer architecture is the use of buses.

Three buses and three descriptions are shown below.

Draw a line to connect each bus to its correct description.

Address bus	This bus carries signals used to coordinate the computer's activities
Control bus	This bi-directional bus is used to exchange data between processor, memory and input/ output devices
Data bus	This uni-directional bus carries signals relating to memory addresses between processor and memory

(b) The seven stages in a von Neumann fetch-execute cycle are shown in the table below. Put each stage in the correct sequence by writing the numbers 1 to 7 in the right hand column. The first one has been done for you.

Stage	Sequence number
the instruction is then copied from the memory location contained in the MAR (memory address register) and is placed in the MDR (memory data register)	
the instruction is finally decoded and is then executed	
the PC (program counter) contains the address of the next instruction to be fetched	1
the entire instruction is then copied from the MDR (memory data register) and placed in the CIR (current instruction register)	
the address contained in the PC (program counter) is copied to the MAR (memory address register) via the address bus	
the address part of the instruction, if any, is placed in the MAR (memory address register)	
the value in the PC (program counter) is then incremented so that it points to the next instruction to be fetched	

Q 13) March 21 P12

8 (c) Computers based on the Von Neumann model, for a computer system, use interrupts.

Explain why interrupts are needed.

.....

.....

.....

.....

[2]

Q 14) Winter 2015 P13

3 A section of computer memory is shown below:

Address	Content
1000 0000	0110 1110
1000 0001	0101 0001
1000 0010	1000 1101
1000 0011	1000 1100
1000 1100	
1000 1101	
1000 1110	
1000 1111	

(a) (i) The contents of memory location 1000 0001 are to be read.

Show the contents of the Memory Address Register (MAR) and the Memory Data Register (MDR) during this read operation: [2]

MAR

--	--	--	--	--	--	--	--

MDR

--	--	--	--	--	--	--	--

(ii) The value 0111 1001 is to be written into memory location 1000 1110.

Show the contents of the MAR and MDR during this write operation: [2]

MAR

--	--	--	--	--	--	--	--

MDR

--	--	--	--	--	--	--	--

(iii) Show any changes to the computer memory following the read and write operations in part (a)(i) and part (a)(ii). [1]

Address	Content
1000 0000	0110 1110
1000 0001	0101 0001
1000 0010	1000 1101
1000 0011	1000 1100
1000 1100	
1000 1101	
1000 1110	
1000 1111	

(b) Name **three** other registers used in computers.

- 1
- 2
- 3 [3]

(c) The control unit is part of a computer system.

What is the function of the control unit?

.....

 [3]

Q 15) Winter 2016 P11& 13

1 To process an instruction, a central processing unit (CPU) goes through a cycle that has three main stages.

Name each stage in this cycle.

- Stage 1
- Stage 2
- Stage 3 [3]

Q 16) Winter 2016 P12

6 Four computer terms and **eight** descriptions are shown below.

Draw lines to connect each computer term to the correct description(s).

[4]

Computer term	Description
Arithmetic and logic unit (ALU)	Data can be read but not altered
Control unit	Carries out operations such as addition and multiplication
	Stores bootstrap loader and BIOS
Random access memory (RAM)	Fetches each instruction in turn
	Carries out operations such as AND, OR, NOT
	Stores part of the operating system currently in use
Read only memory (ROM)	Stores data currently in use
	Manages execution of each instruction

Q 17) Summer 2017 P12

1 Name **three** different buses that are used in the fetch-execute cycle.

Bus 1

Bus 2

Bus 3 [3]

Examiner Comment on Q 1

Many candidates provided three correct busses. The most common incorrect answer was candidates providing fetch, decode and execute, which demonstrated a misunderstanding of the question.

Q 18) Winter 2017 P13

4 Six components of a computer system and six descriptions are shown.

Draw a line to match each component with the most suitable description.

[5]

Component	Description
Arithmetic Logic Unit (ALU)	Used to connect together the internal components of the CPU.
Buses	Used to carry out calculations on data.
Control Unit(CU)	Used to temporarily hold data and instructions during processing.
Immediate Access Store (IAS)	Used to allow interaction with the computer.
Input/ Output	Used to hold data and instructions before they are processed.
Registers	Used to manage the flow of data through the CPU.

Q 19) March 2018 P12 (India)

10 The table shows a segment of primary memory from a Von Neumann model computer.

Address	Contents
10001	11001101
10010	11110001
10011	10101111
10100	10000110
10101	00011001
10110	10101100

The program counter contains the data 10010.

(a) (i) State the data that will be placed in the memory address register (MAR).

.....[1]

(ii) State the data that will be placed in the memory data register (MDR).

.....[1]

(b) Describe the stored program concept when applied to the Von Neumann model.

.....
.....
.....
.....
.....
.....
.....
.....
.....
.....
.....[4]

Q 20) Summer 2018 P11 Six components of the Von Neumann model for a computer system and **six** descriptions are given. Draw a line to match each component to the most suitable description. [5]

Component	Description
Immediate access store(IAS)	Holds data and instructions when they are loaded from main memory and are waiting to be processed.
Register	Holds data temporarily that is currently being used in a calculation.
Control unit(CU)	Holds data or instructions temporarily when they are being processed.
Accumulator(ACC)	Manages the flow of data and interaction between the components of the processor.
Arithmetic logic unit (ALU)	Carries out the calculations on data.
Bus	Pathway for transmitting data and instructions.

Q 21) Summer 2018 P12

6 Kelvin correctly answers an examination question about the Von Neumann model.

Eight different terms have been removed from his answer.

Complete the sentences in Kelvin's answer, using the list given. Not all items in the list need to be used.

- accumulator (ACC)
- address bus
- arithmetic logic unit (ALU)
- control unit (CU)
- data bus
- executed
- fetches
- immediate access store (IAS)
- memory address register (MAR)
- saved
- memory data register (MDR)
- program counter (PC)
- transmits

The central processing unit (CPU)the data and instructions needed and stores them in the..... to wait to be processed. The holds the address of the next instruction. This address is sent to the

..... The data from this address is sent to the

The instruction can then be decoded andAny calculations that are carried out on the data are done by the

..... During calculations, the data is temporarily held in a register called the[8]

Q 22) Winter 2018 P13

11 The fetch-execute cycle make use of registers.

(a) Describe the role of the Program Counter (PC).

.....
.....
.....
..... [2]

(b) Describe the role of the Memory Data Register (MDR).

.....
.....
.....
..... [2]

Q 23) Summer 2019 P12

3 Vanessa writes a paragraph as an answer to an examination question about the central processing unit (CPU). Use the list given to complete Vanessa's answer by inserting the correct **six** missing terms. Not all terms will be used.

- Components • Data • Decoded • Executed • Fetched
- Instructions • RAM • ROM • Secondary storage

The CPU processes and
An instruction is from into the CPU where it is then Once this has taken place the instruction is then [6]

Q 24) Winter 2019 P13

7 The Von Neumann model for a computer system has several components that are used in the fetch-execute cycle. (a) One component is main memory.

(i) Describe what is meant by main memory and how it is used in the Von Neumann model for a computer system.

.....
.....
.....
..... [3]

(ii) State **two** other components in the Von Neumann model for a computer system.

- 1
- 2 [2]

(b) Computer systems often use interrupts. Tick (✓) to show if each statement is **True** or **False**. [5]

Statement	True (✓)	False (✓)
Interrupts can be hardware based or software based		
Interrupts are handled by the operating system		
Interrupts allow a computer to multitask		
Interrupts work out which program to give priority to		
Interrupts are vital to a computer and it cannot function without them		

Q 25) Winter 2019 P12) 2 The Von Neumann model for a computer system uses several components in the fetch-execute cycle. One component that is used is the Control Unit (CU). Identify **four** other components that are used in the Von Neumann model for a computer system.

- 1
- 2
- 3
- 4 [4]

Q 26) Summer 20 P12

1 (b) (ii) Identify the component of the CPU that is responsible for decoding instructions. [1]

Q 27) 15a Summer 20 P11 5 Six components of a computer are given.

Some are part of the central processing unit (CPU) of the Von Neumann model for a computer system.

Tick (✓) to show if each component is a **CPU component** or is **Not a CPU component**. [6]

Component	CPU component (✓)	Not a CPU component (✓)
Arithmetic logic unit (ALU)		
Hard disk drive (HDD)		
Memory address register (MAR)		
Random access memory (RAM)		
Solid state drive (SSD)		
Control unit (CU)		

1.3.3 & 1.3.4 Input & Output Devices

Input

Output



Learning Outcome	To Read	Have Read	To Revise	Have	Prepared
1.3.3: Input devices					
Describe the principles of operation (how each device works) of these input devices: 2D and 3D scanners, barcode readers, Quick Response (QR) code readers, digital cameras, keyboards, mice, touch screens, interactive whiteboard, microphones					
Describe how these principles are applied to real-life scenarios, for example: scanning of passports at airports, barcode readers at supermarket checkouts, and touch screens on mobile devices					
Describe how a range of sensors can be used to input data into a computer system, including light, temperature, magnetic field, gas, pressure, moisture, humidity, ph and motion					
Describe how these sensors are used in real-life scenarios, for example: street lights, security devices, pollution control, games, and household and industrial applications					
1.3.4: Output devices					
Describe the principles of operation of a range of output devices, including: inkjet, laser and 3D printers; 2D and 3D cutters; speakers and headphones; actuators; flat-panel display screens, including Liquid Crystal Display (LCD) and Light-Emitting Diodes (LED); and LCD projectors and Digital Light Projectors (DLP)					
Describe how these principles are applied to real-life scenarios, for example: printing single items on demand or in large volumes; use of small screens on mobile devices					

Input Devices:

Input devices allow us to enter raw data into a computer. The computer processes the data and then produces outputs that we can understand using an output device. Input devices can be manual or automatic.

Two-dimensional scanners

2D scanners are input devices used to make digital copies of documents or pictures, but can also be used to create a 2D image of other objects as well.

How 2D Scanner works:

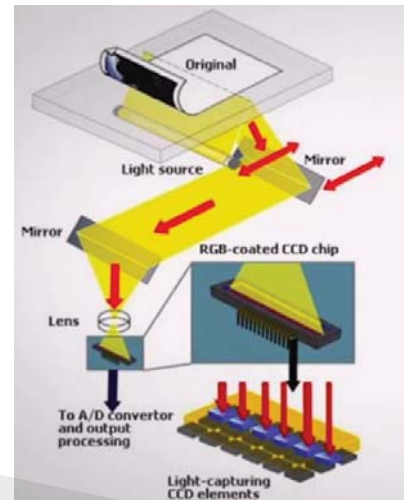

1	Cover is raised
2	Document is placed in on glass panel and cover is closed
3	A bright light illuminates the documents lamp like xenon which produce very bright white light
4	A scan head moves across the document. An image is produced.
5	The image is sent to a lens using series of mirrors. The lens focuses the document image.
6	The focused image fall onto a charge couple device (CCD) which consists of number of ICs
7	CCD is made up of light-sensitive elements (pixels) . Each element of CCD creates an electric charge when light falls on it and the scanned image is converted into digital form .
8	Software produces digital image from electronic form

How 3D Scanner works:

- Scanners shines a laser (or light) over the surface of a 3D object
- Records measurements of the geometry/dimensions of the object
- Measurements are converted to digital file
- Produces a 3D digital

Bar Code Reader/Scanner

How it works

Stage	Description
1	The barcode is first read by a red laser or red LED (LIGHT EMITTING DIODE) .
2	Light is reflected back off the barcode; the dark areas reflect little or no light which allows the bars to be read.
3	The reflected light is read by sensors (photoelectric cells).
4	As the laser or LED light is scanned across the barcode, a pattern is generated which is converted into digital data – this allows the computer to understand the barcode.
5	For example: the digit '3' on the left generates the pattern L D DDD L D (where L = light and D = dark); this has the binary equivalent of 0 1 1 1 1 0 1 (where L = 0 and D = 1)
6	If barcode are not scanned correctly the bar code number is types in manually using keyboard

When barcode has been read, then what happens?

- The barcode number is looked up in the stock database (the barcode is known as the **KEY FIELD** in the stock item record); this key field uniquely identifies each stock item.
- When the barcode number is found, the stock item record is looked up.
- The price and other stock item details are sent back to the checkout (or **POINT OF SALE TERMINAL (POS)**).
- The number of stock items in the record is reduced by one each time the barcode is read.
- This new value for number of stock items is written back to the stock item record.
- The number of stock items is compared to the re-order level; if it is less than or equal to this value, more stock items are *automatically* ordered.
- Once an order for more stock items is generated, a flag is added to the record to stop re-ordering every time the stock item barcode is read.
- When new stock items arrive, the stock levels are updated in the database.

The following flowchart shows how barcodes are used at the point of sale in an automatic stock control system.

Quick response (QR) codes

QR code (abbreviated from Quick Response Code) is the trademark for a type of matrix barcode (or two-dimensional barcode).

Structure

A QR code consists of black squares arranged in a square grid on a white background.

1. The position detection pattern consists of three identical structures that are located in all corners of the QR Code except the bottom right corner.
2. Alignment marker supports the decoder software in compensating for moderate image distortions.
3. Data area has data, converted into a bit stream and then stored in 8 bit parts (called code words).

How it Works

- Camera on smart phones are used to Read/scan QR codes using **app**
- The **camera** is used to scan/capture the image of QR code
- Position direction pattern and alignment marker are used to define the alignment
- Black squares reflect less light while white squares reflect more light
- The app on mobile device processes the image
- Each small square/pixel is converted to a binary value



The following QR Code at left stores web address <http://www.inqilabpatel.com> while QR Code at right stores contact information of Inqilab Patel

Applications

Applications include product tracking, item identification, time tracking, document management, and general marketing.

Keyboard

The keyboard is the piece of computer hardware used to input text, characters, and other commands into a computer or similar device.

How it works

S No	Step
1.	Uses switches and circuits to translate keystrokes into signals the computer can understand
2.	The key matrix is a grid of circuits / three layers of plastic underneath the keys
3.	Each circuit is broken beneath the key / middle layer contains holes
4.	When key pressed, a circuit is made / completed and a signal is sent
5.	Processor compares location of signal from key matrix to a character map stored on ROM
6.	A character code for each key press is saved in a keyboard buffer

Each individual key is a switch. When a key is pressed it generates a specific binary code, based on ASCII. For example:

- Pressing **A** key produces binary code 01100001, representing lower case letter **a**,
- This binary code is sent to processor.

So processor recognises which key is pressed

Drawback:

Keyboard is the easiest way to enter text into a computer but it has some drawbacks too, for example:

- It is a relatively slow method of data entry.
- It is prone to errors.
- Frequent use of it can lead to injuries, such as **REPETITIVE STRAIN INJURY(RSI)** in the hands and wrists.

Ergonomic keyboards are designed to give more support to the wrists and hands when doing a lot of typing.

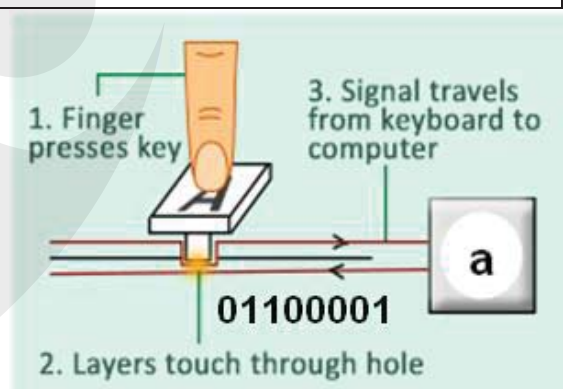

Mouse:

A **computer mouse** is a handheld hardware input device that controls a cursor in a GUI and can move and select text, icons, files, and folders.

The more traditional type with a mechanical ball arrangement; connected to the computer through a USB port while the more modern type (optical mouse) that use red LEDs to detect movement in the x-y direction.

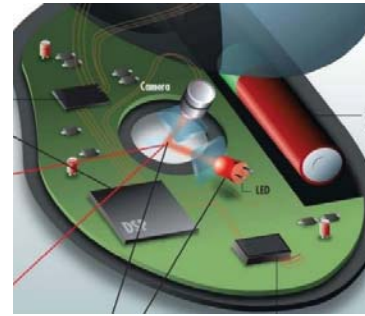
**How optical mouse works:**

S No	Step
1	laser/light shines onto a surface through a (polished) ring at the base
2	the light is reflected from the surface through the ring
3	sensor detects reflected light
4	capturing details/photograph of surface (under the ring) at about 1500 times per second
5	as the mouse moves the sensor detects changes in the surface detail/photograph
6	These changes are translated into movement (change of x and y co-ordinates)
7	the computer/software updates the position of the cursor on the screen

Digital camera

A digital camera is an input device that captures images (and sometimes video) digitally. Digital cameras use an image sensor chip to capture the image, rather than the film used by a traditional camera.

Benefits over traditional camera

- Digital cameras produce photographs for transfer to a computer directly or to print out by connecting directly to a printer.
- Many digital cameras also allow short video clips to be produced.
- Photographs can be uploaded directly into applications software such as word processors, desktop publishers, etc.
- Modern digital cameras simply link to a computer system via a USB port or by using Bluetooth (which enables wireless transfer of photographic files).

How digital camera works

Digital camera uses microprocessor, lenses, pixels and storage. The photograph is captured when light passes through the lens onto a light sensitive cell. This cell is made up of tiny elements known as pixels. The number of pixels determines the size of the file used to store the photograph (e.g. a 14- megapixel camera will need 42 megabytes to store each raw photograph).

How captured images are converted into digital photo files

- Captured image is sent to DAC to convert it from analogue to digital (using ADC)
- Image is turned into pixels
- Each pixel is given a binary value
- Pixels form a grid (to create the image)
- Each pixel has a colour
- Pixels are stored in sequence (in a file)
- Meta data is stored (to describe the dimensions/resolution of the image), it stores the dimensions/colour depth .etc.
- For example JPEG

Role of microprocessor

Microprocessor can automatically carry out the following tasks:

- adjust the shutter speed
- focus the image automatically
- operate the flash automatically
- adjust the aperture size
- adjust the size of the image
- remove 'red eye' when the flash has been used

Factors effecting quality of photographs

The quality of the photograph also depends on many other factors, such as:

- the type of lens used
- the lighting

Mobile phone using digital camera

Mobile phones have caught up with digital cameras as regards number of pixels.

Drawback of camera in mobile phone

Mobile phones usually have poor lens quality and limited memory for the storage of photos.

Microphone:

A microphone is an input device used to enter sound into a computer.

The sound can be used for

- Voice over for a presentation
- Voice recognition for security system
- Speech recognition for speech-to-text software
- For disabled person.

How to capture sound:

To record a sound microphone is used.

Microphone has a diaphragm. Diaphragm is attached with a moveable coil. Inside this movable coil there is fixed magnet.

When sound waves strike diaphragm, causes vibration in it and the movable coil starts moving to and fro around fixed magnet. This movement generates electrical signals. And in this way sound is captured.

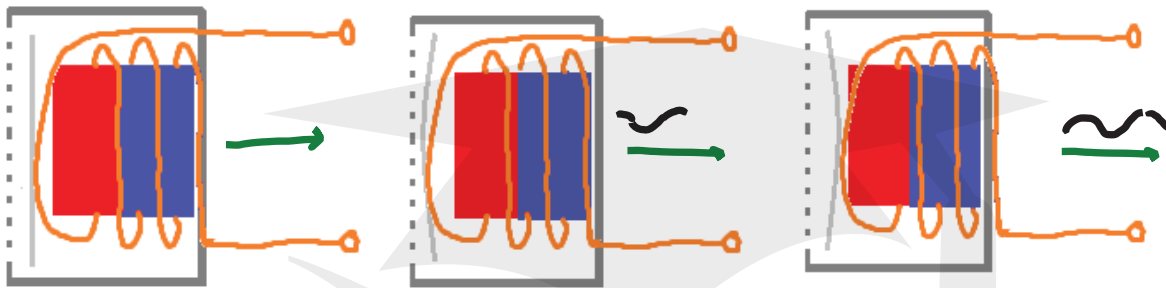

Conversion of Analogue Sound into Digital Format.

Sound waves are analogue values, these analogue values are converted into digital values to manipulate and to store in computer.

ADC (Analogue to Digital Converter) is used to convert analogue sound waves into digital values. This conversion is done in following steps.

Firstly, a filter removes non-audible sound waves. Humans can hear **sounds** in a **frequency range** from about 20 Hz to 20 kHz.

Then sound waves are sampled at a given time rate (Sound waves are broken down thousands of smaller parts (samples) per second.)

The height/amplitude of each sound wave is determined.

Approximation is used when necessary.

At last sound wave values are stored in binary digits, depending upon number of bits per sample.

Voice Recognition	Speech Recognition
In voice recognition system, the user's voice is detected and then converted into digital.	In Speech Recognition the spoken words are recognised and shown on a screen, input into a word processor or used in other application.
A few words spoken produce a digital wave pattern. Software compares this wave pattern to wave patterns stored in memory to see if they match. If they match, then the person has been correctly identified.	Speech recognition is language dependent
This technology can be used in security systems.	It is used to give commands by speaking to computer or in speech-to-text software

Touch Sensitive Screens

The majority of mobile phones use touch screens. The majority of mobile phones use touch screens.

Three common technologies are used by different mobile phone manufacturers:

- resistive
- capacitive
- infrared

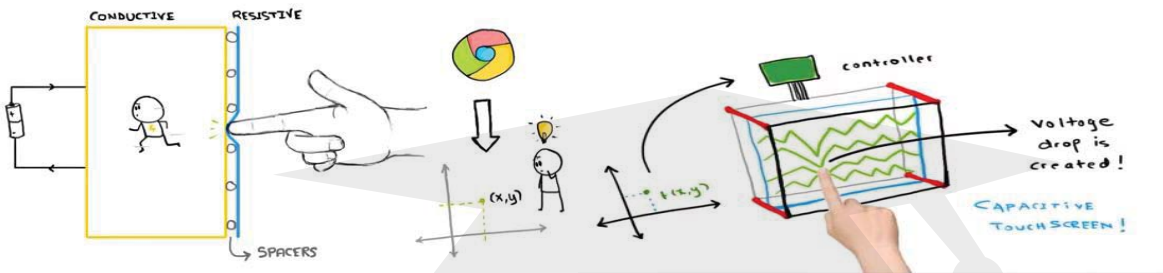
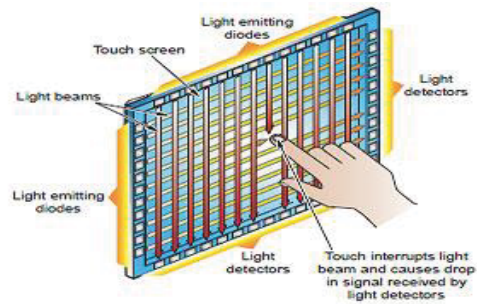

Differences between touch screens

	Resistive	Capacitive	Infra Red
Hardware	The screen of resistive system includes a glass panel covered with a thin metallic layer made of a substance that conducts electricity. Spacers on the layer support a metallic layer that resists the flow of electricity.	In a capacitive system , a transparent material that stores an electrical charge covers the screen's glass panel.	Infrared touch screens are based on light-beam interruption technology. Instead of an overlay on the surface, a frame surrounds the display. The frame has light sources, or light emitting diodes (LEDs) on one side and light detectors on the opposite side, creating an optical grid across the screen.
How it works	When you touch the screen with your finger or a stylus, the two layers make contact, changing the electrical field produced by the layers. This permits the computer to calculate the coordinates of the contact.	<ul style="list-style-type: none"> ➤ The screen has conductive layer ➤ An electrostatic/electric field is created on the screen ➤ Sensor(s) (around the screen) monitor the electrostatic field ➤ When touched (electrostatic) charge is transferred to finger ➤ Location of touch is calculated // Co-ordinates used to calculate touch 	<ul style="list-style-type: none"> ➤ Infrared rays are sent across screen (from the edges) and captured by sensors at the opposite side ➤ Infrared rays form a grid across the screen ➤ Infrared ray is broken when someone touches screen by a finger blocking a beam ➤ This signal is converted into digital by ADC ➤ The digital signal is sent to processor which calculate (on where beam is broken) to locate the 'touch'

	Resistive	Capacitive	Infra Red
			➤ Co-ordinates are used to locate the touch
Finger Touch	can use stylus/ finger/ gloved finger/pen	Can't use gloved finger	can use stylus/ finger/ gloved finger/pen
Visibility in sunlight	poor visibility in sunlight	good visibility in sunlight	Fairly good
Cost	Inexpensive	Medium cost	Expensive
Durability	- vulnerable to scratching - wears through time	Durable	Good durability

Touch screen technologies can be described as resistive or capacitive.

Six statements are given about resistive and capacitive technology.

[6]

Tick (✓) to show if the statement applies to **Resistive** or **Capacitive** and/or **Infrared** technology.

Statement	Resistive (✓)	Capacitive (✓)	Infrared (✓)
This touch screen has multi-touch capabilities			
This touch screen cannot be used whilst wearing gloves			
This touch screen is made up of two layers with a small space in between			
This touch screen uses the electrical properties of the human body			
This touch screen is normally cheaper to manufacture			
This touch screen has a quicker response time			

Example Candidate Response – high	Examiner Comments
<p>10 Remy has a mobile device that has a capacitive touch screen. Describe how the capacitive touch screen registers Remy's touch.</p> <p>There are many layers of glass. There is an electric field on the layers. When the top layer is touched, there is a change in the electric field. The sensors detect the change. Microprocessors calculate where the change occurred and calculate which part of the screen has been touched. [4]</p>	<p>1 The first mark is awarded for the reference to the electric field.</p> <p>2 The second mark is awarded for the reference to the change in the electric field. This is acceptable for an effect of the charge being transferred to the user.</p> <p>3 The third mark is awarded for the sensors use in detecting the change, implying that they read the electric field.</p> <p>4 The fourth mark is awarded for the calculation of the location of the user's touch.</p> <p>Total mark awarded = 4 out of 4</p>

How the candidate could have improved their answer

The candidate could have explained why the electric field changed, stating this was due to the charge being transferred to the user's finger.

Example Candidate Response – middle	Examiner Comments
<p>10 Remy has a mobile device that has a capacitive touch screen. Describe how the capacitive touch screen registers Remy's touch.</p> <p>has many layers made up of glass. electric field/current flows from all 4 sides of the screen. when the screen is touched the electric field/current changes. location of touch is calculated by an on-board microprocessor. [4]</p>	<p>1 The first mark is awarded for stating the electric current flows from the corners of the screen.</p> <p>2 The second mark is awarded for stating the electric field changes as a result of the user's touch.</p> <p>3 The third mark is given for the calculation of the location of the user's touch.</p> <p>Total mark awarded = 3 out of 4</p>

How the candidate could have improved their answer

If the candidate had added how the electric field was read, for example, using sensors, then this would have gained them a further mark.

Example Candidate Response – low	Examiner Comments
<p>10 Remy has a mobile device that has a capacitive touch screen.</p> <p>Describe how the capacitive touch screen registers Remy's touch.</p> <p>In a capacitive touch screen layers of conductive glass are use which conduct electricity. 1 When the screen is touched, an electro-static current is produced. 2 That current is detected by a sensor 3 which then calculates the location of the touch. 4</p> <p>[4]</p>	<p>1 This isn't accurate; an electric field is present on the screen, but the layers don't strictly conduct electricity.</p> <p>2 This isn't correct; the electric field is present at all times, it isn't just produced when the screen is touched.</p> <p>3 The candidate is given the benefit of the doubt and is awarded a mark for the use of a sensor reading the current.</p> <p>4 The candidate refers to the sensor calculating the location of the touch, which is incorrect. The sensor cannot do this.</p> <p>Total mark awarded = 1 out of 4</p>

How the candidate could have improved their answer

The candidate lacked accuracy in their response. In this type of touch screen, an electric field was present on the screen, but the layers did not strictly conduct electricity. The electric field was always present and was not created when a user touched the screen, which was what the candidate had stated. If the candidate had said the current changed, rather than was produced, this would have gained them an additional mark.

Common mistakes candidates made in this question

Candidates often lacked accuracy when they were asked to describe technical processes. Candidates should have made sure that they used the correct terminology and were accurate in their description.

Interactive White Board:

An **interactive whiteboard (IWB)** is a large interactive display in the form factor of a whiteboard. It can either be a standalone touchscreen computer used independently to perform tasks and operations, or a connectable apparatus used as a touchpad to control computers from a projector.

How interactive whiteboard Works

A device driver is usually installed on the attached computer so that the interactive whiteboard can act as a Human Input Device (HID), like a mouse.

The computer's video output is connected to a digital projector so that images may be projected on the interactive whiteboard surface.

The user then calibrates the whiteboard image by matching the position of the projected image in reference to the whiteboard using a pointer as necessary.

After this, the pointer or other device may be used to activate programs, buttons and menus from the whiteboard itself, just as one would ordinarily do with a mouse.

If text input is required, user can invoke an on-screen keyboard or, if the whiteboard software provides for this, utilize handwriting recognition.

Thus, an IWB emulates both a mouse and a keyboard. The user can conduct a presentation or a class almost exclusively from the whiteboard.

In addition, most IWBs are supplied with software that provides tools and features specifically designed to maximize interaction opportunities. These generally include the ability to create virtual versions of paper flipcharts, pen and highlighter options, and possibly even virtual rulers, protractors, and compasses—instruments that would be used in traditional classroom teaching.

Uses for interactive whiteboards may include:

- Running software that is loaded onto the connected PC, such as a web browsers or other software used in the classroom.
- Capturing and saving notes written on a whiteboard to the connected PC
- Capturing notes written on a graphics tablet connected to the whiteboard
- Controlling the PC from the white board using click and drag, mark up which annotates a program or presentation
- Using OCR software to translate cursive writing on a graphics tablet into text
- Using an Audience Response System so that presenters can poll a classroom audience or conduct quizzes, capturing feedback onto the whiteboard



143 | Page

Monitoring System

In monitoring systems microprocessor just examine sensors' reading and report their results.

Control System

A control system is a type of computer system that manages, commands and directs other devices or systems. There are open and closed loop control systems. They usually take an input, process it and get an output.

A control system consists of Sensors, ADC, Processor, DAC and Actuator.

Sensors and **actuators** are devices that are used for automatic input and control in real-time systems.

Sensors is an input device which measures a specific physical quantity (input) and send the data to processor. There are different types of sensors like, heat, infra-red, humidity, pressure, acoustic, gas, bar code etc.

The signals generated by sensors are generally in analogue form and needed to be converted into digital form so as processor can understand it. **ADC (Analogue-to-Digital Converter)** is used to convert these analogue signals into digital signals.

Actuators is a hardware device that receives a signal from a computer and adjusts the setting of a controlling device.

The processor sends digital signals, which are converted into analogue signals using **DAC (Digital-to-Analogue Converter)** so as actuator can act upon it.

Actuator is responsible for powering and moving a motor in machinery, such as a robot arm in a factory.

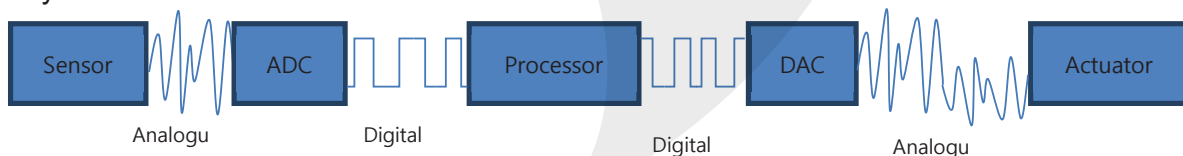

For example in a furnace, a sensor is used to measure temperature in the furnace and it sends readings in analogue form (small electric currents/voltages). This data is converted into digital by an ADC and is fed to a computer, which compares the input temperature with the required temperature stored on a file. If any action is needed (furnace temperature is too low or too high) then a digital signal is sent out from the computer. This signal is converted into an electric current/voltage (i.e. analogue) so that the valve can be regulated (i.e. opened or closed to control the gas supply and hence the furnace temperature).

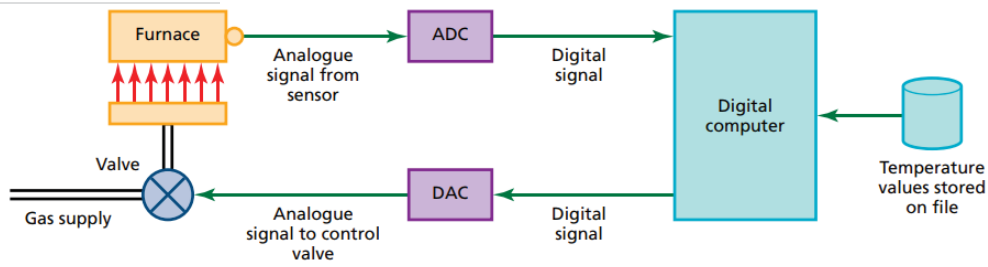

Feedback System

Control systems can be open loop or closed loop.

Open loop Feedback systems will just consider the input and then keep repeating the same task given the input, e.g. a microwave heats for a given time period without actually checking the temperature of the food.

Closed loop Feedback systems on the other hand will also take into account other factors, including the output itself. A furnace is a closed-loop feedback system.

Above furnace system is a closed-loop feedback system. In this system temperature sensor measures temperature in the furnace and it sends readings to processor, which compares the input temperature with the required temperature stored on a file. If any action is needed (furnace temperature is too low or too high) then a digital signal is sent out from the processor. Actuator regulates the valves (i.e. opened or closed to control the gas supply and hence the furnace temperature). Then sensor again measures the temperature which is actually itself the output of the system. On the basis of new readings processor decides new actions. Means new actions depends upon the results of previous actions.

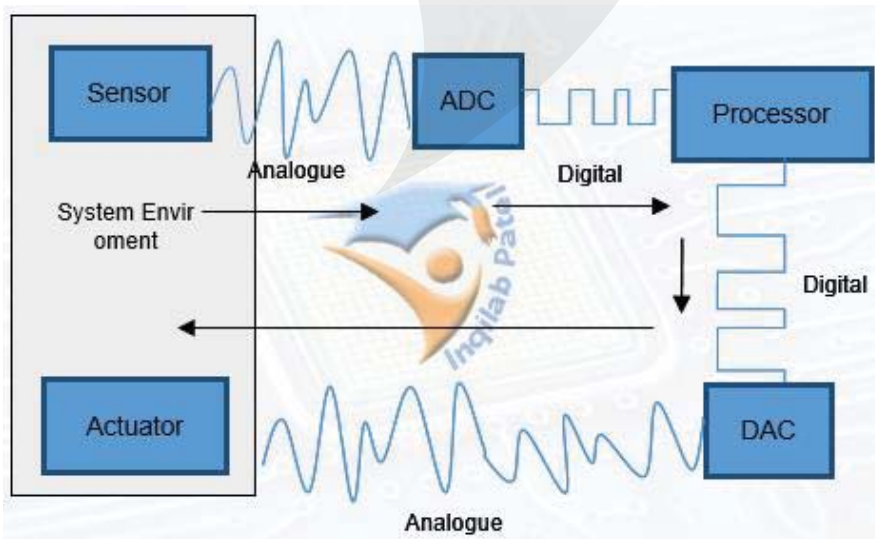

Sensors (general) in control and measuring applications

infra-red/motion	automatic doors, burglar alarm systems
Temperature sensor	Automatic washing machines, automatic cookers, central heating controllers, computer-controlled greenhouses, scientific experiments and environmental monitoring, oven.
Sound/acoustic	Burglar alarm, Leak detection system, Disco lighting
Moisture/humidity	Clothes drier, Environmental control
Pressure sensor	Burglar alarms, automatic washing machines, robotics, production line control, scientific experiments and environmental monitoring
carbon dioxide/ oxygen/gas	pollution monitoring in a river , greenhouse environment (growth control), confined area (e.g. space craft) Fish tank/Aquarium
Light sensor	Computer controlled greenhouses, burglar alarm systems, robotics, production line control, scientific experiments and environmental monitoring
Graphics tablet	Inputting freehand drawings or retouch photographs
Optical Mark Reader	Inputting pencil marks on a form such as a school register, candidate exam answers, any application involving input of a choice of options
Optical Character Reader	Inputting text to a computer ready for processing by another software package such as word processors, spread sheets, databases etc.
Bar code Reader	Inputting code numbers from products at a POS terminal, library books and membership numbers

Monitoring applications

Burglar alarm system

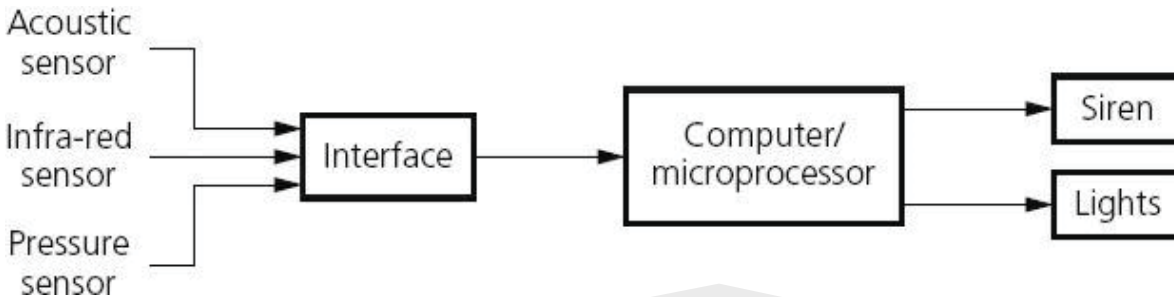

A burglar alarm monitoring system will carry out the following actions:

- The system is activated by keying in a password on a keypad.
- The infra-red sensor picks up the movement of an intruder in the building.
- The acoustic sensor picks up sounds such as footsteps or breaking glass.
- The pressure sensor picks up the weight of an intruder coming through a door or through a window.
- The sensor data is passed through an ADC if it is in an analogue form to produce digital data.
- The computer/microprocessor will sample the digital data coming from these sensors at a given frequency (e.g. every five seconds); the data is compared with the stored values by the computer/microprocessor.
- If any of the incoming data values are outside the acceptable range, then the computer sends a signal to:
 - a siren to sound the alarm, or
 - a light to start flashing.
- A DAC is used if the devices need analogue values to operate them.
- The alarm continues to sound/lights continue to flash until the system is reset with a password.

Monitoring of patients in a hospital

- A number of sensors are attached to the patient; these measure vital signs such as: temperature, heart rate, breathing rate, etc.
- These sensors are all attached to a computer system.
- The sensors constantly send data back to the computer system.
- The computer samples the data at frequent intervals.
- The range of acceptable values for each parameter is keyed in to the computer.
- The computer compares the values from the sensors with those values keyed in.
- If anything is out of the acceptable range, a signal is sent by the computer to sound an alarm.
- If data from the sensors is within range, the values are shown in either graphical form on a screen and/or a digital read out.
- Monitoring continues until the sensors are disconnected from the patient.

Control of street lighting

1. sensor sends signal/data to the microprocessor
2. signal/data converted to digital/using ADC
3. microprocessor compares value to a stored value
4. if input value < stored value ...
 - a. signal sent from microprocessor to actuator
 - b. and light is switched on/off
5. whole process continues in an infinite loop
6. *To Avoid frequent on/off switches:*
7. microprocessor continues to keep light on/off for a pre-determined period
8. after pre-determined period, sensor output is again sampled



Controlling Security Lights

- infrared / motion / pressure (sensor) // sensor detects movement/pressure
- signals/data sent (continuously) to microprocessor
- converted from analogue to digital (using ADC)
- microprocessor compares value with those stored in memory
- if sensor value does not match the stored value(s) ...
 - ... signal sent to switch on the light
 - ... signal sent to keep the light on
 - ... light remains on for a period of time (30 seconds)
- if sensor value matches the stored value(s) ...
 - ... light will remain off
 - ... will turn off after period of time (30 seconds)
- works in a continues loop



The following flowchart shows how a light sensor and microprocessor are used to switch a street lamp on or off. When the sensor reading is ≤ 50 light units, the lamp is turned on automatically. Several of the instructions have been omitted from the flowchart.

Using **item numbers only** from the list below, complete the flowchart:[5]

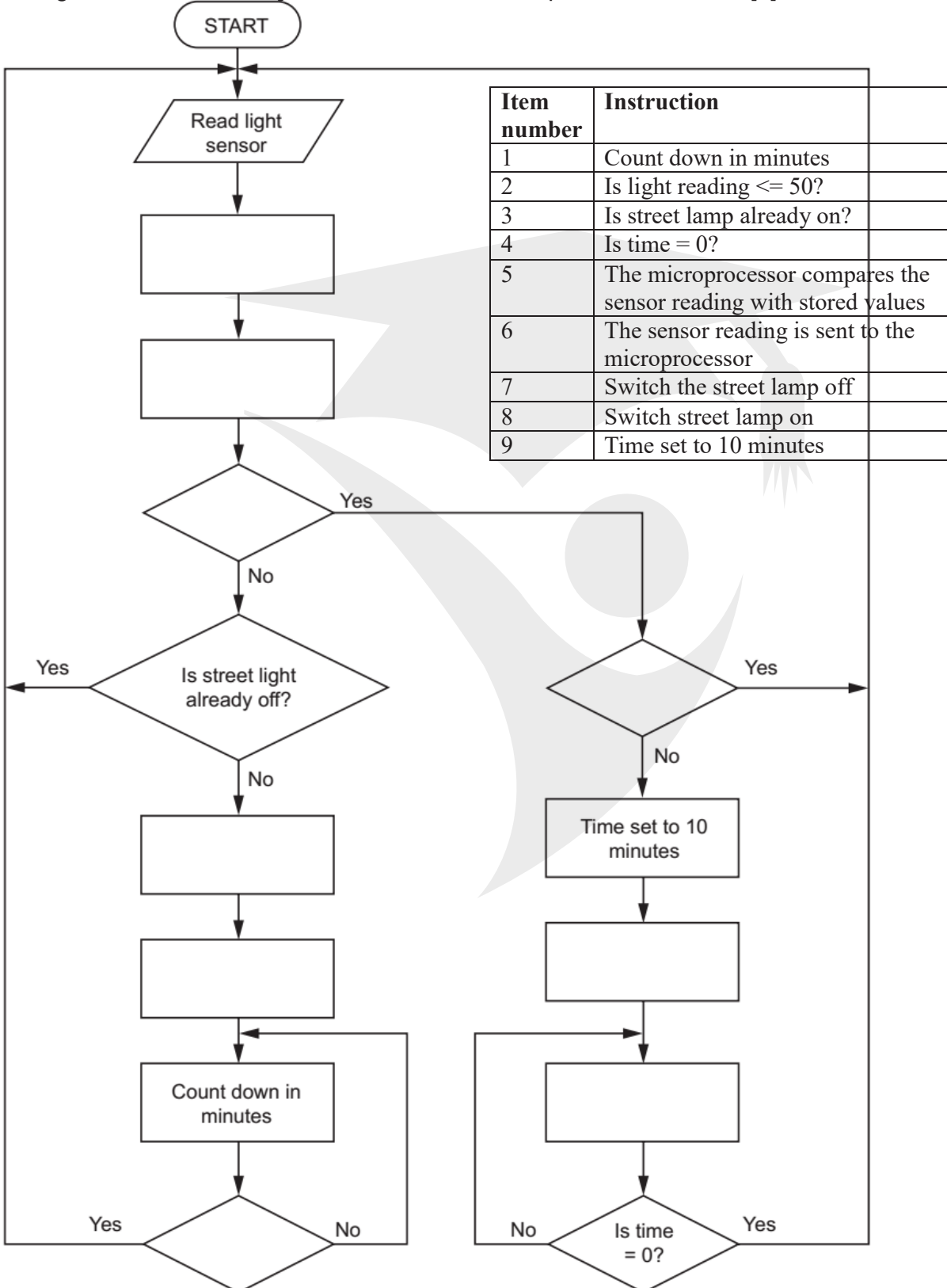

ANTI-LOCK BRAKING SYSTEMS (ABS) on cars use magnetic field sensors to stop the wheels locking up on the car if the brakes have been applied too sharply.

- When one of the car wheels rotates too slowly (i.e. it is locking up), a magnetic field sensor sends data to a microprocessor.
- The microprocessor checks the rotation speed of the other three wheels.
- If they are different (i.e. rotating faster), the microprocessor sends a signal to the braking system:
 - and the braking pressure to the affected wheel is reduced
 - the wheel's rotational speed is then increased to match the other wheels.
- Checking the rotational speed using these magnetic field sensors is done several times a second and the braking pressure to all the wheels can be constantly changing to prevent any of the wheels locking up under heavy braking; this is felt as a 'judder' on the brake pedal as the braking system is constantly switched off and on to equalise the rotational speed of all four wheels.
- If one of the wheels is rotating too quickly, braking pressure is increased to that wheel until it matches the other three.

Question 7a

Example Candidate Response – high	Examiner Comments
<p>7 (a) An office has an automated lighting system. When movement is detected in the office the lights are switched on. If movement is not detected for a period of 2 minutes the lights are switched off. The system uses a sensor and a microprocessor.</p> <p>Describe how the automated lighting system uses a sensor and a microprocessor.</p> <p>An light^{infra-red} sensor 1 can be used..... The data from the light sensor is transmitted..... to a microprocessor. 2 An A.D.C. converts..... analogue data to digital data 3 The..... microprocessor compares the data from..... the sensor with the stored value 4 If..... there or is a movement detected 5 it will send..... a signal to the light to switch on. If no light..... detected for 2 minutes, it will send a signal to..... the light to switch on. This is a continuous..... process 6 and works in an infinite loop..... [6]</p>	<p>1 The first mark is awarded for a correct sensor.</p> <p>2 The second mark is awarded for data transmitted to a microprocessor.</p> <p>3 The third mark is awarded for the conversion of data from analogue to digital.</p> <p>4 The fourth mark is awarded for the comparison of the data to a stored value.</p> <p>5 The reference to movement detected is too vague for the condition tested. The candidate needs to state if the data value to greater than or less than the stored value.</p> <p>6 The fifth mark is awarded for stating the process is continuous.</p> <p>Total mark awarded = 5 out of 6</p>

How the candidate could have improved their answer

The candidate did not give a proper comparison of the data from the sensor and the data stored; they just stated that 'if movement is detected'. If the candidate had indicated that it would mean movement had been detected, for example, the value received was outside the range of the stored values, then another mark could have been awarded.

Example Candidate Response – middle	Examiner Comments
<p>7 (a) An office has an automated lighting system. When movement is detected in the office the lights are switched on. If movement is not detected for a period of 2 minutes the lights are switched off. The system uses a sensor and a microprocessor.</p> <p>Describe how the automated lighting system uses a sensor and a microprocessor.</p> <p>The signals are converted into digital using (ADC) Analogue to digital convert. 1 These signals are then 2 to microprocessor. Then the microprocessor compare the data with the stored value. 3 If both data are equal 4 lights will switch 'ON' and if the received data is not equal 5 to stored value, lights will remain switch 'OFF'. All these signals are sent by sensor to the microprocessor. light sensor 6 is used in this case.</p> <p>[6]</p>	<p>1 The first mark is awarded for converting the analogue data to digital data.</p> <p>2 The candidate is missing saying the signals are sent to the microprocessor.</p> <p>3 A second mark is awarded for the comparison of the data to a stored value.</p> <p>4 A third mark is awarded for the outcome of the comparison.</p> <p>5 The candidate is missing stating the microprocessor sends a signal to switch the lights on.</p> <p>6 This is not a correct sensor for this scenario.</p> <p>Total mark awarded = 3 out of 6</p>

How the candidate could have improved their answer

- The candidate stated that the signals were then to the microprocessor. If they had said they were sent, another mark could have been awarded. The candidate should have checked that they did not miss any vital words from their response.
- When a candidate stated that an action occurred, such as the lights were turned on, they needed to make sure they provided a method for how this had occurred, for example, a signal was sent by the microprocessor to turn the lights on.

Example Candidate Response – low	Examiner Comments
<p>7 (a) An office has an automated lighting system. When movement is detected in the office the lights are switched on. If movement is not detected for a period of 2 minutes the lights are switched off. The system uses a sensor and a microprocessor.</p> <p>Describe how the automated lighting system uses a sensor and a microprocessor.</p> <p>Sensor used: Motion sensor ¹</p> <p>First the sensor detects if there is any movement in the room. Once movement is detected it converts that information ² from analog to digital (through an ADC converter) and the microprocessor compares the recorded value with the set criteria ³. If the criteria is met ⁴ the lights are switched on. If not, it continues to repeat the same process ⁵.</p> <p>[6]</p>	<p>¹ The first mark is given for a correct sensor.</p> <p>² At this stage in the process, the sensor will not send information; it will be just raw data. Therefore, the conversion mark is awarded.</p> <p>³ The candidate is given the benefit of the doubt and is awarded a mark for comparing the value to set criteria, implying that the criteria is a stored value.</p> <p>⁴ This is too vague as it does not say how the criteria is met.</p> <p>⁵ The continuous process mark is not awarded, as the candidate only has this happening if the lights are not switched on.</p> <p>Total mark awarded = 2 out of 6</p>

How the candidate could have improved their answer

- The candidate needed to be aware that data and information were different. If the candidate had stated the data was converted from analogue to digital, a mark could have been awarded for this.
- The candidate needed to make sure they stated that the whole process was continuous and not just part of it.

Common mistakes candidates made in this question

Candidates often made a vague statement, such as 'if motion is detected'. Candidates needed to be more specific and have provided a higher level of response about how the motion was detected, for example, the value received was greater than the value stored.

153 | Page

18a Summer 21 P11

5 Jamelia has a greenhouse that she uses to grow fruit and vegetables. She needs to make sure the temperature in the greenhouse stays between 25°C and 30°C (inclusive).

A system that has a temperature sensor and a microprocessor is used to maintain the temperature in the greenhouse. The system will:

- open a window and turn a heater off if it gets too hot
- close a window and turn a heater on if it gets too cold.

Describe how the system uses the temperature sensor and the microprocessor to maintain the temperature in the greenhouse.

[8]

5	Eight from: <ul style="list-style-type: none">– Sensor send data/readings/signal to microprocessor– Data is converted from analogue to digital (using ADC)– Microprocessor compares/checks data to stored values/range of values...– ... If data is greater than 30 / above the range microprocessor sends signal to open window and to turn heater off– ... If data is below 25 the microprocessor sends signal to turn on heater and to close window– ... If data is between 25 and 30 / within the range no action taken– Actuator is used to operate heater/window– Whole process is continuous	8
---	---	---



18b Summer 21 P12

5 A security light system is used by a factory. The light only comes on when it is dark and when movement is detected. The light will stay on for 1 minute before switching off.

Sensors and a microprocessor are used to control the security light system.

(a) Identify two sensors that would be used in the security light system.

Sensor 1
Sensor 2 [2]

(b) Describe how the sensors and the microprocessor control the security light system.

.....
.....
.....
.....
.....
.....
.....
.....
.....
.....
.....
.....
.....
.....
.....
.....
.....
.....
.....
.....
.....
.....
..... [8]

5(a)	<ul style="list-style-type: none"> - Light sensor - Motion sensor // infra-red sensor 	2
------	---	----------

5(b)	<p>Eight from:</p> <ul style="list-style-type: none"> - Sensors send data to microprocessor - Data is converted to digital (using ADC) - Microprocessor compares data to stored value(s) ... - ... if one value or neither values are within range/out of range/match no action is taken - ... If both values are out of range/in range/match microprocessor sends signal to switch light on ... - ... 1-minute timer is started - Actuator used to switch on/off light - When timer reaches 1 minute, microprocessor sends signal to switch light off - Whole process is continuous 	8
------	--	----------

9(a)	One mark per each correct sensor	3								
	<table border="1"> <thead> <tr> <th>Task</th> <th>Sensor</th> </tr> </thead> <tbody> <tr> <td>Check if a vehicle is too high</td> <td>Infrared/light</td> </tr> <tr> <td>Count the vehicles entering the car park</td> <td>Magnetic field // pressure</td> </tr> <tr> <td>Check if a vehicle is parked in a parking space</td> <td>Pressure // magnetic field // infrared/light</td> </tr> </tbody> </table>		Task	Sensor	Check if a vehicle is too high	Infrared/light	Count the vehicles entering the car park	Magnetic field // pressure	Check if a vehicle is parked in a parking space	Pressure // magnetic field // infrared/light
	Task		Sensor							
	Check if a vehicle is too high		Infrared/light							
Count the vehicles entering the car park	Magnetic field // pressure									
Check if a vehicle is parked in a parking space	Pressure // magnetic field // infrared/light									
9(b)	<p>Six from:</p> <ul style="list-style-type: none"> – Sensor sends data to microprocessor – Data is converted from analogue to digital (using ADC) – Data is compared to stored value ... – ... If data is greater than stored value microprocessor sends signal to turn red light on and the green light off – ... If data is less than stored value microprocessor sends signal to turn green light on the red light off – ... If data still within range, no action taken/existing light remains on – Lights turned on/off using actuator – Process is continuous 	6								

Output Devices

An **output device** is any piece of computer hardware equipment used to communicate the results of data processing carried out by an information processing system (such as a computer) which converts the electronically generated information into human-readable form.

Soft Copy: The output displayed on screen or stored in storage devices is soft copy.

Hard Copy: The output printed on paper is hardcopy output.

Inkjet Printer

How inkjet printers work:

S #	Step
1	Printer driver translates data into a suitable format for the printer
2	Printer receives data from the computer and stores the data in the printer's buffer
3	Paper feed stepper motor activated; sheet of paper fed from paper tray
4	The print head moves across page; ink is sprayed each time the print head pauses for a fraction of a second
5	<p>The ink droplets are produced currently using two different technologies.</p> <ul style="list-style-type: none"> • Thermal bubble: tiny resistors create localised heat which makes the ink vaporise. This causes the ink to form a tiny bubble; as the bubble expands, some of the ink is ejected from the print head onto the paper. When the bubble collapses, a small vacuum is created which allows fresh ink to be drawn into the print head. This continues until the printing cycle is completed. • Piezoelectric: a crystal is located at the back of the ink reservoir for each nozzle. The crystal is given a tiny electric charge which makes it vibrate. This vibration forces ink to be ejected onto the paper; at the same time more ink is drawn in for further printing.
6	Paper feed stepper motor advances paper a fraction of a cm after each complete head pass

Why inkjet printers are helping to reduce the cost of manufacturing OLED screens?

Current OLED manufacturing methods rely on evaporation processes, in which the organic materials are deposited onto a glass sheet through a thin metal stencil. But in this method a significant amount of the material is wasted because it disperses all over the mask.

Inkjet OLED printing has the desirable ability to allow precision deposits without the use of a mask. This could be done, for example, by placing OLED pixels on glass or plastic using a portable platform and nozzles in regular atmospheric conditions. Such methods have the potential to increase yields and lower prices.

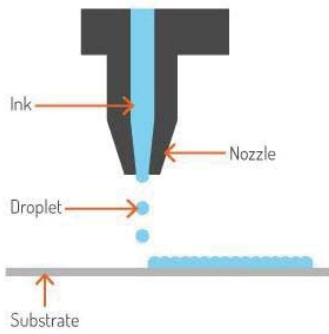

Laser Printer

Laser printers produce very high-quality hard copy output. The print rate per page is very quick if a large number of pages are being printed. They rely on large buffer memories, where the data for the whole document is stored before the pages can be printed out.

How it works

S No	Step
1	The printer driver ensures that the data is in a format that the laser printer can understand
2	Data is then sent to the laser printer and stored temporarily in the printer buffer
3	The printing drum is given a positive charge
4	As the printing drum rotates, a laser scans across it; this removes the positive charge in certain areas
5	Negatively-charged areas are then produced on the printing drum; these match exactly with the text and images to be printed
6	The printing drum is coated in positively-charged toner; this then sticks to the negatively-charged parts of the printing drum
7	A negatively-charged sheet of paper is then rolled over the printing drum
8	The toner on the printing drum is now transferred to the paper to reproduce the required text and images
9	The paper goes through a fuser which melts the toner so it fixes permanently to the paper

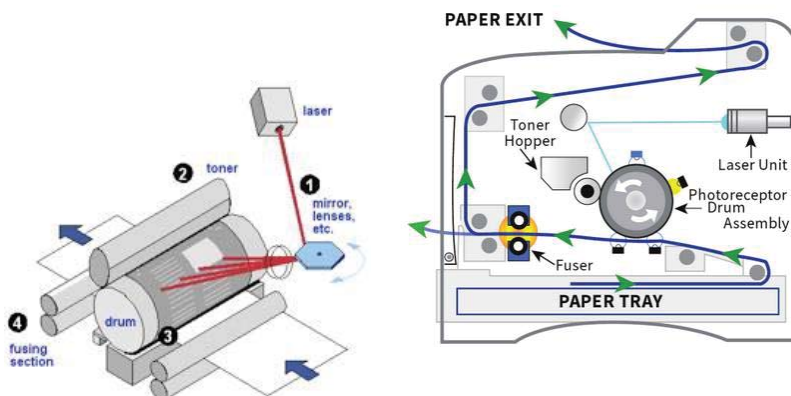

161 | Page

Uses

- Laser printers are used where noise levels need to be kept low (e.g. in an office).
- They are the best option for fast high quality high volume printing.

Advantages

- Printing is fast for high volumes. If only a few pages are to be printed they are little faster than inkjet printers.
- They can handle very large print jobs.
- The quality is consistently high.
- Toner cartridges last for a long time, so laser printers can be a cost effective option, particularly if colour outputs are not required.

Disadvantages

- Laser printers are expensive to buy.
- They are only really fast if several copies are being made.
- Colour laser printers tend to be expensive to run, since four cartridges (three colours plus black) are needed as well as diffuser kits, etc.
- They produce ozone and volatile organic compounds because of their method of printing and type of toner/ink used. These have been linked to health hazards in the office.

Q (a) (i) The following sequence of steps (1 to 7) describe how a single page is printed on a laser printer.

The statements A, B, C and D are used to complete the sequence.

A	The paper passes through a fuser, which heats up the paper. The toner melts and forms a permanent image on the paper.
B	The electrical charge is removed from the drum and the excess toner is collected.
C	The image is converted on the drum into an electrostatic charge.
D	The oppositely-charged paper picks up the toner particles from the drum. After picking up the toner, the paper is discharged to stop it clinging to the drum.

Complete the sequence by writing one of the letters **A**, **B**, **C** or **D** on the appropriate row.

1. A laser beam and a rotating mirror are used to draw an image of the page on the photosensitive drum.
2.
3. Electrostatic charge attracts toner.
4. The charged paper is rolled against the drum.
5.
6.
7. [3]

(ii) A computer user has a laser printer to print letters and documents. The user also prints digital photographs taken using a digital camera.

State the most suitable type of printer for printing the photographs.

.....[1]

163 | Page

Q) The first column of the following table gives features of different types of printer. Put a tick (✓) in the cells to show which features describe a laser and an inkjet printer. [2]

	Type of printer	
	Laser	Inkjet
Impact printer		
Non-impact printer		
Line printer		
Page printer		

3D Printer

3D printing is any of various processes in which material is joined or solidified under computer control to create a three-dimensional object, with material being added together. 3D printing is used in both rapid prototyping and additive manufacturing.

The following describes some of the features of 3D printing:

Various types of 3D printers exist; they range from the size of a microwave oven up to the size of a small car.

3D printers use **ADDITIVE** manufacturing (i.e. the object is built up layer by layer);

Direct 3D printing uses inkjet technology; a print head can move left to right as in a normal printer. However, the print head can also move up and down to build up the layers of an object.

Binder 3D printing is similar to direct 3D printing. However, this method uses

two passes for each of the layers; the first pass sprays dry powder and then on the second pass a binder (a type of glue) is sprayed to form a solid layer.

Newer technologies are using lasers and UV light to harden liquid polymers; this further increases the diversity of products which can be made.

How 3D Printer Works

The steps 1 to 9 describe the basic internal operation of a 3D printer.

The following five statements are used to complete the sequence of steps.

1. The object is designed using Computer Aided Design (CAD) software
2. The software splits the object into slices.
3. The data about the slices is sent to the printer
4. The solid plastic is melted and transferred to the nozzle
5. A stepper motor moves the nozzle into position
6. The nozzle extrudes the molten plastic
7. The steps 5 to 6 are repeated until the layer is complete
8. A fan cools the layer
9. The steps 4 to 8 are repeated for each subsequent layer

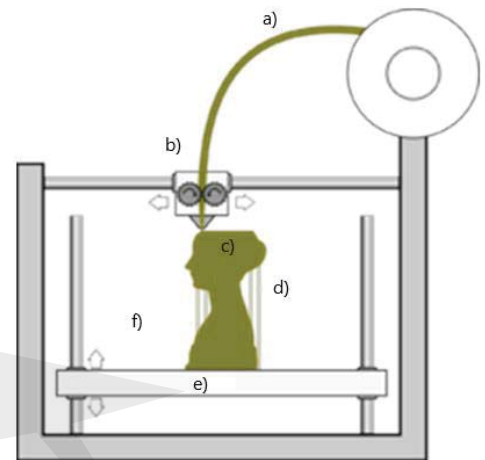

Uses

- 3D printers are used to produce prototypes which actually work from CAD packages, photograph images, stored drawings, etc.
- Scale models are produced in colour before the real thing is manufactured.
- The ultimate objective is to produce organic objects (such as replacement human organs) using this layering technology.

Advantages

- 3D printers save a lot of money, since making prototypes by other methods is very time consuming and expensive.
- Physical scale models are produced with working parts, which gives a better idea of how the end product will look.
- The powders used can often be ground up and re-used.

Disadvantages

- 3D printers are expensive to buy.
- They are slow at producing their output.
- The end product can sometimes be a little rough and often needs further work to be done on it.

165 | Page

2D & 3D Cutter

A 2d and **3d cutter** is a high powered laser that cuts material such as thin metals or woods, used mostly for industrial purposes.

2D cuts a sheet and 3D cutters cuts an object using high power laser beam.

Application:

3D laser cutters can cut the following materials:

- glass
- crystal
- metal
- polymer
- wood.

Benefits:

They make precise and clean cuts, it is also is very fast which makes it efficient.

Drawback:

The main disadvantage of laser cutting is the high power consumption.

Loudspeakers & Headphone

Loudspeakers and headphones are output devices which are used to output sound from computer. Speakers and headphones consist of DAC (Digital to Analogue Converter), Amplifier and diaphragm.

How they work

Microprocessor sends sound signals in digital form, which are converted into analogue using DAC. Then these signals are passed the through an **AMPLIFIER to speaker, whose diaphragm vibrates and produces sound.**

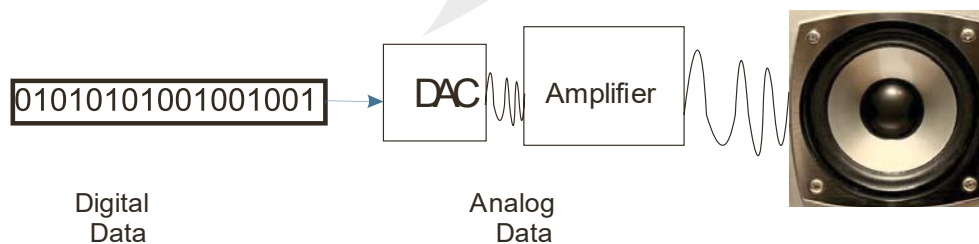

The rate at which the DAC can translate the digital output into analogue voltages is known as the **Application:** Speakers are used to output sound from multimedia presentations.

They are used in home entertainment centres.

They can help blind people (together with speech generation software) through audio output of text on the screen.

They are used to play downloaded sound files.

LCD Monitors

LCD (LIQUID CRYSTAL DISPLAY/DIODE) monitors' front layer is made up liquid crystal diodes; these tiny diodes are grouped together in threes or fours which are known as pixels (picture elements). The three colours which are grouped together use red, green and blue diodes. Those systems that use groups of four include a yellow diode – this is said to make the colours more vivid.

Because LCD doesn't emit any light, some form of back-lit technology needs to be used. They use a cold cathode fluorescent lamp (CCFL) as the back lighting method. Essentially, CCFL uses two fluorescent tubes behind the LCD screen which supplies the light source.

LED Monitors

Modern LCD monitors are back lit using **LIGHT EMITTING DIODE (LED)** technology. This gives the image better contrast and brightness. A matrix of tiny LEDs is used behind the LCD screen.

Advantages of LED over LCD

- LEDs reach their maximum brightness almost immediately (there is no need to 'warm up' before reaching full efficiency)
- LEDs give a whiter light which sharpens the image and make the colours appear more vivid; CCFL had a slightly yellowish tint
- LEDs produce a brighter light which improves the colour definition
- monitors using LED technology are much thinner than monitors using CCFL technology
- LEDs last almost indefinitely; this makes the technology more reliable and means a more consistent product
- LEDs consume very little power which means they produce less heat as well as using less energy.

OLED Monitors

OLED ORGANIC LIGHT EMITTING DIODES use organic materials (made up of carbon compounds) to create semi-conductors which are very flexible. Organic films are sandwiched between two charged electrodes (one is a metallic **CATHODE** and the other a glass **ANODE**). When an electric field is applied to the electrodes they give off light. This means that no form of backlighting is required. This allows for very thin screens.

It also means that there is no longer a need to use LCD technology, since OLED is a self-contained system.

Projectors:

Projectors are output devices used to project computer output onto larger screens or even onto interactive whiteboards.

There are two common types of projectors:

- 1) Digital Light Projector
- 2) LCD Projector

Digital Light Projector (DLP):**How it works:**

1. Millions of micro mirrors are used
2. Micro mirrors tilt towards light source are ON
3. Micro mirrors tilt away from light source are OFF
4. 1024 grey shades are produced for grey scale image
5. To produce a colour image light source is passed through colour filter. (primary colour are RGB)
6. DLP projector can display 16 million colours

LCD Projector: This is an older technology

How it Works

1. A powerful beam of white light is generated from a bulb or LED inside the projector body.
2. This beam of light is then sent to a group of chromatic-coated mirrors; these reflect the light back at different wavelengths.
3. When the white light hits these mirrors, the reflected light has wavelengths corresponding to red, green and blue light components.
4. These three different coloured light components pass through three LCD screens; these screens show the image to be projected as millions of pixels in a grey scale.
5. When the coloured light passes through the LCD screens, a red, green and blue version of the grey image emerges.
6. These images are then combined using a special prism to produce a full colour image – this final image consists of millions of colours (each shade of grey in the original image produces a different shade in each of the colour images).
7. Finally the image passes through the projector lens onto a screen.

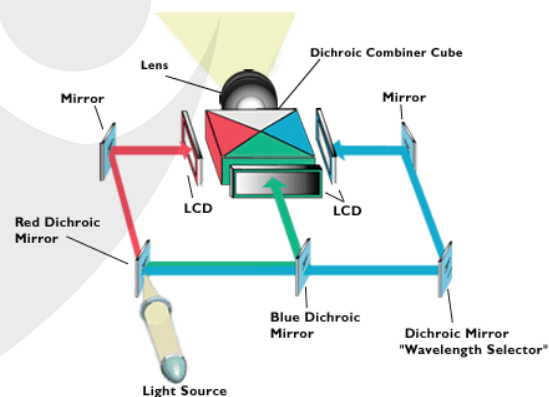

Fill in missing statements

Questions are most commonly set from steps of bar code reading, sensors, operating ATM machine etc.

Steps of bar code reading:

When barcode has been read, then what happens?

- The barcode number is looked up in the stock database (the barcode is known as the **KEY FIELD** in the stock item record); this key field uniquely identifies each stock item.
- When the barcode number is found, the stock item record is looked up.
- The price and other stock item details are sent back to the checkout (or **POINT OF SALE TERMINAL (POS)**).
- The number of stock items in the record is reduced by one each time the barcode is read.
- This new value for number of stock items is written back to the stock item record.
- The number of stock items is compared to the re-order level; if it is less than or equal to this value, more stock items are *automatically* ordered.
- Once an order for more stock items is generated, a flag is added to the record to stop re-ordering every time the stock item barcode is read.
- When new stock items arrive, the stock levels are updated in the database.

Q1: Winter 2006

The following flowchart shows how the bar code written on an item is used to find the price, do stock control and produce an itemised bill. Select statements from the list below to complete the flowchart.

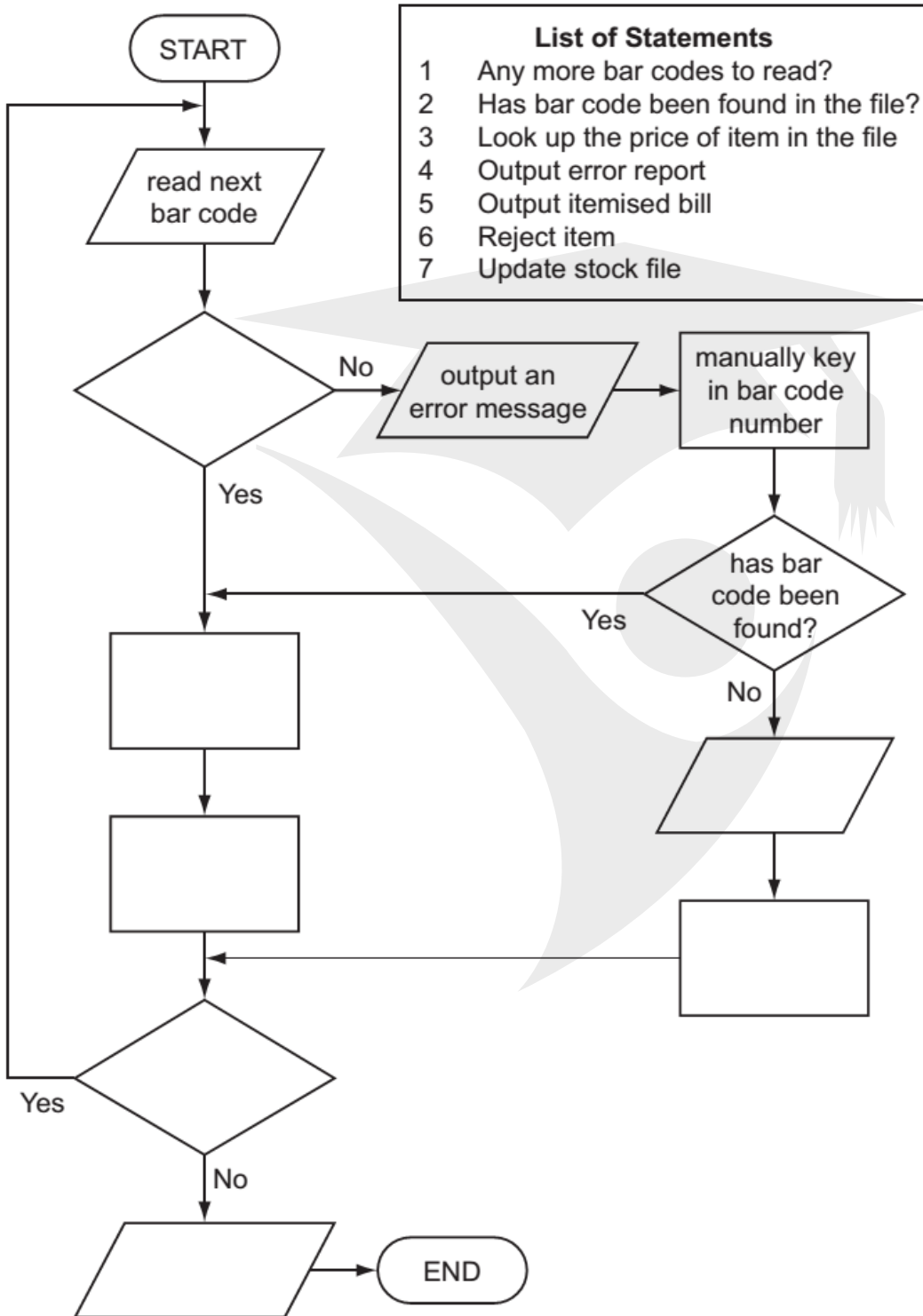

Q3: Winter 2008

The following flowchart shows how sensors (which can be analogue or digital) and a computer are used to control the temperature of a greenhouse for plants. Complete the flowchart using the items from the list below.

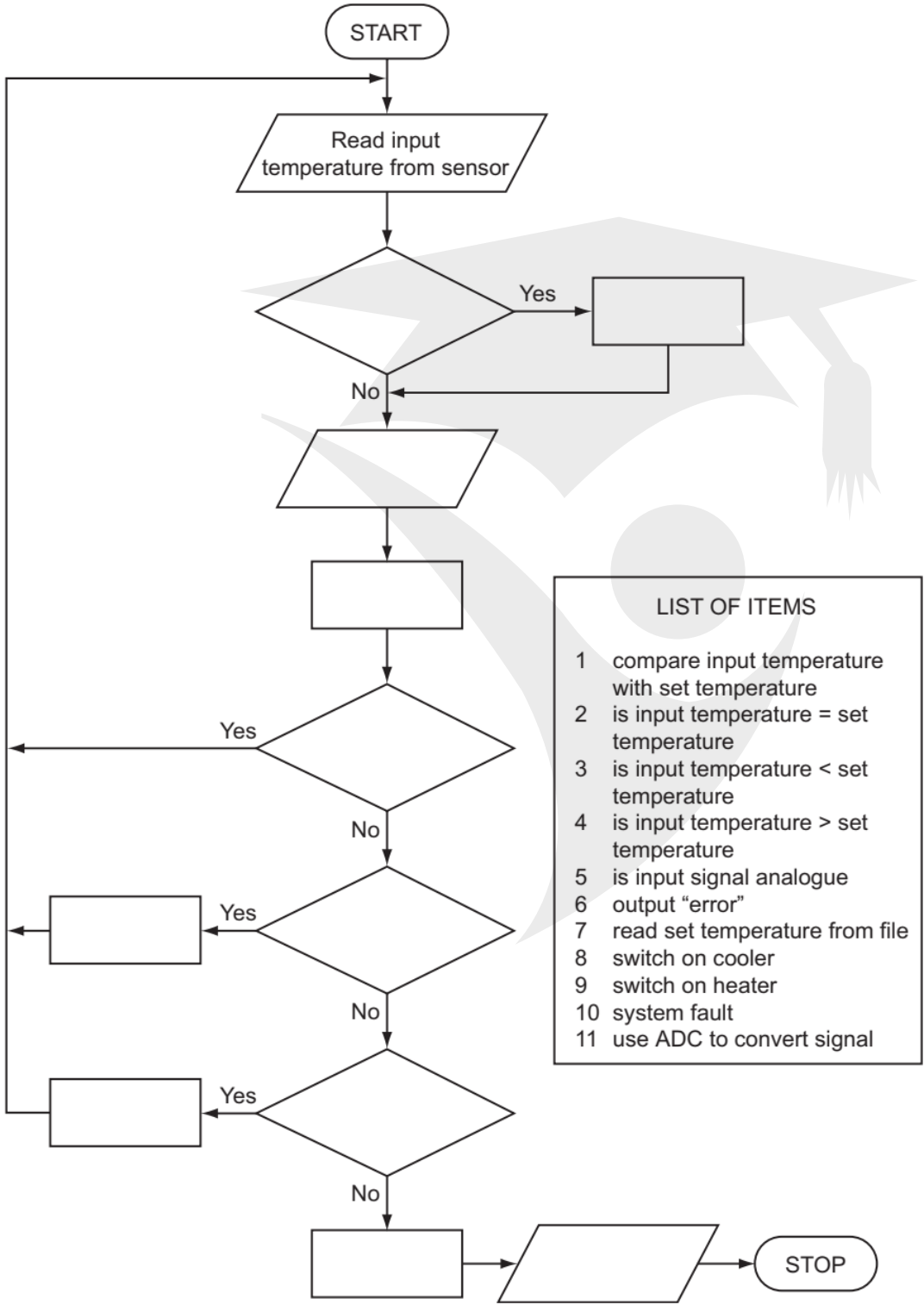

Q10: Winter 2013. P13

A microprocessor controls the opening and closing of automatic doors to a supermarket. Customers are detected using pressure sensors.

The flowchart on the next page shows how the sensors and microprocessor interact to control the opening and closing of the doors. However, several of the stages in the process have been missed out.

Using item number only, complete the flowchart using items from the following list:

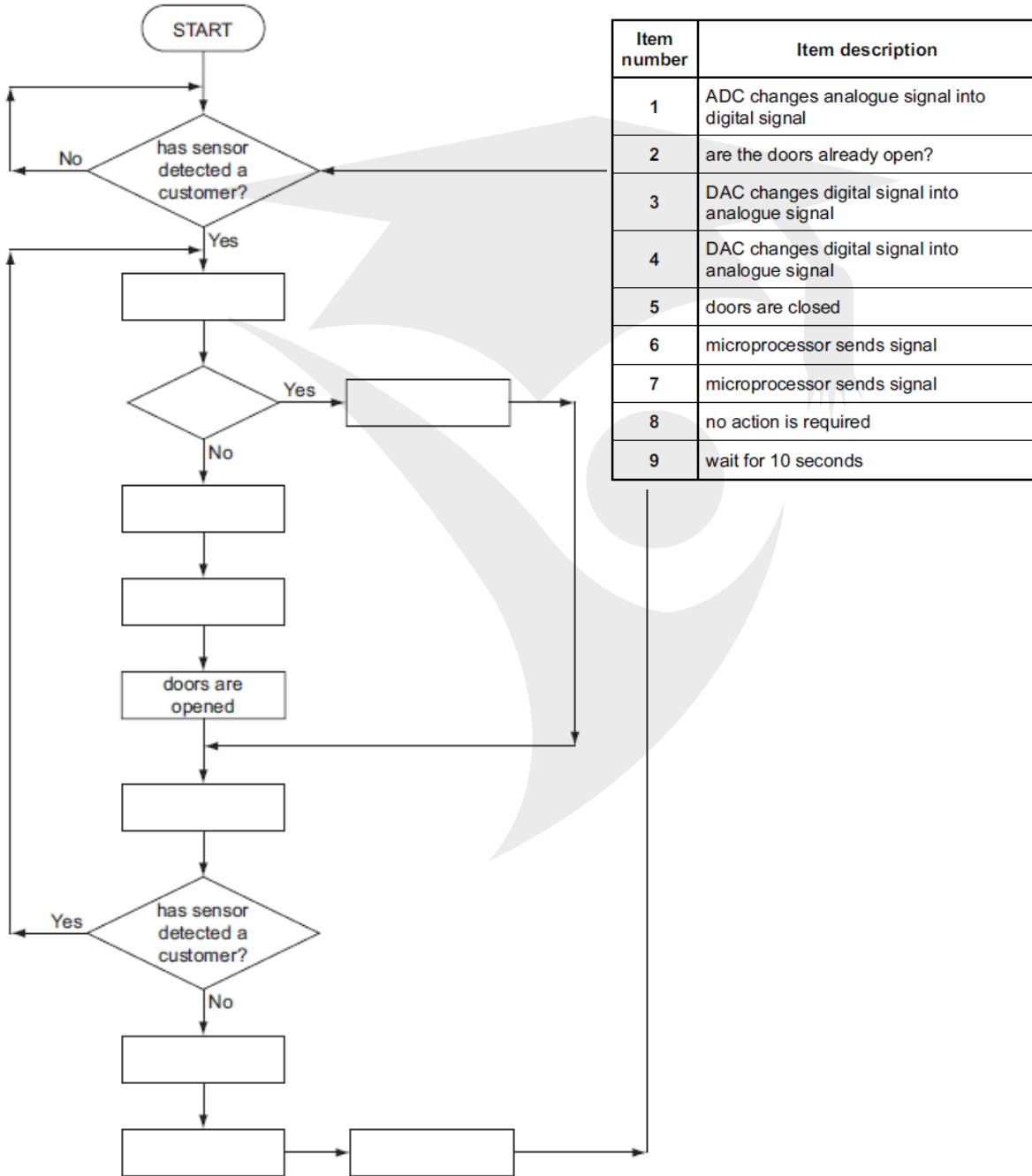

[5]

Topical Past Papers

18c Summer 21 P13

3 An optical mouse is a type of input device that can be used to input data into a computer system.

(a) Complete the paragraph about the operation of an optical mouse, using the most appropriate terms from the given list. Not all terms need to be used.

- Ball • Battery • LCD • LED • Lens • Magnifies
- Matrix • Microswitch • Photoelectric • Photographic • Reduces • USB

An optical mouse shines an from the bottom of the mouse onto a surface. Light bounces straight back from the surface into a cell. This has a that the reflected light to allow detection of smaller movements. When a button on the mouse is clicked, a is pressed. A connection is used to carry the data to the computer. [6]

(b) Identify two other input devices that can be used to enter data into a computer.

1

2 [2]

3(a)	<p>One mark per each correct term, in the correct place.</p> <ul style="list-style-type: none"> - LED - Photoelectric - Lens - Magnifies - Microswitch - USB 	6
3(b)	<p>Any two from:</p> <ul style="list-style-type: none"> - Keyboard - Microphone - 2D/3D Scanner - Sensor - Touchscreen - Keypad - Webcam - Joystick 	2

Q 1) Summer 2015 P11

8 (d) The LCD (liquid crystal display) on the clock face is back-lit using blue LEDs (light emitting diodes). The brightness of the clock face is determined by the level of light in the room. The amount of light given out by the LEDs is controlled by a control circuit.

Describe how the sensor, microprocessor and LEDs are used to maintain the correct brightness of the clock face.

.....
.....
.....
.....
.....
.....
.....
.....
.....
.....
.....[3]

(e) Modern LCD monitors and televisions use LED back-lit technology.

Give two advantages of using this new technology compared to the older cold cathode fluorescent lamp (CCFL) method.

1
.....
.....
.....
2
.....
.....[2]

Q 2) Summer 2015 P12

2 The majority of mobile phones use touch screens. Three common technologies are used by different mobile phone manufacturers. Choose one of the following mobile phone technologies:

- resistive • capacitive • infrared

Chosen technology

(i) Describe how your chosen technology works to allow a user to make selections by touching the screen.

.....
.....
.....
.....
.....[2]

(ii) Give **one** benefit and **one** drawback of your chosen technology when used on mobile phone touch screens.

Benefit

.....

Drawback

..... [2]

3 Four input devices, four descriptions and four applications are shown below. Draw a line to connect each input device to its correct description. Then connect each description to its correct application. [6]

Input device	Description	Application
barcode reader	copies paper documents and converts the text and pictures into a computer-readable form	voice recognition
microphone	reads labels containing parallel dark and light lines using laser light or LEDs; the width of each line represents a binary code	reading passports
pH sensor	detects changes in acidity levels; data is often in analogue form	automatic stock control
scanner	device that allows audio signals to be converted into electric signals; these can be interpreted by a computer after being converted into digital form	monitor soil in a greenhouse

Examiner's comments on Question 3

Many candidates displayed an excellent level of knowledge input devices and their uses, gaining five or six marks for the answer. The most common error was candidates confusing stock control and reading passports.

Q 3) Winter 2015 P12

3 The flowchart on the opposite page shows what happens when the barcode on a product is scanned at the checkout in a supermarket. The barcodes are used in an automatic stock control system.

Several of the statements in the flowchart are missing.

Using **item number only** from the list below, complete the flowchart. [4]

Item number	Statement
1	Add flag to product record to indicate re-order made
2	Any more barcodes to scan?
3	Has the scanned barcode been found in the file?
4	Has the re-order flag already been added to the product record?
5	Is number of product in stock \leq re-order level?
6	Number of product in stock is reduced by 1
7	Output an error message
8	Automatically send out order for new product

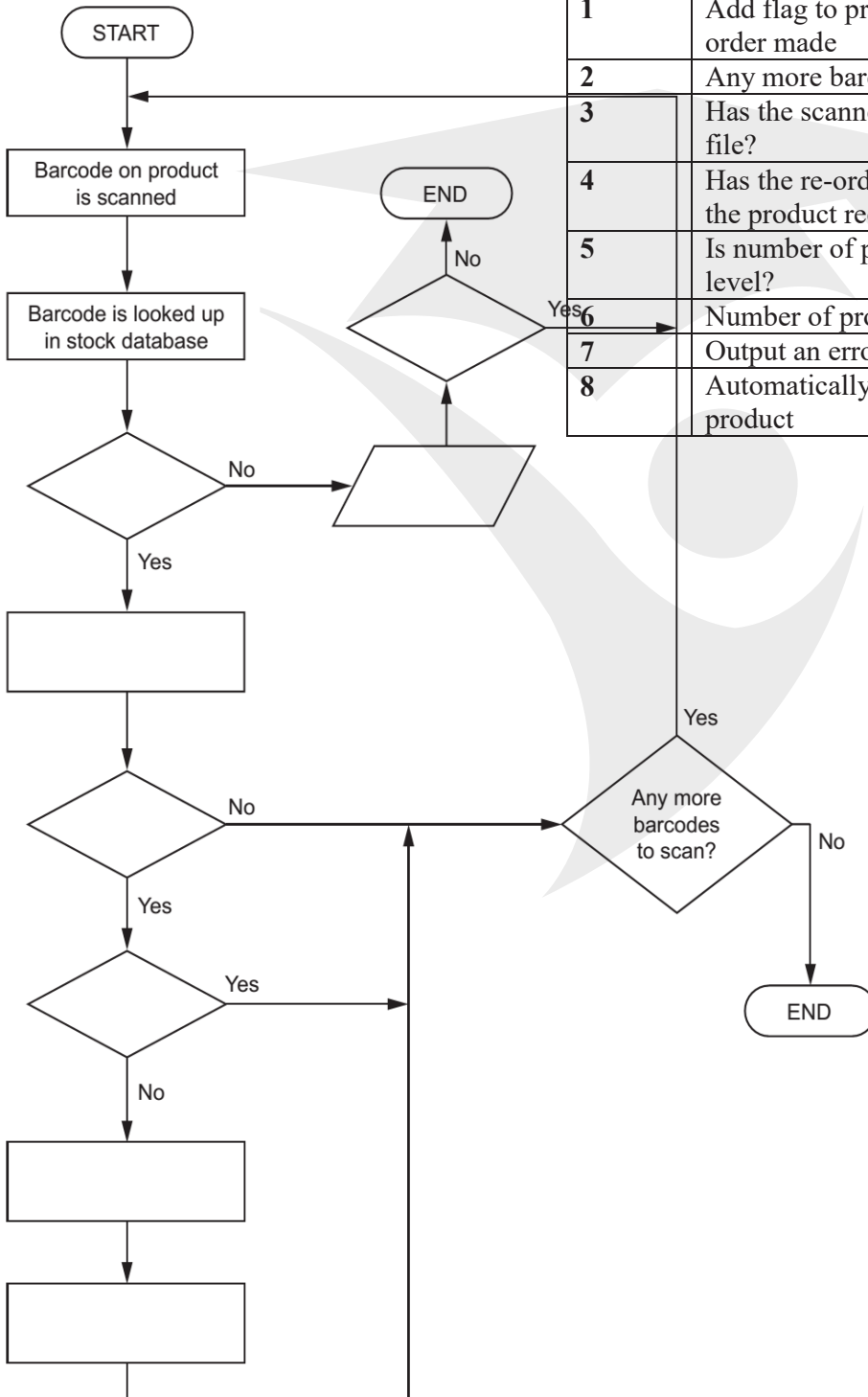

179 | Page

8 The steps to print a document using a laser printer are shown in the table below.

Put each step in the correct order. The first step has been done for you. [8]

Step	Order
As the printing drum rotates, a laser scans across it; this removes the positive charge in certain areas	
The printing drum is coated in positively-charged toner; this then sticks to the negatively-charged parts of the printing drum	
The paper goes through a fuser which melts the toner so it fixes permanently to the paper	
The printer driver ensures that the data is in a format that the laser printer can understand	1
A negatively-charged sheet of paper is then rolled over the printing drum	
Data is then sent to the laser printer and stored temporarily in the printer buffer	
The toner on the printing drum is now transferred to the paper to reproduce the required text and images	
The printing drum is given a positive charge	
Negatively-charged areas are then produced on the printing drum; these match exactly with the text and images to be printed	

Q 4) Winter 2015 P13

1 (a) Name an application which makes use of the following sensors. A different application should be used in each case.

Temperature

Magnetic field

Motion

..... [3]

(b) The flowchart on the opposite page shows how a light sensor and microprocessor are used to switch a street lamp on or off. When the sensor reading is ≤ 50 light units, the lamp is turned on automatically.

Several of the instructions have been omitted from the flowchart.

Using **item numbers only** from the list below, complete the flowchart:[5]

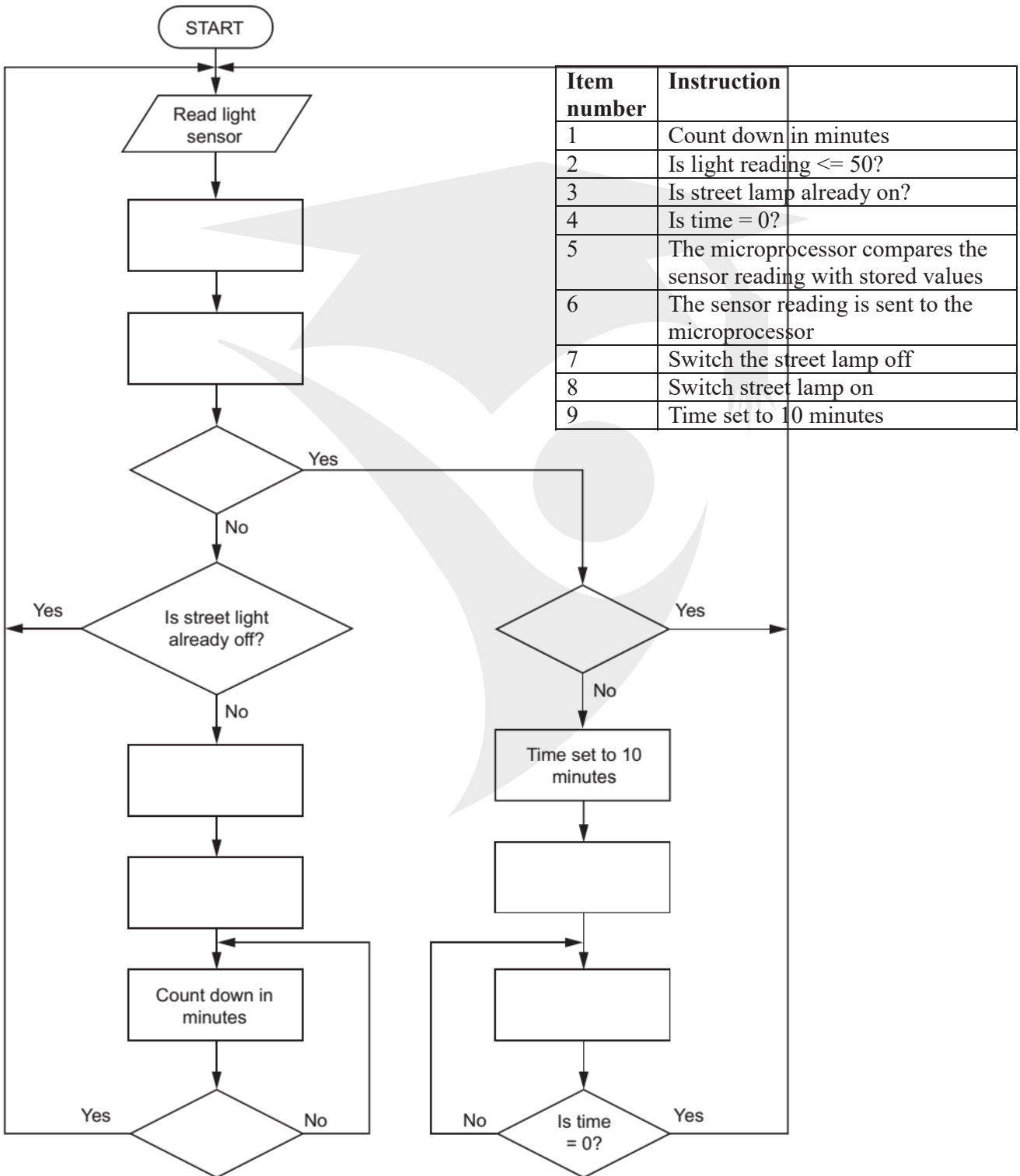

181 | Page

7 Name a suitable output device for each of the following applications. A different device should be used for each application.

Application	Suitable output device
Production of one-off photographs of very good quality	
High volume colour printing of advertising flyers	
Production of an object, which is built up layer by layer; used in CAD applications	
Converting electrical signals into sound	
Showing enlarged computer output on a wall or large screen	

8 Four input devices are shown in the table below.

Give an application which makes use of each device and state a reason why the device is appropriate for that application. Your application must be different in each case.

Input device	Application and reason
Light sensor	Application Reason
Keyboard	Application Reason
Barcode reader	Application Reason
Touch screen	Application Reason

Q 5) Winter 2015 P11

5 (a) Inkjet printers and laser printers are two common types of printer.

Describe the features and principles of operation of each type of printer.

(i) Inkjet printer
.....
.....
.....
..... [4]

(ii) Laser printer:

.....

.....

.....

..... [4]

(b) Another type of printer is the 3D printer.
Describe 3D printing.

.....

.....

..... [3]

1 (a) Four hardware items are shown in the table below.

For each hardware item:

- name a suitable application
- state how it is used in the application

Give a different application in each case.

[8]

Hardware item	Application	How the hardware item is used
Microphone
Barcode reader
Touch screen
Infrared sensor

183 | Page

11 A passenger logs onto an airline website and types in the reference number for their flight. Once the passenger accesses their account they can choose their seat and also print out a boarding pass which contains a unique barcode. This barcode is scanned at the airport check-in desk.

Name **one** input and **one** output device found at the check-in desk and give a reason for your choice.

Input device:

Reason:

Output device:

Reason:

.....[4]

Q 6) Summer 2016 P11 & P13

3 (a) Five sensors and five applications are shown below.

Draw a line to link each sensor to its most appropriate application. [4]

(a) Nikita wishes to print out some documents and connects her printer to the computer using one of the USB ports.

Sensor	Application
Light sensor	Monitor the pollution levels in a river
Moisture sensor	Control the switching off and on of street lights
Gas sensor	Detect intruders breaking into a building
pH sensor	Monitor the amount of water left in clothes in a dryer
Pressure	Monitor acidity levels in the soil in a green house

184 | Page

4 a(iii) The printer runs out of paper while it is printing the documents. A signal is sent to the processor to request that the problem is dealt with.

Name this type of signal.:[1]

(b) State one suitable application for each printer below. A different application must be given for each printer.

Inkjet printer

.....

3D printer

..... [2]

(c) Name another type of printer and describe one way in which it is different from the printers named in part (b).

Give an application for this printer.

Type of printer

Description

.....

.....

Application

..... [3]

12 (a) Name the following type of barcode:



.....[1]

(c) An airport uses the type of barcode shown in part (a) to advertise local places of interest. Describe how a visitor landing at the airport could use these barcodes to help plan their visit.

.....

.....

.....

.....

.....

.....

.....[3]

Q 11) Summer 2017 P11

9 A supermarket has a system that allows customers to check out their own shopping. Identify and describe the purpose of **two** input devices and **one** output device used in this system.

Input device 1
Purpose

Input device 2
Purpose

Output device 1
Purpose [6]

Q 9) Winter 2016 P11& 13

4 The Henslows Diner is a local restaurant.

(a) Staff currently use a keyboard to input a customer food order into a computer. The food order is then sent to the kitchen.

State **two** disadvantages of using a keyboard to input a customer food order.

1
2 [2]

b) A concept keyboard has a flat surface that is overlaid with images of food items available from the restaurant menu. Staff can click on an image to add the food item to a customer food order.

The Henslows Diner wants to change to a concept keyboard to input customer food orders.

Explain **two** benefits of making this change.

1
.....
.....

186 | Page

.....

2

.....

.....

[4]

7 Modern Liquid Crystal Display (LCD) monitors use Light-Emitting Diode (LED) backlit technology. Give **four** benefits of using LED technology.

1

.....

.....

2

.....

.....

3

.....

.....

4

.....

[4]

10 Describe the differences between a barcode and a Quick Response (QR) code.

.....

.....

.....

.....

.....

.....

.....

.....

[3]

Q 12) Summer 2017 P12

3 The diagram shows **five** output devices and **five** descriptions.
Draw a line between each output device and its description. [4]

Output Device	Description
Inkjet printer	Flat panel display that uses the light modulating properties of liquid crystals.
LCD screen	Flat panel display that uses an array of light-emitting diodes as pixels.
2D cutter	Droplets of ink are propelled onto paper.
LED screen	Electrically charged powdered ink is transferred onto paper.
Laser printer	High powered laser that uses the x-y plane.

Examiner Comment on Q 3

Most candidates correctly match the five terms to the correct descriptions.

6 Airline boarding passes can be read from a smart phone instead of a printout.

Identify what type of barcode **A** is an example of. Explain how the data stored in this type of barcode is read.

.....

.....

.....

.....

.....

.....

.....

.....

.....

..... [4]

Q 15) March 2018 P12 (India)

12 A hospital stores the results of medical tests on a computer system. Each patient is given a wristband containing a unique barcode. The barcode is used every time the patient has a medical test.

(a) Explain two benefits of using barcodes in this situation.

Benefit 1
.....

Benefit 2
.....
.....[4]

(b) Describe how the barcode is read.

.....
.....
.....
.....
.....
.....
.....
.....
.....
.....
.....[4]

Q 16) Summer 2018 P11

1 Jane answers an examination question about computers and data correctly.

Six different words or numbers have been removed from her answer.

Complete the sentences in Jane's answer, using the list given. Not all items in the list need to be used.

- 2 • 10 • 16 • analogue
- binary • denary • digital • hexadecimal

As humans, we process data, but a computer cannot process this type of data. For a computer to be able to process data it needs to be converted to data.

As humans, we mostly use a number system; this is a base number system.

Computers use a number system; this is a base number system. [6]

8 A supermarket uses a barcode scanner to read the barcodes on its products.

(a) Describe how the barcode scanner reads the barcode.

.....
.....
.....
.....
.....
..... [4]

(b) Explain how the barcode system could help the supermarket manage its stock.

.....
.....
.....
.....
..... [3]

(c) An infrared touch screen is used to view and navigate the supermarket stock system.

Explain how the infrared touch screen detects a user's touch.

.....
.....
.....
.....
..... [4]

Q 17) Summer 2018 P12

2 (a) Nancy has captured images of her holiday with her camera. The captured images are stored as digital photo files on her camera.

Explain how the captured images are converted to digital photo files.

.....
.....
.....
..... [4]

9 An advertisement in a magazine displays this barcode:

(a) Identify this type of barcode.

..... [1]

(b) Explain how the data stored in this barcode is read.

.....
.....
.....
.....
.....
.....
.....
.....
.....
.....
..... [4]

10 Alexandra has a new mobile device.
It has a touch screen that uses capacitive technology.

(a) Describe how a capacitive touch screen registers Alexandra's touch.

.....
.....
.....
.....
.....
.....
.....
.....
.....
.....
..... [4]

(b) Alexandra is wearing gloves because it is cold.
She presses an icon on her touch screen but her action is not registered.

(i) Explain why the touch screen will not register her touch.

.....
.....
.....
..... [2]

(ii) Alexandra does not want to remove her gloves.
Explain how Alexandra could use her mobile device whilst still wearing gloves.

.....

.....
.....
..... [2]

Q 18) Winter 2018 P12

5 (a) Karina is taking her Computer Science examination. She has three questions to answer about output devices.

(i) For the first question she writes the answer:

“It is a high powered laser that cuts materials such as thin metals or wood.”

Identify the output device that Karina is describing.

.....[1]

(ii) For the second question she writes the answer:

“The screen is made up of blocks of red, green and blue pixels. The screen uses layers of different types of liquid.” Identify the output device that Karina is describing.

.....[1]

(iii) For the third question she writes the answer:

“It is responsible for powering and moving a motor in machinery, such as a robot arm in a factory.”

Identify the output device that Karina is describing.

.....[1]

(b) Karina correctly answers another examination question about some more output devices.

Five different terms have been removed from her answer.

Complete the sentences in Karina’s answer, using the list given. Not all terms in the list need to be used.

- 3D • digital light projector • inkjet • interactive whiteboard • laser
- rotating • thermal bubble • scanning • sliding • speaker

An allows a user to write on a surface using a pen, the text and drawings can then be captured and stored for later use.

An printer produces a hard copy of a document using and piezoelectric technology. A printer uses

a drum, and positive and negative charges, to produce a hard copy of a document. [5]

Q 19) Winter 2018 P13

1 There are six output devices and six descriptions shown. Draw a line to connect each output device to the most appropriate description. [5]

Description	Device
Laser Printer	Uses a high-intensity beam of light shone through three layers of changing pixels
LCD Projector	Uses millions of micro mirrors to reflect light through a lens
Digital Light Projector (DLP)	Uses plastic, resin or powdered metal to generate a physical output
Inkjet Printer	Uses a static electric charge on a rotating drum to generate a physical output
3D Printer	Uses liquid ink to generate a physical output
2D Cutter	Uses a high-power laser to generate a physical output

Q 20) March 2019 P12

2 Many computer systems have an input device and an output device.

(a) (i) State what is meant by an input device.

..... [1]

(ii) Give an example of an input device.

..... [1]

(b) (i) State what is meant by an output device.

..... [1]

(ii) Give an example of an output device.

..... [1]

194 | Page

Q 21) Summer 2019 P11

3 **Five** descriptions of different input or output devices are given in the table.

Complete the table by stating the **name** of each input or output device. [5]

Description	Name of device
This is an input device that works by shining a light onto the surface of a document. The light source is automatically moved across the document and the reflected light is captured by mirrors and lenses.
This is an input device where a laser or a light source is moved across an object. The width, height and depth of the object are measured to allow a model to be created.
This is a large input device that is usually fixed to a wall. A user can calibrate the device to make sure the sensors align with a projected image. The user can use either their finger or a special pen to make selections.
This is an output device that uses many small mirrors to reflect light towards a lens. This will display an image.
This is an output device that creates an object by building layer upon layer of material.

Q 22) Summer 2019 P12

1 Input and output devices are often connected to a personal computer.

(a) Identify **three** input devices that can be connected to a personal computer.

- 1
- 2
- 3 [3]

(b) Identify **three** output devices that can be connected to a personal computer.

- 1
- 2
- 3 [3]

4 (ii) Marley prints the images for his project using an inkjet printer.

Describe how the inkjet printer prints an image.

.....

 [4]

Q 24) Winter 2019 P12

6 Touch screen technologies can be described as resistive or capacitive.

Six statements are given about resistive and capacitive technology.

Tick (✓) to show if the statement applies to **Resistive** or **Capacitive** technology. [6]

Statement	Resistive (✓)	Capacitive (✓)
This touch screen has multi-touch capabilities		
This touch screen cannot be used whilst wearing gloves		
This touch screen is made up of two layers with a small space in between		
This touch screen uses the electrical properties of the human body		
This touch screen is normally cheaper to manufacture		
This touch screen has a quicker response time		

Q 26) Summer 20 P12

6 Six statements are given about touch screen technology.

Tick (✓) to show if the statement applies to **Capacitive** or **Resistive** touch screen technology. [6]

Statement	Capacitive (✓)	Resistive (✓)
Needs pressure to be applied to create a circuit		
May not register a touch if the user is wearing gloves		
More commonly used in smartphones		
More responsive to a touch		
Needs an electrical field to be changed to register a touch		
Cheaper to manufacture		

8 Leonard has a new laser printer to print letters for his business.

Leonard connects his printer to his computer using the USB port.

(a) Give **three** benefits of using the USB port to connect the printer to the computer.

Benefit 1

.....

Benefit 2

.....

199 | Page

Benefit 3 [3]

(b) State **two** benefits and **one** drawback of Leonard using a laser printer, instead of an inkjet printer, to print the letters.

Benefit 1

Benefit 2

Benefit 3

Drawback

.....[3]

(c) An interrupt signal is sent from the printer to the computer.

(i) Give **two** examples of when a printer would generate an interrupt signal.

Example 1

Example 2

[2]

(ii) Many devices send interrupt signals.

Identify the software in the computer that will receive and manage all interrupt signals.

.....

[1]

Q 27) 15a Summer 20 P11

1 An image of a smartphone is shown.

(a) Identify **one** input device that is part of the smartphone.

.....

[1]

(b) Identify **two** output devices that are part of the smartphone.

1

2

[2]

6 **Four** scenarios are given.

Identify the most suitable sensor for each scenario.

A **different** sensor must be used for each scenario.

[4]

Sensor	Scenario
	Detecting when a person is approaching an automatic door system
	Monitoring the pollution level in a river

	Checking if a tropical aquarium is 25 degrees Celsius
	Counting the number of cars that cross a bridge

8 Benny is a photographer and prints his photos using an inkjet printer.

(a) Benny is printing some photos and the paper gets jammed in the printer.

A signal is sent to alert the computer about the paper jam.

State the name of this type of signal.

..... [1]

(b) Identify **one** benefit and **two** drawbacks of Benny using an inkjet printer, instead of a laser printer, to print his photos.

Benefit

.....

Drawback 1

.....

Drawback 2

..... [3]

(c) **Four** statements are given about printers.

Tick (✓) to show whether the statement applies to an **Inkjet** printer or a **Laser** printer. [4]

Statement	Inkjet (✓)	Laser (✓)
Uses a rotating drum to transfer the image to the paper		
Uses powdered toner		
Uses nozzles to spray droplets on to the paper		
Uses a print head mechanism that moves side to side		

Q 28) Winter 20 P12

1 (c) Tina uses a microphone to record a welcome message for her website.

(i) State whether the microphone is an **input** or **output** device.

..... [1]

5 Tammy is buying a new computer that has an LED display.

202 | Page

(a) Five statements about LED displays are given.

Tick (✓) to show if each statement is **True** or **False**. [5]

Statement	True (✓)	False (✓)
It is a flat panel display		
It creates images using red, green and blue diodes		
It is not very energy efficient and gives off heat		
It can be used in mobile devices such as smartphones and tablets		
It is a front-lit display		

Q 29) Winter 20 P13

1 Five hardware devices are given.

Tick (✓) to show if each device is an **Input**, **Output** or **Storage** device. [5]

Device	Input (✓)	Output (✓)	Storage (✓)
Solid state drive (SSD)			
Headphones			
2D cutter			
LCD projector			
Microphone			

8 Edith is buying a new computer monitor that displays images using LCD technology.

(a) Explain what is meant by LCD technology.

.....

.....

.....

.....

.....

[3]

(b) State **three** benefits of LCD technology.

Benefit 1

.....

Benefit 2

.....

Benefit 3
 [3]

Q 30) March 21 P12

3 The given table shows the name or description of four devices. The table is incomplete. Complete the missing device names and descriptions. [4]

Device name	Description
.....	Uses either thermal bubble or piezoelectric technology
Actuator
.....	Uses thousands of tiny mirrors that can move very quickly to create an image
Mouse

Q 2) Summer 2015 P12

Page 3	Mark Scheme	Syllabus	Paper
	Cambridge O Level – May/June 2015	2210	12

- 2 (i) Either of the three options, **resistive**, **capacitive** or **infra-red** must be chosen maximum of **two** marks from chosen technology:

resistive

- uses multiple layers of material ...
- ... that transmit electric currents
- when the top layer/screen is pushed/touched into the lower/bottom layer ...
- ... the electric current changes and location of "touch" is found

capacitive

- current sent/flows out from all 4 corners of the screen
- when finger/stylus touches screen, the current changes
- the location of "touch" is calculated

infra-red

- an "invisible" grid on the screen (pattern of infra-red LED beams)
- sensors detect where the screen has been touched through a break in an infrared beam(s)
- the position where the screen touched is calculated

[2]

- (ii) 1 mark for **benefit**, 1 mark for **drawback**

Resistive**benefits:**

- inexpensive/cheap to manufacture
- can use stylus/finger/gloved finger/pen

drawbacks:

- poor visibility in sunlight
- vulnerable to scratching
- wears through time
- does not allow multi-touch facility

capacitive**benefits:**

- good visibility in sunlight
- (very) durable surface
- allows multi-touch facility

drawbacks:

- screen (glass) will shatter/break/crack (on impact)
- cannot use when wearing (standard) gloves

infra-red**benefits:**

- good durability
- allows multi-touch facility
- can use stylus/finger/gloved finger/pen

drawbacks:

- expensive to manufacture
- screen (glass) will shatter/break/crack (on impact)
- sensitive to dust/dirt

[2]

Page 4	Mark Scheme	Syllabus	Paper
	Cambridge O Level – May/June 2015	2210	12

3

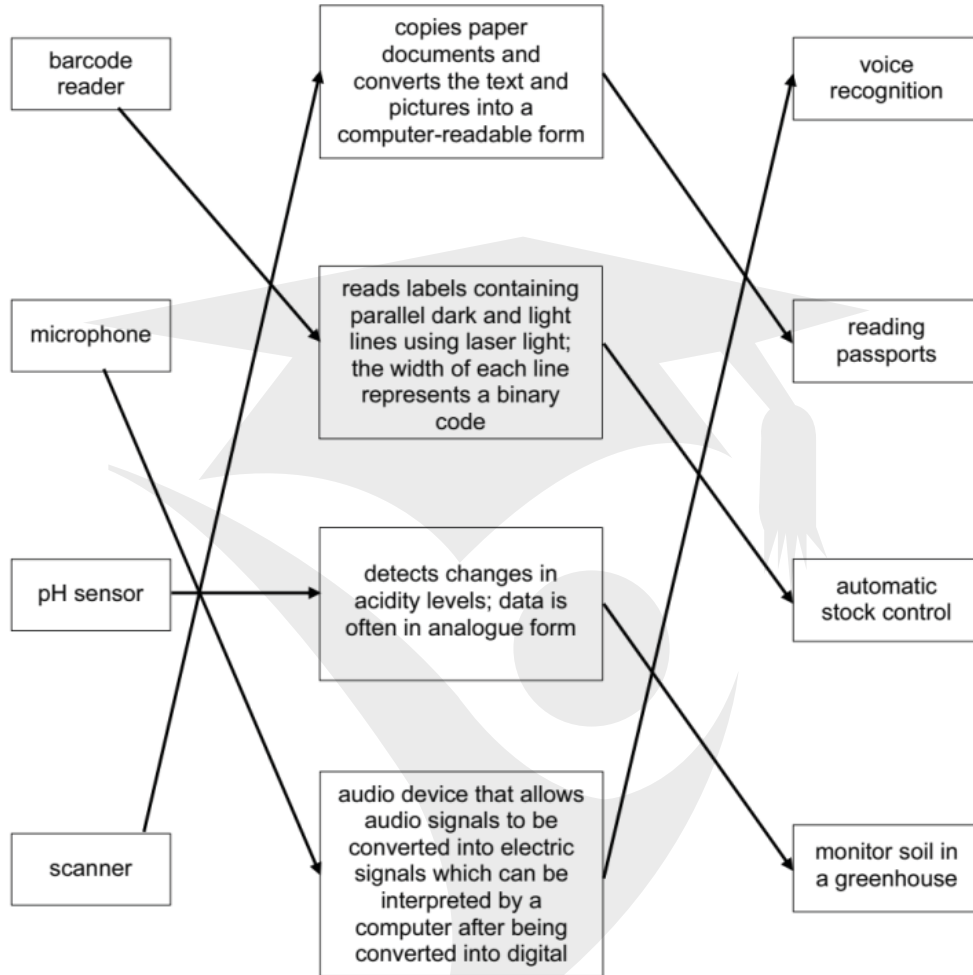

Q 3) Winter 2015 P12

3

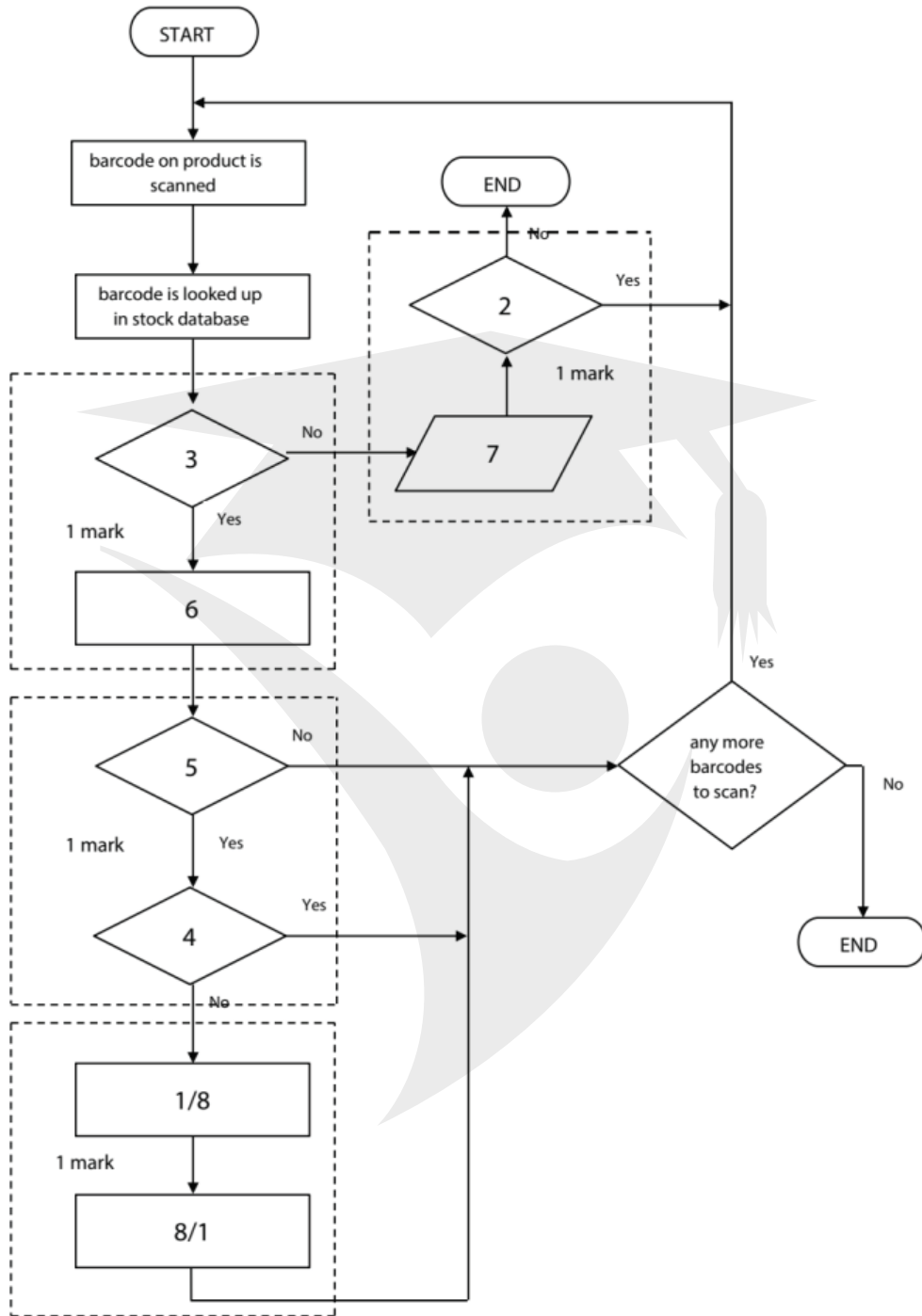

- 8 1 mark for each step in correct order. (NOTE: Marks can be awarded for a correct se

Steps in the printing process	Step order
As the printing drum rotates, a laser scans across it; this removes the positive charge in certain areas	4
The printing drum is coated in positively-charged toner; this then sticks to the negatively-charged parts of the printing drum	6
The paper goes through a fuser which melts the toner so it fixes permanently to the paper	9
The printer driver ensures that the data is in a format that the laser printer can understand	(1)
A negatively-charged sheet of paper is then rolled over the printing drum	7
Data is then sent to the laser printer and stored temporarily in the printer buffer	2
The toner on the printing drum is now transferred to the paper to reproduce the required text and images	8
The printing drum is given a positive charge	3
Negatively-charged areas are then produced on the printing drum; these match exactly with the text and images to be printed	5

Q 4) Winter 2015 P13

- 1 (a) Temperature
- central heating / air con system
 - greenhouse environment
 - a chemical reaction / process
- Magnetic field
- anti-lock brakes on a car
 - detection of motor vehicles (e.g. at traffic lights)
 - reading magnetic ink characters on cheques
 - geophysical surveys
- Motion
- automatic doors
 - burglar alarm

(b)

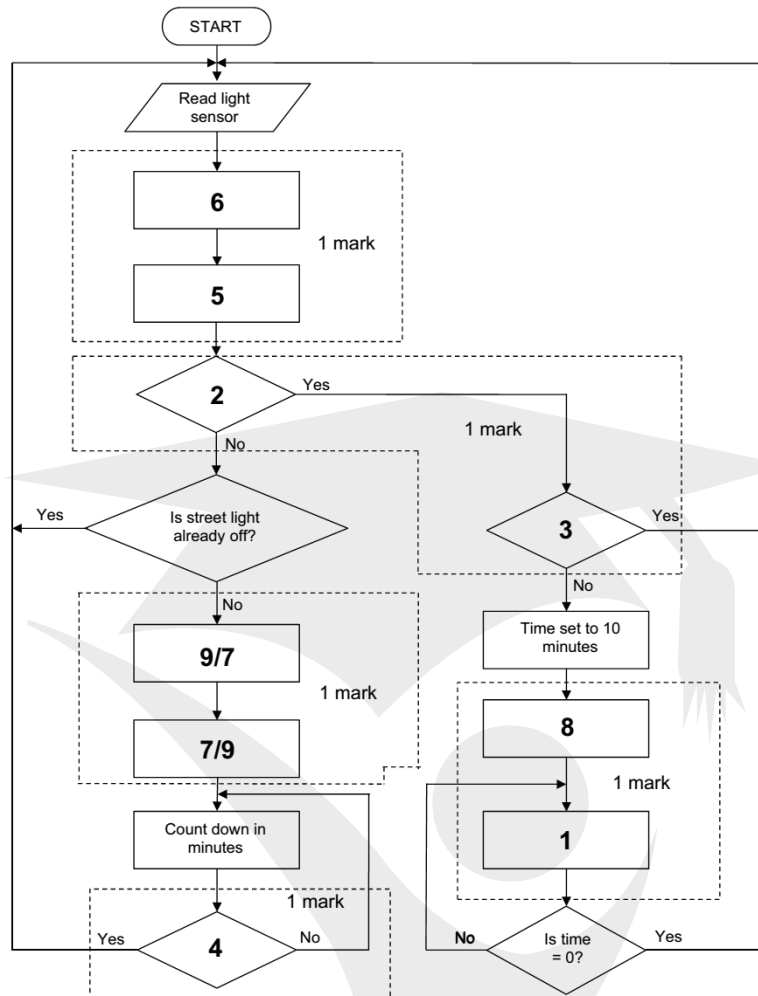

- 6 Any **two** from:
- facial recognition software/biometric software used to scan face
 - face image converted to digital format/data by the camera
 - digital image formed from scanned photo/biometric data stored in passport
 - key features of the face are checked/compared

7

Application	Suitable output device
Production of one-off photographs of very good quality	inkjet printer
High volume colour printing of advertising flyers	laser printer
Production of an object, which is built up layer by layer; used in CAD applications	3D printer
Converting electrical signals into sound	speaker/headphones
Showing enlarged computer output on a wall or large screen	Projector

8 1 mark for each named application + 1 mark for each matching reason for choice

Input device	Application and reason
Light sensor	Automatic doors – detects a person when light beam broken and opens doors Street lighting – detects change in light and switches on/off the street lights Greenhouse – ensures correct lighting conditions for growth of plants
Keyboard	Word processor / spreadsheet / database – need to key in data manually (e.g. report writing) Control room interface – need to manually key in data (e.g. flow speed of liquid)
Barcode reader	Supermarket checkout – read barcodes to find prices, description – allows automatic stock control Library system – can track books on loan – can link books to borrowers using barcoded cards Airport check-ins – barcodes on luggage to track whereabouts
Touch screen	Ticket/information kiosk – easy method for public to enter data – limited number of options Mobile phone/tablet – easy method to input data – use of icons for application selection Control room interface – faster/easier method to input data into system – fewer chances of error since number of choices limited

Q 5) Winter 2015 P11

5 (a) (i) Inkjet printer

Any **four** from:

- uses cartridges/liquid ink
- makes use of thermal bubble/piezoelectric technology
- sprays ink in droplets on the paper
- uses a moving print head
- suitable for low volume (high quality) output, e.g. a photo

(ii) Laser printer

Any **four** from:

- uses powdered ink/toner cartridges
- uses a (charged) printing drum
- makes use of static electricity charges
- uses a fuser to fix/melt ink onto the paper
- uses a discharge lamp to remove static charge from the drum
- useful for high volume (high quality) output, e.g. leaflets

(b) Any **three** from:

- produces solid, 3D objects/prototypes
- used in CAD/CAM
- makes use of tomography/slices of an object
- solid built up in thin layers
- uses resin, powdered metal, paper, plastic...

1 (a) 1 mark for each name of application + 1 mark for description of use

Hardware item	Application and how the hardware item is used
Barcode reader	Supermarket checkout <ul style="list-style-type: none"> - read barcodes to find prices, description - allows automatic stock control Library system <ul style="list-style-type: none"> - can track books on loan - can link books to borrowers using barcoded cards Airport checkouts <ul style="list-style-type: none"> - barcodes on luggage to track whereabouts
Microphone	Voice recognition system <ul style="list-style-type: none"> - allows computer to recognise spoken words and use them as input to, e.g., a word processor Multimedia presentations <ul style="list-style-type: none"> - allows voice-overs on presentations Video conferencing/VoIP <ul style="list-style-type: none"> - allows users to speak to each other
Touch screen	Mobile telephone/tablet <ul style="list-style-type: none"> - allows user to select apps/icons - easy method to input data Ticket/information kiosk <ul style="list-style-type: none"> - limits the options available for ease of use
Infrared sensor	Burglar/intruder detection system <ul style="list-style-type: none"> - detects presence of a person by breaking beam/change of temperature Automatic doors <ul style="list-style-type: none"> - breaking i/r beam allows detection of person approaching door Counting, e.g. people/cars <ul style="list-style-type: none"> - every time beam is broken it can automatically send data and allow automatic counting

11 1 mark for each input device + 1 mark for correct MATCHING reason for each device

Input Devices

- Barcode scanner
- ... to scan the barcode on boarding pass/mobile phone screen
- keyboard
- ... to key in data in case barcode fails to scan
- (electronic) scales
- ... weigh luggage at check-in

1 mark for each output device + 1 mark for correct MATCHING reason for each device

Output Devices

- beeper/speaker
- ... confirm barcode read/indicate error if barcode not read
- (LCD) screen
- ... select options (e.g. airline) at check-in
- printer
- ... produce bag labels

Q 6) Summer 2016 P11 & P13

Page 3	Mark Scheme	Syllabus	Paper
	Cambridge O Level – May/June 2016	2210	11

3 (a)

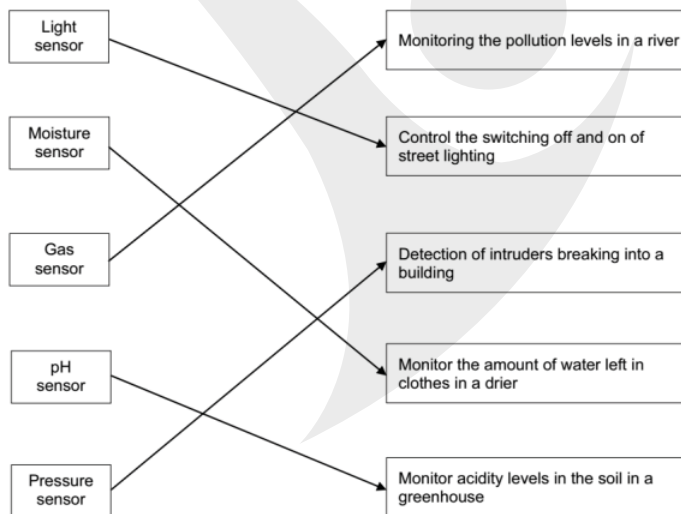

- 4/5 matches – 4 marks
- 3 matches – 3 marks
- 2 matches – 2 marks
- 1 match – 1 mark

[4]

(b) Any four from:

- sensor(s) sends signal/data to microprocessor
- signal/data converted to digital (using an ADC)
- microprocessor compares signal/data with pre-set/stored value
- if sensor(s) signal/data indicates the presence of a person / the door needs to be opened / a match is found / door is closed ...
- ... microprocessor sends a signal to an actuator ...
- ... to operate/drive a motor to open the door

[4]

Page 4	Mark Scheme	Syllabus	Paper
	Cambridge O Level – May/June 2016	2210	11

4 (a) (i) serial [1]

- (ii) Any **three** from:
- automatically detects the hardware/installs drivers
 - plug only goes in one way/can't connect incorrectly
 - supports different data transmission speeds/a range of data transmission speeds
 - has become the industry standard/universally used
 - backwards compatible (with earlier versions of USB ports)
- [3]

(iii) interrupt [1]

(b) 1 mark each use of printer, max 1 mark per printer.

- | | | |
|----------------|--|-----|
| inkjet printer | <ul style="list-style-type: none"> - (small quantities of) documents - photographs | |
| 3D printer | <ul style="list-style-type: none"> - (physical) prototype (from CAD) - (physical) model (from a blueprint) | [2] |

(c) 1 mark for naming printer + 1 mark for description + 1 mark for application

- Laser printer
- uses toner/powder ink
 - uses (positive and negative) charged drums // rotating drum
 - uses static charge
 - no moving head
 - faster at printing
 - high volume output/high speed
 - producing flyers/leaflets/magazines
- [3]

This is an example, other types of printers can be credited.

Page 10	Mark Scheme	Syllabus	Paper
	Cambridge O Level – May/June 2016	2210	11

12 (a) QR (quick response) Code [1]

(b) - **A 5 0** (1 mark)



[4]

(c) Any **three** from:

- visitor scans the QR code with (the camera on) the mobile device
 - App is used to read/interpret the QR code
 - links to a website/opens a document ...
 - ... to access local tourist information
 - can store the QR code to refer to again for the information
- [3]

Q 11) Summer 2017 P11

Question	Answer	Marks
9	<p>1 mark for appropriate device name and 1 further mark for appropriate purpose.</p> <p>Input devices Two from:</p> <ul style="list-style-type: none"> ∞ Keypad / Keyboard ... ∞ ... e.g. to allow customer to input the quantity of an item ∞ Touchscreen ... ∞ ... e.g. to allow a customer to select a payment method ∞ Barcode scanner / Barcode reader ... ∞ ... e.g. to allow a customer to scan in their shopping ∞ Card reader // Cash deposit / intake ... ∞ ... e.g. to allow a customer to pay for their shopping ∞ Weighing scales ... ∞ ... e.g. to allow a customer to weigh fresh produce <p>Output devices One from:</p> <ul style="list-style-type: none"> ∞ Display / Touchscreen ... ∞ ... e.g. to allow a customer to see the running total of their shopping ∞ Speaker ... ∞ ... e.g. to give audio instructions to a customer about how to use the self-checkout ∞ Printer ... ∞ ... e.g. to print a receipt for the customer 	6

Q 9) Winter 2016 P11& 13

4 (a) Any **two** from:

- Easy to make a mistake
- Can be slow if not trained
- Dirt/food can get into keys

[2]

(b) Any **two** with identification and explanation from:

- Fewer typing errors may be made ...
- ... because one button is pressed to order an item
- Speed up the time to enter an order ...
- ... because fewer buttons are pressed to complete the order
- May require less training ...
- ... because it is easier to identify an order item from its image rather than typing it
- Can stop dirt/food damage ...
- ... normally has a protective layer // because there are no keys for dirt/food to get into

[4]

7 Any **four** from:

- reaches maximum brightness quickly
- colours are vivid
- good colour definition/contrast can be achieved
- screens can be thinner/thin
- more reliable as LED's are long lasting
- consume very little/less energy

[4]

9 Any **six** from:

- infrared / motion / pressure (sensor) // sensor detects movement/pressure
- signals/data sent (continuously) to microprocessor
- converted from analogue to digital (using ADC)
- microprocessor compares value with those stored in memory
- if sensor value does not match the stored value(s) ...
- ... signal sent to switch on the light
- ... signal sent to keep the light on
- ... light remains on for a period of time (30 seconds)
- if sensor value matches the stored value(s) ...
- ... light will remain off
- ... will turn off after period of time (30 seconds)
- works in a continues loop

[6]

Q 12) Summer 2017 P12

Question	Answer	Marks
<p>3</p> <div style="display: flex; flex-direction: column; gap: 10px;"> <div style="border: 1px solid black; padding: 5px; width: 100px; text-align: center;">Inkjet printer</div> <div style="border: 1px solid black; padding: 5px; width: 100px; text-align: center;">LCD screen</div> <div style="border: 1px solid black; padding: 5px; width: 100px; text-align: center;">2D cutter</div> <div style="border: 1px solid black; padding: 5px; width: 100px; text-align: center;">LED screen</div> <div style="border: 1px solid black; padding: 5px; width: 100px; text-align: center;">Laser printer</div> </div> <p>1 mark for each correct line to a max of 4 marks.</p>	<div style="display: flex; flex-direction: column; gap: 10px;"> <div style="border: 1px solid black; padding: 5px; width: 250px; text-align: center;">Flat panel display that uses the light modulating properties of liquid crystals.</div> <div style="border: 1px solid black; padding: 5px; width: 250px; text-align: center;">Flat panel display that uses an array of light-emitting diodes as pixels.</div> <div style="border: 1px solid black; padding: 5px; width: 250px; text-align: center;">Droplets of ink are propelled onto paper.</div> <div style="border: 1px solid black; padding: 5px; width: 250px; text-align: center;">Electrically charged powdered ink is transferred onto paper.</div> <div style="border: 1px solid black; padding: 5px; width: 250px; text-align: center;">High powered laser that uses the x-y plane.</div> </div>	<p>4</p>

Question	Answer	Marks
6	<p>1 mark for correct name of code, up to a further 3 marks for appropriate explanation</p> <ul style="list-style-type: none"> ∞ Quick response (QR) Code <p>Three from:</p> <ul style="list-style-type: none"> ∞ Barcode is captured / scanned / imaged, by a camera / scanner / barcode reader / QR code reader ∞ Read using a laser ∞ Processed by an app ∞ Light is reflected back ∞ Black squares reflect less light than white squares ∞ Modules are used for orientation / alignment ∞ Squares / data are decoded 	4

Q 15) March 2018 P12 (India)

Question	Answer	Marks
12(a)	<p>Quicker to scan rather than type into a system</p> <p>Fewer errors no human input</p>	4

Question	Answer	Marks
12(b)	<p>Any four from:</p> <p>Uses a barcode reader / scanner Reader shines light / red laser at barcode White lines reflect (more) light Sensors / photoelectric cells detect light reflected back Different reflections / bars will convert to different binary values</p>	4

Q 16) Summer 2018 P11

Question	Answer	Marks
1	<p>1 mark for each correct answer, in the given order:</p> <ul style="list-style-type: none"> - analogue - digital - denary - 10 - binary - 2 	6

Question	Answer	Marks
8(a)	<p>Any four from:</p> <ul style="list-style-type: none"> - Shines light / (red) laser at barcode - Light is called an illuminator - Light is reflected back // White lines reflect light // Black lines reflect less light/absorbs light - Sensors / photoelectric cells detect the light - Different reflections / bars will give different binary values / digital values // pattern converted to digital values - A microprocessor interprets the data 	4
8(b)	<p>Any three from:</p> <ul style="list-style-type: none"> - barcode identifies a (unique) product - barcode can be used to look up product (in a database) - data about stock levels can be stored on a system - stock can be automatically deducted from the system - can check stock is below a certain level // check stock level - automatic re-order // Alerts when stock is low - automatically update new stock level - to locate if an item of stock is available in another location 	3

Question	Answer	Marks
8(c)	Any four from: <ul style="list-style-type: none"> - (Infrared) rays are sent across screen (from the edges) - Has sensors around edge // Sensors capture beams - (Infrared) rays form a grid across the screen - (Infrared) ray is broken (by a finger blocking a beam) - Calculation is made (on where beam is broken) to locate the 'touch' // Co-ordinates are used to locate the touch 	4
8(d)	Secondary Storage – any two from: <ul style="list-style-type: none"> - Not directly accessed by the CPU - Non-volatile storage - Secondary is internal to the computer/device - An example of secondary storage would be HDD/SSD Off-line storage – any two from: <ul style="list-style-type: none"> - Non-volatile storage - Off-line storage is storage that is removable from a computer/device // not internal // portable - An example of off-line storage would be CD/DVD/USB stick/SD card/magnetic tape/ external HDD/SSD 	4

Q 17) Summer 2018 P12

2(a)	Any four from: <ul style="list-style-type: none"> - Image is converted from <u>analogue</u> to digital (using ADC) - Image is turned into pixels - Each pixel is given a binary value - Pixels form a grid (to create the image) - Each pixel has a colour - Pixels are stored in sequence (in a file) - Meta data is stored (to describe the dimensions/resolution of the image) // It stores the dimensions/colour depth .etc. - An example of a suitable photo file format e.g. JPEG 	4
9(a)	QR/Quick response	1
9(b)	Any four from: <ul style="list-style-type: none"> - Read/scanned using app (on mobile device) - It is the camera that is used to scan/capture the image - The three large squares are used to define the alignment // uses alignment targets/modules - Black squares reflect less light // white squares reflect more light - The app/device processes the image - Each small square/pixel is converted to a binary value 	4
10(a)	Any four from: <ul style="list-style-type: none"> - Conductive layer - An electrostatic/electric field is created - Sensor(s) (around the screen) monitor the electrostatic field - When touched (electrostatic) charge is transferred to finger - Location of touch is calculated // Co-ordinates used to calculate touch 	4
10(b)(i)	Any two from: <ul style="list-style-type: none"> - Gloves are not conductive // Gloves are an insulator - Block current/charge from finger / body / person - Stop the electrostatic field being disturbed/changed 	2
10(b)(ii)	Any two from e.g. (1 mark for method, 1 for expansion): <ul style="list-style-type: none"> - She could use a (conductive) stylus... - ... this will allow the charge to be charged/disturbed - She could use capacitive gloves... - ... this will allow the charge to be charged/disturbed - She could use a natural language interface/voice operated interface ... - ... she could give vocal commands to the device 	2

Q 18) Winter 2018 P12

Question	Answer	Marks
5(a)(i)	<u>2D/3D</u> cutter	1
5(a)(ii)	Liquid crystal display // LCD	1
5(a)(iii)	Actuator	1
5(b)	1 mark for each correct missing word, in the given order: <ul style="list-style-type: none"> ∞ interactive whiteboard ∞ inkjet ∞ thermal bubble ∞ laser ∞ rotating 	5



Q 19) Winter 2018 P13

Question	Answer	Marks														
1	1 mark for each correct line, maximum 5 marks	5														
	<table border="1"> <thead> <tr> <th>Device</th> <th>Description</th> </tr> </thead> <tbody> <tr> <td>Laser Printer</td> <td>Uses a high-intensity beam of light shone through three layers of changing pixels</td> </tr> <tr> <td>LCD Projector</td> <td>Uses millions of micro mirrors to reflect light through a lens</td> </tr> <tr> <td>Digital Light Projector (DLP)</td> <td>Uses plastic, resin or powdered metal to generate a physical output</td> </tr> <tr> <td>Inkjet Printer</td> <td>Uses a static electric charge on a rotating drum to generate a physical output</td> </tr> <tr> <td>3D Printer</td> <td>Uses liquid ink to generate a physical output</td> </tr> <tr> <td>2D Cutter</td> <td>Uses a high-power laser to generate a physical output</td> </tr> </tbody> </table>	Device	Description	Laser Printer	Uses a high-intensity beam of light shone through three layers of changing pixels	LCD Projector	Uses millions of micro mirrors to reflect light through a lens	Digital Light Projector (DLP)	Uses plastic, resin or powdered metal to generate a physical output	Inkjet Printer	Uses a static electric charge on a rotating drum to generate a physical output	3D Printer	Uses liquid ink to generate a physical output	2D Cutter	Uses a high-power laser to generate a physical output	
Device	Description															
Laser Printer	Uses a high-intensity beam of light shone through three layers of changing pixels															
LCD Projector	Uses millions of micro mirrors to reflect light through a lens															
Digital Light Projector (DLP)	Uses plastic, resin or powdered metal to generate a physical output															
Inkjet Printer	Uses a static electric charge on a rotating drum to generate a physical output															
3D Printer	Uses liquid ink to generate a physical output															
2D Cutter	Uses a high-power laser to generate a physical output															

Q 20) March 2019 P12

2(a)(i)	- (A device that allows) data to be entered (into a computer system)	1
2(a)(ii)	One from e.g.: - Keyboard - Mouse - Microphone - Sensor - Touch screen	1
2(b)(i)	- (A device that allows the user to) view/hear the data (that has been entered into a computer system)	1
2(b)(ii)	One from e.g. : - Monitor - Speaker - Headphones - Printer	1

Q 21) Summer 2019 P11

3	1 mark for each correct device	5												
	<table border="1"> <thead> <tr> <th>Description of input or output device</th> <th>Name of device</th> </tr> </thead> <tbody> <tr> <td>This is an input device that works by shining a light onto the surface of a document. The light source is automatically moved across the document and the reflected light is captured by mirrors and lenses.</td> <td>2D Scanner</td> </tr> <tr> <td>This is an input device where a laser or a light source is moved across an object. The width, height and depth of the object are measured to allow a model to be created.</td> <td>3D scanner</td> </tr> <tr> <td>This is a large input device that is usually fixed to a wall. A user can calibrate the device to make sure the sensors align with a projected image. The user can use either their finger or a special pen to make selections.</td> <td>Interactive whiteboard</td> </tr> <tr> <td>This is an output device that uses many small mirrors to reflect light towards a lens. This will display an image.</td> <td>Projector</td> </tr> <tr> <td>This is an output device that creates an object by building layer upon layer of material.</td> <td>3D printer</td> </tr> </tbody> </table>	Description of input or output device	Name of device	This is an input device that works by shining a light onto the surface of a document. The light source is automatically moved across the document and the reflected light is captured by mirrors and lenses.	2D Scanner	This is an input device where a laser or a light source is moved across an object. The width, height and depth of the object are measured to allow a model to be created.	3D scanner	This is a large input device that is usually fixed to a wall. A user can calibrate the device to make sure the sensors align with a projected image. The user can use either their finger or a special pen to make selections.	Interactive whiteboard	This is an output device that uses many small mirrors to reflect light towards a lens. This will display an image.	Projector	This is an output device that creates an object by building layer upon layer of material.	3D printer	
Description of input or output device	Name of device													
This is an input device that works by shining a light onto the surface of a document. The light source is automatically moved across the document and the reflected light is captured by mirrors and lenses.	2D Scanner													
This is an input device where a laser or a light source is moved across an object. The width, height and depth of the object are measured to allow a model to be created.	3D scanner													
This is a large input device that is usually fixed to a wall. A user can calibrate the device to make sure the sensors align with a projected image. The user can use either their finger or a special pen to make selections.	Interactive whiteboard													
This is an output device that uses many small mirrors to reflect light towards a lens. This will display an image.	Projector													
This is an output device that creates an object by building layer upon layer of material.	3D printer													

Q 22) Summer 2019 P12

1(a)	Three from e.g.: <ul style="list-style-type: none"> - Keyboard - Mouse - Microphone - 2D scanner - 3D scanner - Touchscreen - Webcam // digital camera - Joystick - Trackpad - Sensor - Interactive whiteboard 	3
1(b)	Three from e.g.: <ul style="list-style-type: none"> - Monitor // touchscreen - Inkjet printer - Laser printer - 3D printer - Speaker - Headphones - LED Projector - DLP - 2D cutter - 3D cutter - Actuator 	3
4(b)(ii)	Four from: <ul style="list-style-type: none"> - Rollers are used to move the paper through the printer - Nozzles spray/drop/jet ink onto the paper - Ink jets/print head/nozzles are moved across the paper (to distribute the ink) - Different colour inks are mixed to create required colours - Technology could be piezoelectric - Technology could be thermal bubble - Ink is heated - ... and expands/evaporates into a bubble - Bubble is pushed through the nozzle on to the paper - ... then the bubble collapses - Electrical current is applied to a crystal - ... which makes it vibrate - ... which forces a droplet of ink through the nozzle 	4
10	Four from: <ul style="list-style-type: none"> - Electrical field/charge is spread across the screen - Sensors are located around the screen // sensors are used to read the electric field - When finger touches screen, the charge/ is transferred to the user - ... as it is affected by the conductivity of another object - Coordinates of touch determined/calculated/measured 	4

Q 23) Winter 2019 P13

2210/13

Cambridge O Level – Mark Scheme
PUBLISHED

October/November 2019

Question	Answer	Marks
1(a)(i)	Two from: ∞ 2D scanner ∞ Touchscreen ∞ Keypad/keyboard ∞ Card reader ∞ Mouse ∞ Digital camera	2
1(a)(ii)	Two from: ∞ HDD ∞ SSD ∞ USB flash memory drive ∞ SD card ∞ Any optical	2
1(a)(iii)	Two from: ∞ Monitor/Touch screen ∞ Speaker ∞ Printer ∞ LED // Light	2
1(b)(i)	∞ Increase the length of the key // make key 12-bit, etc.	1
1(b)(ii)	∞ Cypher text	1
1(d)	Five from: ∞ The display is made up of pixels ... ∞ ... that are arranged together as a matrix ∞ Each pixel has three filters, red, blue and green ∞ Shades of colour are achieved by mixing red, blue and green ∞ The screen is backlit ∞ Light is shone through the liquid crystals ∞ The liquid crystals can be made to turn solid or transparent/on or off ... ∞ ... by changing the shape of the crystal	5

Q 24) Winter 2019 P12

6	One mark for each correct tick	6																					
	<table border="1"> <thead> <tr> <th>Statement</th> <th>Resistive (✓)</th> <th>Capacitive (✓)</th> </tr> </thead> <tbody> <tr> <td>This touch screen has multi-touch capabilities</td> <td></td> <td>✓</td> </tr> <tr> <td>This touch screen cannot be used whilst wearing gloves</td> <td></td> <td>✓</td> </tr> <tr> <td>This touch screen is made up of two layers with a small space in between</td> <td>✓</td> <td></td> </tr> <tr> <td>This touch screen uses the electrical properties of the human body</td> <td></td> <td>✓</td> </tr> <tr> <td>This touch screen is normally cheaper to manufacture</td> <td>✓</td> <td></td> </tr> <tr> <td>This touch screen has a quicker response time</td> <td></td> <td>✓</td> </tr> </tbody> </table>	Statement	Resistive (✓)	Capacitive (✓)	This touch screen has multi-touch capabilities		✓	This touch screen cannot be used whilst wearing gloves		✓	This touch screen is made up of two layers with a small space in between	✓		This touch screen uses the electrical properties of the human body		✓	This touch screen is normally cheaper to manufacture	✓		This touch screen has a quicker response time		✓	
Statement	Resistive (✓)	Capacitive (✓)																					
This touch screen has multi-touch capabilities		✓																					
This touch screen cannot be used whilst wearing gloves		✓																					
This touch screen is made up of two layers with a small space in between	✓																						
This touch screen uses the electrical properties of the human body		✓																					
This touch screen is normally cheaper to manufacture	✓																						
This touch screen has a quicker response time		✓																					

Q 26) Summer 20 P12

6	Statement	Capacitive (✓)	Resistive (✓)	6
	Needs pressure to be applied to create a circuit		✓	
	May not register a touch if the user is wearing gloves	✓		
	More commonly used in smartphones	✓		
	More responsive to a touch	✓		
	Needs an electrical field to be changed to register a touch	✓		
	Cheaper to manufacture		✓	
One mark per correct tick				

8(a)	Any three from: <ul style="list-style-type: none"> - It is a universal standard - It can't be inserted the wrong way around - Supports different transmission speeds - Automatically detects if correct driver installed 	3
8(b)	Two marks for benefits, one mark for drawback Benefits: <ul style="list-style-type: none"> - Faster speed of printing - Can print duplex / on both sides - Many letters can be printed from one toner cartridge - Can print in high volumes Drawback <ul style="list-style-type: none"> - Toner cartridge more expensive to buy - More time to warm-up - Larger footprint 	3

2210/12

Cambridge O Level – Mark Scheme
PUBLISHED

May/June 2020

Question	Answer	Marks
8(c)(i)	Any two from: <ul style="list-style-type: none"> - Paper jam - Out of paper - Out of toner/ink - Buffer full - Awaiting input - Print complete - Printer ready Award any other valid example	2
8(c)(ii)	Any one from: <ul style="list-style-type: none"> - Operating system - Interrupt handler - Interrupt service routine 	1

Q 27) 15a Summer 20 P11

Question	Answer	Marks
1(a)	Any one from: - Microphone - Touchscreen - Camera - Button	1
1(b)	Any two from: - Speaker - Touchscreen - Light/flash	2

6	Sensor	Scenario	4
	Pressure / motion / infra-red	Detecting when a person is approaching an automatic door system	
	pH / light	Monitoring the pollution level in a river	
	Temperature	Checking if a tropical aquarium is 25 degrees Celsius	
	Magnetic field / pressure / motion / infra-red	Counting the number of cars that cross a bridge	

One mark per each correct sensor (each sensor must be different)

8(a)	- Interrupt	1
------	-------------	---

8(b)	<p>One mark for benefit, two marks for drawbacks</p> <p>Benefit:</p> <ul style="list-style-type: none"> - Printing may be higher quality - Can use larger paper sizes - Can print onto different media - No warm-up time <p>Drawbacks:</p> <ul style="list-style-type: none"> - Printing will be slower - Ink is more expensive per page - Ink can be smeared // ink is not smudge proof 	3
------	---	---

8(c)	Statement	Inkjet (✓)	Laser (✓)	4
	Uses a rotating drum to transfer the image to the paper		✓	
	Uses powdered toner		✓	
	Uses nozzles to spray droplets on to the paper	✓		
	Uses a print head mechanism that moves side to side	✓		

One mark per each correct row

Q 28) Winter 20 P12

5(a)	<p>One mark for each correct row:</p> <table border="1"> <thead> <tr> <th>Statement</th> <th>True (✓)</th> <th>False (✓)</th> </tr> </thead> <tbody> <tr> <td>It is a flat panel display</td> <td>✓</td> <td></td> </tr> <tr> <td>It creates images using red, green and blue diodes</td> <td>✓</td> <td></td> </tr> <tr> <td>It is not very energy efficient and gives off heat</td> <td></td> <td>✓</td> </tr> <tr> <td>It is also used in mobile devices such as smartphones and tablets</td> <td>✓</td> <td></td> </tr> <tr> <td>It is a front-lit display</td> <td></td> <td>✓</td> </tr> </tbody> </table>	Statement	True (✓)	False (✓)	It is a flat panel display	✓		It creates images using red, green and blue diodes	✓		It is not very energy efficient and gives off heat		✓	It is also used in mobile devices such as smartphones and tablets	✓		It is a front-lit display		✓	5
Statement	True (✓)	False (✓)																		
It is a flat panel display	✓																			
It creates images using red, green and blue diodes	✓																			
It is not very energy efficient and gives off heat		✓																		
It is also used in mobile devices such as smartphones and tablets	✓																			
It is a front-lit display		✓																		

Q 29) Winter 20 P13

1	<p>One mark for each correct row:</p> <table border="1" data-bbox="256 309 796 607"> <thead> <tr> <th>Device</th> <th>Input (✓)</th> <th>Output (✓)</th> <th>Storage (✓)</th> </tr> </thead> <tbody> <tr> <td>Solid state drive (SSD)</td> <td></td> <td></td> <td>✓</td> </tr> <tr> <td>Headphones</td> <td></td> <td>✓</td> <td></td> </tr> <tr> <td>2D cutter</td> <td></td> <td>✓</td> <td></td> </tr> <tr> <td>LCD projector</td> <td></td> <td>✓</td> <td></td> </tr> <tr> <td>Microphone</td> <td>✓</td> <td></td> <td></td> </tr> </tbody> </table>	Device	Input (✓)	Output (✓)	Storage (✓)	Solid state drive (SSD)			✓	Headphones		✓		2D cutter		✓		LCD projector		✓		Microphone	✓			5
Device	Input (✓)	Output (✓)	Storage (✓)																							
Solid state drive (SSD)			✓																							
Headphones		✓																								
2D cutter		✓																								
LCD projector		✓																								
Microphone	✓																									
8(a)	<p>Any three from:</p> <ul style="list-style-type: none"> - Liquid crystal display - The display is made of pixels - ... arranged in a matrix - Uses a flat panel display - Backlit display - ... with CCFLs/LEDs - Uses light-modulating properties of liquid crystals - Crystals can be turned between opaque and transparent (to allow light to pass) - Colours created using RGB 	3																								
8(b)	<p>Any three from:</p> <ul style="list-style-type: none"> - Low power consumption - Runs at cool temperature - Do not suffer image burn - Do not suffer flicker issues - Bright image/colours - High resolution image - Cheaper to purchase than e.g. LED screen 	3																								
11	<p>Six from:</p> <ul style="list-style-type: none"> - Suitable sensor used e.g. motion sensor/pressure sensor - (Analogue) data is converted to digital (using ADC) - Sensor sends data to microprocessor - Data compared to stored data ... - ... if value outside range/within range water is sprayed - ... signal sent to actuator to spray water - ... if value within range/outside range no action taken - Continuous loop 	6																								

Q 30) March 21 P12

3	<p>One mark for each device/description</p> <table border="1"> <thead> <tr> <th data-bbox="336 288 568 387">Name of device</th> <th data-bbox="568 288 1302 387">Description</th> </tr> </thead> <tbody> <tr> <td data-bbox="336 387 568 477">Inkjet Printer</td> <td data-bbox="568 387 1302 477">Uses either thermal bubble or piezoelectric technology</td> </tr> <tr> <td data-bbox="336 477 568 611">Actuator</td> <td data-bbox="568 477 1302 611">– Operated by signals to cause a physical movement Controls the movement of a machine // by example</td> </tr> <tr> <td data-bbox="336 611 568 712">DLP//Projector</td> <td data-bbox="568 611 1302 712">Uses thousands of tiny mirrors that can move very quickly to create an image</td> </tr> <tr> <td data-bbox="336 712 568 949">Mouse</td> <td data-bbox="568 712 1302 949"> <ul style="list-style-type: none"> – Uses rolling ball / optical sensor / laser to detect motion // by example – Movement echoed on screen // moves cursor/pointer (on screen) – Has scroll wheel / Buttons to allow data input // by example </td> </tr> </tbody> </table>	Name of device	Description	Inkjet Printer	Uses either thermal bubble or piezoelectric technology	Actuator	– Operated by signals to cause a physical movement Controls the movement of a machine // by example	DLP//Projector	Uses thousands of tiny mirrors that can move very quickly to create an image	Mouse	<ul style="list-style-type: none"> – Uses rolling ball / optical sensor / laser to detect motion // by example – Movement echoed on screen // moves cursor/pointer (on screen) – Has scroll wheel / Buttons to allow data input // by example 	4
Name of device	Description											
Inkjet Printer	Uses either thermal bubble or piezoelectric technology											
Actuator	– Operated by signals to cause a physical movement Controls the movement of a machine // by example											
DLP//Projector	Uses thousands of tiny mirrors that can move very quickly to create an image											
Mouse	<ul style="list-style-type: none"> – Uses rolling ball / optical sensor / laser to detect motion // by example – Movement echoed on screen // moves cursor/pointer (on screen) – Has scroll wheel / Buttons to allow data input // by example 											
4(a)	<p>Six from Max four from:</p> <ul style="list-style-type: none"> – Scanned using a barcode reader – Shines (red) laser/light – Light is reflected back // white lines reflect light // black lines reflect less light – Sensors/photoelectric cells detect the light – Different reflections/bars give different binary/digital values // (pattern) converted to binary/digital values – Microprocessor interprets the data – Uses check digit error checking <p>Max three from:</p> <ul style="list-style-type: none"> – Database stores data/barcodes/products/prices – Barcode/value/key transmitted to database/system // Searches for barcode/value/key in the database/system... – ... price is returned/found 	6										

Page | 224

4 A supermarket sells many products. Each product has a barcode.

(a) Explain how the barcode is read at the supermarket checkout and how the price of the product is found.

.....

.....

.....

.....

.....

.....

.....

.....

.....

.....

.....

.....

.....

[6]

Summer 21 P12

8 A keyboard is a type of input device that can be used to enter data into a computer.

Complete the paragraph that describes one method of operation for a keyboard, using the most appropriate terms from the given list. Not all terms in the list need to be used.

- Binary • Breaks • Calculated • Character • Circuit • Current
- Information • Network • Press • Processor • Signal • Switch

A keyboard has a key matrix underneath the keys. When a key is pressed, it presses

a that completes a This

allows to flow. The location of the key pressed

is The location of the key pressed is compared to

a map to find the value for the key that has been pressed.

[6]

Chapter 6

1.3.5 Storage Devices

Storage Media & Devices

The device that actually holds the data is known as the **storage medium** ('media' is the plural).

The device that saves data onto the storage medium, or reads data from it, is known as the **storage device**.

Storage Device: The machine which stores data on storage medium.



Storage Media: The physical material in which a devices stores data.

A computer holds programs and data in three sorts of device:

1. Primary — main memory, stores data and instructions to be directly accessed by processor. It has a limited-capacity but rapid-access during processing
2. Secondary — main storage, stores all data and programs. It has larger-capacity but slower-access. They remain inside computer.
3. Off-line — back-up storage, portable, they are removed after read/write data. stores data/programs for future use.

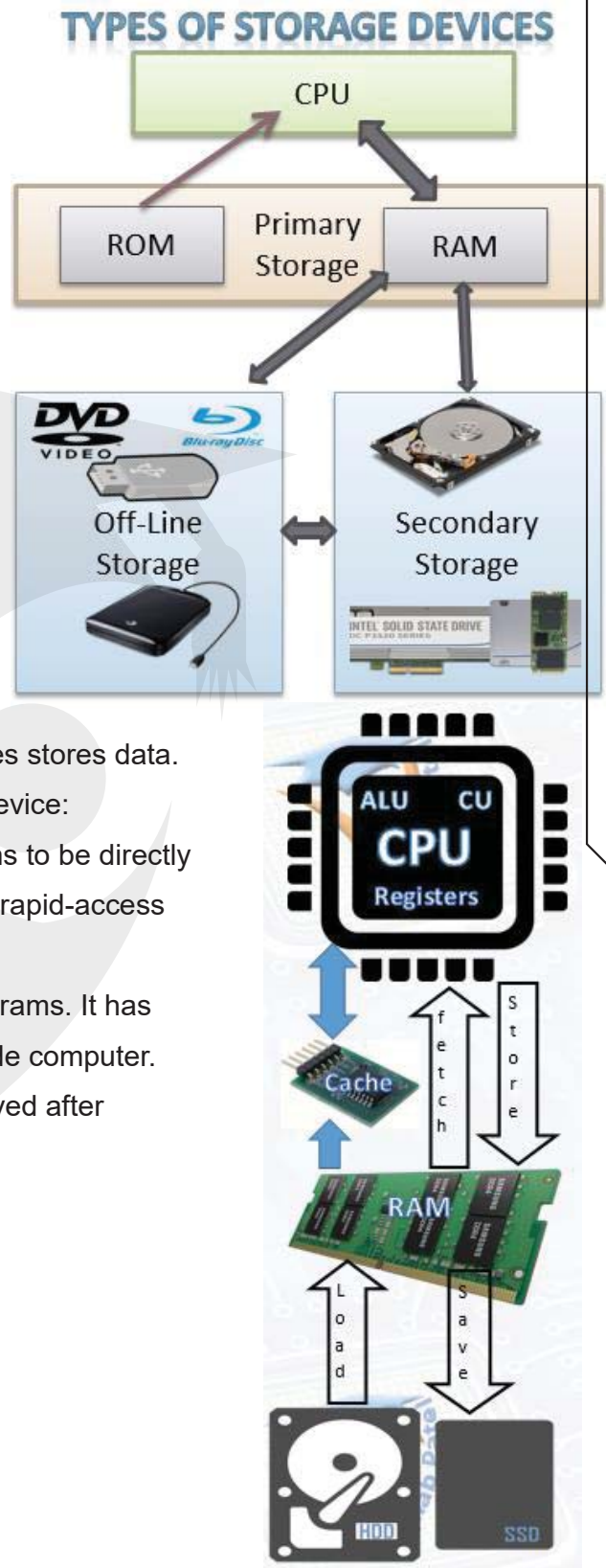

All data and programs are stored in secondary storage. They are loaded in primary storage so as processor can read it. The results of processing is firstly stored by processor in memory and then saved in secondary storage.

Primary memory

Data stored in primary memory can be accessed quickly and directly by the computer's processor. Primary storage is a computer's internal storage. It is in this storage where data is held ready for processing.

Primary memory is also known as 'primary storage' or 'memory'.

Its capacity of primary memory is quite small.

Primary storage is separated into Random Access Memory (RAM) and Read Only Memory (ROM).

Primary memory consists of:

- Non-volatile, read-only memory (ROM) to hold a small program to start up computer, BIOS, firmware, permanent
- volatile, read-write, random access memory (RAM) to hold the programs and data currently being processed, user memory, temporary

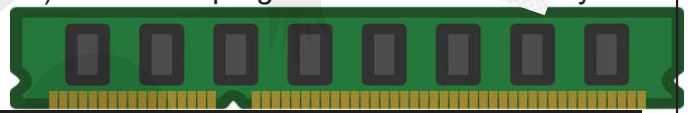

Differences between RAM and ROM

	RAM	ROM
Applications What they contain?	<ul style="list-style-type: none"> • Part of Operating system • Currently in use data programs. 	<ul style="list-style-type: none"> • A program used to start the computer called the 'Start-up routine' or BIOS. • Factory setting such as remote control frequencies • stores the set of routines; for example, how the buttons embedded system work
Can the contents be changed? (Is it volatile?)	Yes. The contents of the RAM are changed all the time while the computer is running. It is temporary.	No. The contents of ROM cannot normally be changed. It is permanent.
Who can store data	User	Manufacturer
Volatile or Non-volatile	It is volatile, i.e. it needs continuous power supply to retain data.	It is non-volatile i.e. it can retain data even when there is no power supply.

ROM

ROM stands for **Read Only Memory**. The memory from which we can only read but cannot write on it. This type of memory is non-volatile. The information is stored permanently in such memories during manufacture. A ROM stores such instructions that are required to start a computer. This operation is referred to as **bootstrap**. ROM chips are not only used in the computer but also in embedded systems like washing machine and microwave oven.

Types of ROM

Here are the various types of ROMs and their characteristics.



ROM:	Read Only Memory
PROM:	Programmable ROM
EPROM:	Erasable Programmable ROM
EEPROM:	Electrically Erasable PROM

ROM (or Masked ROM)

The very first ROMs were hard-wired devices that contained a pre-programmed set of data or instructions.

PROM (Programmable Read Only Memory) It can be programmed only once and is not erasable.

EPROM (Erasable and Programmable Read Only Memory)

It can be programmed and erased several times by exposing it to ultra-violet light.

EEPROM (Electrically Erasable and Programmable Read Only Memory)

EEPROM is programmed and erased electrically several time.

Advantages of ROM

The advantages of ROM are as follows :

- Non-volatile in nature
- Cannot be accidentally changed
- Cheaper than RAMs
- Easy to test
- More reliable than RAMs
- Static and do not require refreshing

RAM

RAM Stands for Random Access Memory. It is the essential part of every computer.

It is **Random** because its contents can be accessed randomly.

It is **Access** memory because user can load contents in it, can modify its contents and can erase.

It is **volatile**, it loses all its contents when computer is switched off.

There are two different types of RAM, Static & Dynamic

SRAM	DRAM
SRAM consists of a number of complex circuits (NAND or NOR). Each circuit stores one bit of data (0 or 1).	DRAM consists of <ul style="list-style-type: none"> capacitors to hold bit of data (0 or 1) and transistors to change capacitors' value like a switch.
NAND and NOR gates never leaks charge so SRAM does not need to be refreshed again and again.	Capacitors leaks charge with passage of time so DRAM requires data to be refreshed periodically in order to retain the data.
requires less power consumption	requires higher power consumption which is significant when used in battery-powered devices
used predominantly in cache memory of processors where speed is important	Commonly used in RAM
Has lesser storage capacity	has higher storage capacity
More expensive	less expensive

Secondary Storage

The main storage of computer where all data and programs are saved in the secondary storage.

Secondary storage devices are non-volatile. They can retain data even when computer is switched off. Their storage capacity is much larger than primary memory RAM while access speed is slower.

Secondary storage includes:

- Hard disks drive (HDD)
- Solid-state drive (SSD)

Hard drive read/write head

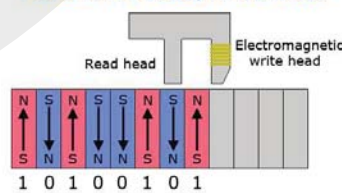

Internal Operation of Hard Disk Drive

S No	Step
	The hard disk has one or more platters made of aluminium or glass
	Each surface of the platter/disk is ferrous-oxide which is capable of being magnetised
	The disks are rotated at high-speed
	Each surface of the disk has a read/write head mounted on an arm positioned just above the surface
	Electronic circuits control the movement of the arm and hence the heads
	The surface of the platter/disk is divided into concentric tracks and sectors
	One track in one sector is the basic unit of storage called a block
	The data is encoded as a magnetic pattern for each block

	When writing to disk, a variation in the current in the head produces a variation in magnetic field on the disk
	When reading from disk, a variation in magnetic field produces a variation in current through the head

Uses

- Fixed hard drives are used to store the operating system and working data.
- They are used for storing applications software that needs fast retrieval and storage of data.
- Real-time systems (e.g. robots, control of a chemical plant) and online systems (e.g. booking airline tickets, automatic stock control (using EPOS)) used fixed hard drives.
- They are used in file servers for computer networks.

Solid State Drive (SSD)

Solid State Devices uses NAND or NOR chips, by movements of electrons.

These are non-volatile memory.

The term 'solid-state' essentially means 'no moving parts'.

Solid-state storage devices are based on **electronic circuits with no moving parts** (no reels of tape, no spinning discs, no laser beams, etc.), so the issue of **LATENCY** is removed. All data is retrieved at the same rate.

Many of our digital devices (**cameras, mobile phones, MP3 players, etc.**) require **compact, non-volatile** data storage. Flash memory cards provide this and come in a variety of shapes and sizes.



How SSD works

SSD uses NAND or NOR flash memory. It stores data in individual memory cells, using memory transistor. Each transistor composed of:

- a Control Gate, the top layer of transistor.
- A floating gate, the lower segment

The control gate attracts electrons and trapped some of them within floating gate, if electrons are trapped in floating gate, this state is known as bit value 1, and it remain same even there is no power supply. To reset a high voltage is applied which removes the electrons from floating gate.

Attribute	NAND Solid state	NOR Solid State
Storage capacity	High	Low
Cost per bit	Less expensive	More expensive
Access	Allows blocks of data (512 bytes or more) to be read or erased.	Allows data to be read or erased in single bytes at a time.
Write speed	Good	
Read speed		Good
Main application	<p>File storage e.g. SSD & Flash memory</p> 	<p>Code execution e.g. EEPROM technology.</p> <p>EEPROM technology is used for some security gadgets, such as credit card, SIM card, key-less entry, etc.</p> 

Advantages of SSD over HDD

- they are more reliable (no moving parts to go wrong)
- they are considerably lighter (which makes them suitable for laptops)
- they don't have to 'get up to speed' before they work properly
- they have a lower power consumption
- they run much cooler than HDDs (these last two points again make them very suitable for laptop computers)
- because they have no moving parts, they are very thin
- data access is considerably faster than HDD.

SSD Endurance

Most solid state storage devices are conservatively rated at only 20 GB write operations per day over a three-year period – this is known as SSD endurance. **For this reason,** *SSD technology is not used in servers, for example, where a huge number of write operations take place every day. However, this issue is being addressed by a number of manufacturers to improve the durability of these solid-state systems.*

Off-line Storage

Offline storage refers to any storage medium that must be physically inserted into a system every time a user wants to access or edit data. Offline storage can be any type of internal or external storage that can easily be removed from the computer.

Offline storage is also known as removable storage and includes:

- Optical devices like CDs, DVDs
- Solid state USB memory sticks
- External Hard disk

Optical Storage Devices / Media

Optical storage devices save data as patterns of **dots** that can be read using **light**. A **laser beam** is the usual light source. The data on the storage medium is read by bouncing the laser beam off the surface of the medium. If the beam hits a PIT it is **reflected** back differently to how it would be if there was LAND. This difference can be detected, so the data can be read.

PITS can be created using the laser beam (for media that is **writable** such as CD-Rs). The beam is used in a high-power mode to actually mark the surface of the medium, making a PIT. This process is known as '**burning**' data onto a disc.

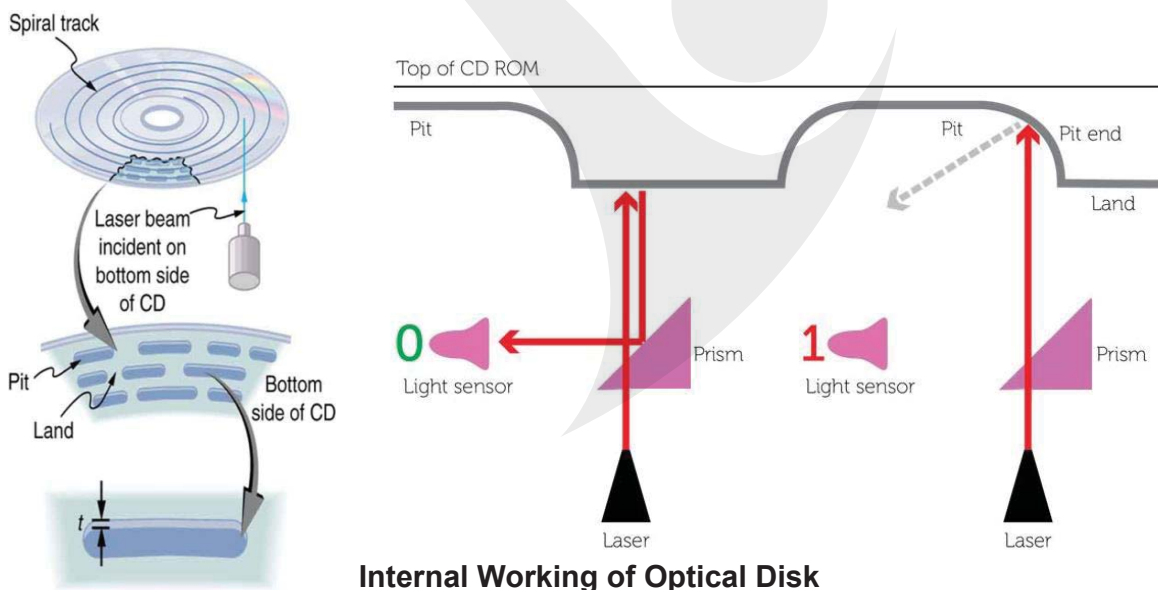

Internal Working of Optical Disk



- (Red) laser is used
- (Laser beams) shines onto surface of the disk
- It is rotated (at a constant speed) to be read
- Surface is covered in a track (that spirals from the centre)
- Data is represented on the surface using pits and lands
- Pits and lands represent binary values
- Pits reflect light back differently (to the area in between/land)
- Optical device can determine the binary value from the light reflection

The main types of CD and DVD have different suffixes, as follows:

- **ROM** stands for 'Read-Only Memory' – *suitable for distribution of movies and software etc.*
- **R** stands for 'Recordable' – these can be written to just once and then can only be read from, making them *suitable for archive copies of documents*
- **RW** stands for 'ReWritable' – these can be written to and read multiple times, making them *suitable for making temporary copies of data files for regular backup copies*

DVD-RAM is a DVD (optical disc) technology for high-capacity data storage for computers. Like ordinary random access memory ([RAM](#)), it can be repeatedly read, written to, and erased.

– **Blu-ray discs (BD or BR)** have larger storage capacities than other optical storage media and a higher rate of data transfer. Although disks are expensive, their cost per gigabyte of storage is nearer to that of a HDD. Differences between CDs, DVDs, DVD-RAM and Blu-Ray

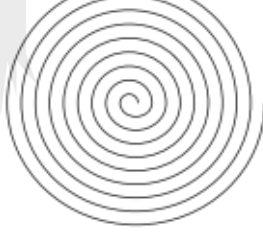
	CD	DVD	DVD-RAM	Blu-Ray
Track	Single Spiral Track 	Single Spiral Track 	Multiple Concentric Tracks 	Single Spiral Track 
Layer	Single polycarbonate layer	Double polycarbonate layer	Double polycarbonate layer	Single polycarbonate layer
	No birefringence as no sandwiched layers	Two sandwiched layers causes Birefringence (light is refracted into two separate beams causing reading errors)	Two sandwiched layers causes Birefringence (light is refracted into two separate beams causing reading errors)	No birefringence as no sandwiched layers
Laser	Uses red laser with wavelength of 780 nanometres	Uses red laser with wavelength of 650 nanometres Increases storage capacity	Uses red laser with wavelength of 650 nanometres. Increases storage capacity	Uses Blue laser with wavelength of 405 nanometres. Increases storage capacity
Read/Write Cycle				Numerous, up to 100,000 times
Head	Single Head so Read or Write at a time	Single Head so Read or Write at a time	Double Head so Read and Write simultaneously	Single Head so Read or Write at a time

Calculating the Storage Requirement of a File

Memory Size Measurement

It should be pointed out here that there is some confusion in the naming of memory sizes.

The unit was established by the **International Electro-technical Commission (IEC)** in 1998, has been accepted for use by all major standards organizations, and is part of the International System of Quantities. The kibibyte was designed to replace the kilobyte in those computer science contexts in which the term kilobyte is used to mean 1024 bytes. The interpretation of the kilobyte to denote 1024 bytes, conflicting with the SI definition of the prefix kilo (1000), is still common, mostly in informal computer science contexts.

The IEC convention is now adopted by some organisations. Manufacturers of storage devices often use the denary system to measure storage size. For example:

0 or 1 = 1 bit

4 bits = 1 nibble

8 bits = 2 nibbles = 1 byte

SI Units	IEC Units
1 kilo byte = 1000 byte	1 kibi byte (1 KiB) = 1,024 bytes
1 mega byte = 1000,000 bytes (1000 * 1000)	1 mebi byte (1 MiB) = 1,048,576 bytes (1,024 * 1,024)
1 giga byte = 1,000,000,000 bytes (1,000,000 * 1000)	1 gibi byte (1 GiB) = 1,073,741,824 bytes (1,048,576 * 1,024)
1 tera byte = 1,000,000,000,000 bytes and so on. (1,000,000,000 * 1000)	1 tebi byte (1 TiB) = 1,099,511,627,776 bytes and so on (1,073,741,824 * 1,024)

Example Question 1: A company advertises its backup memory device as having 500 GB of storage. A customer wishes to know how many 8 MB files could be stored on the device. The company claimed that up to 62 500 files (assuming each file is 8 MB) could be stored. The customer calculated that 64 000 files could be stored.

Explain the difference between these two storage values. Show any calculations you use in your explanation.

.....

Marking Scheme

- company calculation is based on 1 GByte = 1000 Mbyte
 - customer calculation based on 1 GByte = 1024 Mbyte
 - giving the difference of 1500 files
- [3]

Example Question 2: Bytes, Kilobytes and Megabytes are units used for the amount of data stored in a computer.

(a) State which of these units is most appropriate for the following items of data.

A one page text document:

A ten minute movie clip:

A person's surname: [3]

(b) A computer has a hard disk of 2 Terabytes.

How much is this in Gigabytes?

You **must** show your working.

.....

.....

.....

..... [2]

Marking Scheme

- a) • A 1-page text document: **Kilobyte(s)**
- A 10-min movie clip: **Megabyte(s)**
- A person's surname: **Byte(s)**
- (b) • Multiply by 1024/1000
- 2048/2000 (GB)

Topical Past Papers

Q 1) Summer 2015 P11

5 Five storage devices are described in the table below.

In column 2, name the storage device being described.

In columns 3, 4, or 5, tick (✓) to show the appropriate category of storage.

1	2	3	4	5
Description of storage device	Name of storage device	Category of storage		
		Primary	Secondary	Off-line
optical media which use one spiral track; red lasers are used to read and write data on the media surface; makes use of dual-layering technology to increase the storage capacity				
non-volatile memory chip; contents of the chip cannot be altered; it is often used to store the start up routines in a computer (e.g. the BIOS)				
optical media which use concentric tracks to store the data; this allows read and write operations to be carried out at the same time				
non-volatile memory device which uses NAND flash memories (which consist of millions of transistors wired in series on single circuit boards)				
optical media which use blue laser technology to read and write data on the media surface; it uses a single 1.1 mm polycarbonate disc				

Q 3) Winter 2015 P12

5 A security system uses sensors, a camera and a microprocessor to capture images of each person entering a large shopping mall.

(b) Each image taken requires 1 MB of storage. If the camera captures an image every 5 seconds over a 24 hour period, how much storage is required?

Give your answer in **gigabytes** and show all your working.

.....

[2]

(c) The shopping mall has over 100 cameras. At the end of each day all these cameras send their images, captured over the last 24 hours, to a central computer.

Explain why the mall uses dedicated fibre optic cable rather than transmitting the data over the local broadband network.

.....

[2]

9 A remote-controlled model car contains RAM, ROM and a solid state drive. The car receives radio signals from its remote control. It can only receive radio signals of a certain frequency. The manufacturer sets this frequency and the owner cannot change it. The owner of the model car can input their own sequence of movements from an interface underneath the car.

(a) Describe the purpose of each of the three types of memory supplied with the car.

RAM:

.....

ROM:

.....

Solid state drive:

.....[3]

(b) The owner needs to be able to enter their own sequence of movements for the model car. Name a suitable input device.

Input device:

Give a reason for your choice of device.

.....

.....[2]

(c) Explain why the model car uses a solid state drive rather than another type of secondary storage.

.....

.....

.....[2]

Q 4) Winter 2015 P13

5 A security system records video footage. One minute of video requires 180 MB of storage. The recording system can store several hours of video footage.

(a) Name and describe a suitable storage device for this recording system.

.....

.....

.....[2]

(b) Calculate how much storage would be needed for 2 hours of video footage. Show your working and give the answer in Gigabytes (GB).

.....

.....

.....[2]

Q 5) Winter 2015 P11

1 (b) Describe **two** differences between Blu-ray discs and DVDs.

1:

2:

.....[2]

(c) Describe **two** differences between DVD-R and DVD-RAM.

1:

2:

.....[2]

7 (c) A company advertises its backup memory device as having 500 GB of storage. A customer wishes to know how many 8 MB files could be stored on the device. The company claimed that up to 62 500 files (assuming each file is 8 MB) could be stored. The customer calculated that 64 000 files could be stored.

Explain the difference between these two storage values. Show any calculations you use in your explanation.

.....

.....

.....

.....

..... [3]

9 (b) Nicolae needs to send 30 photos to a friend and he chooses to send all 30 together as a single email attachment. Each photo is 1.8 MB in size, but the maximum possible attachment size is only 20 MB. State how Nicolae can solve this problem.

.....

..... [1]

Q 6) Summer 2016 P11 & P13

11 (a) The table below shows four features of optical storage media.

Tick (✓) the appropriate boxes in the table to indicate which of the features apply to each example of optical storage media. [4]

Single track	Many concentric tracks	Blue laser used to read/write data	Red laser used to read/ write data
DVD-RW			
DVD-RAM			
CD-ROM			
Blu-ray disc			

(b) Solid state drives (SSD) are replacing hard disc drives (HDD) in some computers.

(i) Give **three** reasons why this is happening.

1

.....

2

.....

3

..... [3]

(ii) Explain why many web servers still use hard disc drive (HDD) technology.

.....

 [2]

10 There are **six** descriptions in the table below.

Complete the table below by writing the correct storage device or media in the box next to each description. [6]

Description	Storage device or media
Non-volatile memory that can only be read from and not written to.	
Optical storage media that allows very high storage capacity by using blue/violet laser technology.	
Volatile memory that stores data, programs and the parts of the operating system that are currently in use.	
Optical storage media that uses a single spiral track and uses dual layer technology, allowing high data storage capacity.	
Device that stores data by controlling the movement of electrons within a microchip; there are no moving parts.	
Optical storage media that uses concentric tracks allowing writing and reading to take place at the same time.	

Examiner Report Question 10

Many candidates were able to provide suitable storage device. Common errors were the confusion of CD and DVD, and also not being specific enough for sold state, stating USB, but not relating it to being a USB storage device. USB alone can refer to many things.

Q 8) Winter 2016 P12

8 Identify whether the **four** statements about file compression are correct by writing TRUE or FALSE in the following table. [4]

Statement	TRUE or FALSE
MIDI files store the actual music notes in a compressed format	
JPEG files are examples of lossless file compression	
MP3 files are, on average, 90% smaller than the music files stored on a CD	
MP4 files are examples of lossy file compression	

Q 9) Winter 2016 P11& 13

10 (b) The current status of the engine is sent to a computer in the aeroplane.

Each piece of data collected is 8 bytes in size. Data collection occurs every 30 seconds.

Calculate the number of kilobytes that would be needed to store the data collected during a 10-hour flight. Show your

working.....

..... kilobytes [3]

Q 10) March 2017 India

13 (a) Explain what is meant by primary, secondary and off-line storage. Give an example of each.

Primary storage

.....

Example

Secondary storage

.....

Example

Off-line storage

.....

Example [6]

(b) A set of photographs has been taken for a wedding. **All** the guests are to be sent digitally stored copies through the ordinary postal service. There are fifty photographs and each photograph is between 1.8 and 2.5 megabytes in size.

Work out the maximum storage space required for a set of photographs. State, with a reason, a suitable medium to use for the copies to be sent to the guests.

Maximum storage space

.....

Medium

Reason

..... [3]

Q 11) Summer 2017 P11

3 Steffi has a number of files of different sizes that contain her work. [4]

Tick to show whether each statement is **true** or **false**.

Statement	True	False
47KB is larger than 10MB.		
250bytes is smaller than 0.5MB.		
50GB is larger than 100MB.		
1TB is smaller than 4GB.		

8 Complete the paragraph by choosing **six** correct terms from the list.

- Optical
- On-line
- RAM
- HDD
- Primary
- SSD
- Secondary
- ROM
- Off-line

A computer has two different types of memory. memory is not directly accessed by the CPU, but it allows a user to store data that can easily be accessed by applications. Two examples of this type of memory are

and The second type of memory is memory. This memory is directly accessed by the CPU. It allows the processor to access data and instructions that are stored in this memory. Two examples of this memory are

and [6]

Q 12) Summer 2017 P12

2 Give **two** examples of primary, secondary and off-line storage.

Primary

Example 1

Example 2

Secondary

Example 1

Example 2

Off-line

Example 1

Example 2 [6]

Q 13) Winter 2017 P12

2 Storage devices and storage media can be categorised as primary, secondary or off-line.

Write **primary, secondary or off-line** next to each storage device or medium to indicate its most suitable category.

HDD

RAM

ROM

CD-ROM

SSD

DVD-RAM [6]

8 (a) A computer has 2048MB of RAM. How many GB of RAM does the computer have?

Show your working.

.....
.....
.....GB [2]

(b) Describe **one** item that is stored in RAM.

.....
..... [2]

(c) Explain **three** ways that RAM is different to ROM.

1

.....

.....

2

.....

.....

3
.....
..... [3]

Q 14) Winter 2017 P13

2 Data files are stored in different file formats.

Complete the table by providing a suitable file format for each file type. The first one has been done for you. [3]

File type	File format
Pictures	.JPEG
Text	
Sound	
Video	

9 (a) Optical storage media can be used to store data.

Describe how the data is read from a Compact Disc (CD).

.....
.....
.....
.....
..... [4]

(b) Kamil wants to store a 16-bit colour image file. The image size is 1000 pixels.

Calculate the size of the file. Give your answer in bytes. Show your working.

Working
.....
.....

Answer bytes [2]

(c) Describe the differences between primary and secondary storage.

.....
.....
.....
..... [4]

Q 15) March 2018 P12 (India)

6 Primary, secondary and off-line are types of storage.

Give an example of each type of storage. For each example state how it is used.

Primary storage Example

Use

Secondary storage Example

Use

Off-line storage Example

Use

..... [6]

9 A 32-second sound clip will be recorded. The sound will be sampled 16000 times a second. Each sample will be stored using 8 bits.

Calculate the file size in kilobytes. **You must show all of your working.**

File Size kB [3]

Q 16) Summer 2018 P11

8 (d) The supermarket uses secondary storage and off-line storage to store data about its stock.

Explain what is meant by secondary storage and off-line storage.

Secondary storage

.....
.....
.....
.....
.....
.....
.....

Off-line storage

.....
.....
.....
.....
.....
.....
..... [4]

Q 17) Summer 2018 P12

1 Different units of data can be used to represent the size of a file, as it changes in size.

Fill in the missing units of data, using the list given: [4]

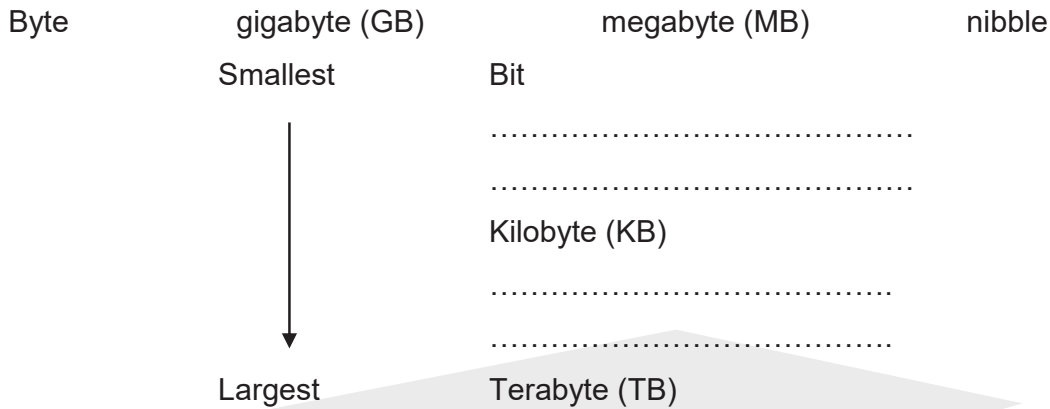

Q 18) Winter 2018 P12

2 A computer uses RAM and ROM to store data.

(a) The table contains three statements about RAM or ROM.

Tick (✓) to show whether each statement describes **RAM** or **ROM**. [3]

Statement	RAM(✓)	ROM(✓)
Stores the programs and data that are currently in use		
Used to boot up the computer when power is turned on		
Contents are retained when power is turned off		

(b) Circle the storage category that includes both RAM and ROM.

Primary Secondary Off-line [1]

(c) Explain what is meant by off-line storage.

.....

.....

.....

.....[2]

Q 19) Winter 2018 P13

9 Describe two differences between Read Only Memory (ROM) and Random Access Memory (RAM).

Difference 1

.....

.....

Difference 2
 [4]

13 State which types of storage device or media would be most suitable for these scenarios.

For each device or media, justify your choice.

(a) Creating a backup of 150GB of data. Device:
 Justification [2]

(b) Storing applications on a tablet Device.
 Justification [2]

(c) Storing a 1200MB high-definition promotional movie about a new car. The movie is to be given to people who are interested in buying a new car.
 Justification [2]

Q 20) March 2019 P12

1 (a) Elle has a file stored on her computer that is 20 MB in size. Jordan has a file that is 10GB in size. Tick (✓) to show which is the **larger** file. [1]

File size	Tick (✓)
20MB	
10GB	

(b) Bob has a file stored on his computer that is 3500kB in size. Gerty has a file that is 3MB in size. Tick (✓) to show which is the **larger** file. [1]

File size	Tick (✓)
3500kB	
3MB	

6 (c) Nadia uses several types of computer storage for her homework and other projects.

(i) Five examples of computer storage are given.

Tick (3) to show if the computer storage is **Primary**, **Secondary** or **Off-line**. [5]

Storage example	Primary (✓)	Secondary (✓)	Off-line (✓)
Solid state drive (SSD)			
Blu-ray disc			
USB flash memory			
Random access memory (RAM)			
Read only memory (ROM)			

6 (b) The law company wants to purchase a new file server.

The company can purchase a server with either solid state storage or magnetic storage. After discussion, it decides to purchase a file server with magnetic storage.

Explain why the company chose magnetic storage rather than solid state storage.

.....
.....
.....
.....
.....
.....
.....
.....
..... [4]

(c) The law company also uses optical storage. Give **three** different examples of optical storage.

1
2
3 [3]

Q 22) Summer 2019 P12

2 A finance company uses off-line storage to archive their accounts.

(a) Explain what is meant by off-line storage.

.....
.....
.....
..... [2]

(b) The computers in the finance company use both primary and secondary storage.

(i) Give **one** example of primary storage.

1 [1]

(ii) Give **two** examples of secondary storage.

1
2 [2]

4 (a) Marley wants to store a video he has created for his school project.

He considers using a DVD or a Blu-ray to store the video.

Explain **two** differences between a DVD and a Blu-ray.

1

.....

.....

.....

2

.....

.....

.....

(b) (i) Marley also needs to store ten 8-bit colour images in a file for his project. Each image is 500 pixels wide and 300 pixels high. Calculate the total file size in megabytes (MB) for all Marley's images. Show all your working. [2]

.....

.....

.....

.....

.....

.....

.....

.....

.....

File size MB [3]

7 (b) A microprocessor uses ROM. Explain what is meant by ROM.

.....

.....

.....

.....

.....

.....

.....

.....

.....

Q 24) Winter 2019 P12

1 Computer memory size is measured in multiples of bytes. **Four** statements about computer memory sizes are given in the table. **Tick (✓)** to show if the statement is **True** or **False**. [4]

Statement	True (✓)	False (✓)
25kB is larger than 100MB		
999MB is larger than 50GB		
3500kB is smaller than 2GB		
2350bytes is smaller than 2kB		

11 Robert has a mobile device that uses RAM, ROM and an SSD.

(a) State what the RAM, ROM and SSD are used for.

RAM

.....

ROM

.....

SSD

..... [3]

(b) Give **two** reasons why an SSD, rather than a HDD, is used in the mobile device.

Reason 1

.....

Reason 2

..... [2]

Q 25) March 20 P12

3 Priya studies music at school. She is buying a new computer to complete her school work at home.

(a) Priya has a choice between an internal Hard Disk Drive (HDD) and an internal Solid State Drive (SSD) to store data.

(i) Give **one** similarity between an HDD and an SSD.

.....

..... [1]

(ii) Explain **three** differences between an HDD and an SSD.

1

.....

.....

2

.....

.....

3

.....

.....

[3]

(b) Priya needs to transfer files between the school and her home computer.

Identify **one** off-line storage device she could use to transport the files.

.....

[1]

(c) Priya is using sound editing software to record and edit different music tracks.

(i) Identify **two** input devices she would use for this task.

Device 1

Device 2

[2]

(ii) Identify **two** output devices she would use for this task.

Device 1

Device 2

[2]

Q 26) Summer 20 P12) 9 (a) Six statements are given about storage devices. Tick (✓) to show if the statement applies to hard disk drive (**HDD**) storage or solid state drive (**SSD**) storage. Some statements can apply to both. [6]

Statement	HDD (✓)	SSD (✓)
It has a limited number of read/write cycles		
It uses magnetic properties to store data		
It has moving parts		
It is non-volatile storage		
It can be used as an external storage device to back up data		
It uses flash memory to store data		

(b) Optical storage is another type of storage.

Give **two** examples of optical storage.

Example 1

Example 2

[2]

Q 27) 15a Summer 20 P11) 1 (d) A smartphone needs both RAM and ROM.

State why a smartphone needs RAM and ROM.

RAM

.....

ROM

.....

[2]

Q 28) Winter 20 P12

3 Alessandro has some important data stored on his computer.

(b) Alessandro uses an SSD to store his data.

Describe what is meant by an SSD and how it operates to store data.

.....

.....

.....

.....

.....

.....

.....

.....

.....

.....

[4]

(c) Alessandro also uses off-line storage to store his data. Three examples of off-line storage are Blu-ray, CD and DVD. **Six** statements are given about off-line storage. Tick (✓) to show if each statement applies to **Blu-ray**, **CD**, or **DVD**. Some statements apply to more than one example of off-line storage.

[6]

Statement	Blu-ray (✓)	CD (✓)	DVD (✓)
A type of optical storage			
Has the largest storage capacity			
Can be dual layer			
Read using a red laser			
Has the smallest storage capacity			
Stores data in a spiral track			

Q 29) Winter 20 P13

1 Five hardware devices are given.

Tick (✓) to show if each device is an **Input**, **Output** or **Storage** device. [5]

Device	Input (✓)	Output (✓)	Storage (✓)
Solid state drive (SSD)			
Headphones			
2D cutter			
LCD projector			
Microphone			

9 Elle uses both CDs and DVDs to store her school projects.

(a) Give **three** similarities between a CD and a DVD.

- 1
- 2
- 3 [3]

(b) State **one** difference between a CD and a DVD.

- [1]

Q 30) March 21 P12

1 (c) The hockey club wants to increase the number of people that can watch each match to 2000. The 8-bit binary register may no longer be able to store the value.

Give the smallest number of bits that can be used to store the denary value 2000. [1]

Working space

.....

.....

.....

.....

4 A supermarket sells many products. Each product has a barcode.

(b) The supermarket stores data using a Solid State Drive (SSD).

(i) Explain how an SSD stores data.

-
-
-
-
- [3]

(ii) One advantage of an SSD rather than a Hard Disk Drive (HDD) is that it has no moving parts, so it is more durable. State **one** other advantage of the supermarket using SSD rather than HDD.

-
- [1]

18a Summer 21 P11

2 Julia inputs personal data into her computer. She stores three copies of the data using a hard disk drive (HDD), a solid state drive (SSD) and a USB flash memory drive.

(a) Identify three devices Julia can use to input personal data into her computer.

Device 1

Device 2

Device 3 [3]

(b) Six statements are shown about HDDs, SSDs and USB flash memory drives.

Tick (✓) to show which statements apply to each type of storage. Some statements can apply to more than one type of storage. [6]

Statement	HDD (✓)	SSD (✓)	USB flash memory drive (✓)
it has no moving parts			
it is non-volatile			
it can use NAND gates to store data			
it uses magnetic properties to store data			
it has the smallest physical size			
it has the slowest read/write speeds			

(c) Julia uses a USB connection to transfer data onto her USB flash memory drive.

(i) One benefit of using a USB connection is that it is a universal connection.

State two other benefits of using a USB connection.

Benefit 1

.....

Benefit 2

..... [2]

(ii) Identify the type of data transmission used in a USB connection.

..... [1]

Question	Answer	Marks
2(a)	Any three from: – Keyboard – Mouse – Microphone – Keypad – Touchscreen – Touchpad	3

Question	Answer	Marks																												
2(b)	One mark for each correct row. <table border="1" style="width: 100%; text-align: center;"> <thead> <tr> <th>Statement</th> <th>HDD (✓)</th> <th>SSD (✓)</th> <th>USB flash memory drive (✓)</th> </tr> </thead> <tbody> <tr> <td>it has no moving parts</td> <td></td> <td>✓</td> <td>✓</td> </tr> <tr> <td>it is non-volatile</td> <td>✓</td> <td>✓</td> <td>✓</td> </tr> <tr> <td>it can use NAND gates to store data</td> <td></td> <td>✓</td> <td>✓</td> </tr> <tr> <td>it uses magnetic properties to store data</td> <td>✓</td> <td></td> <td></td> </tr> <tr> <td>it has the smallest physical size</td> <td></td> <td></td> <td>✓</td> </tr> <tr> <td>it has the slowest read/write speeds</td> <td>✓</td> <td></td> <td></td> </tr> </tbody> </table>	Statement	HDD (✓)	SSD (✓)	USB flash memory drive (✓)	it has no moving parts		✓	✓	it is non-volatile	✓	✓	✓	it can use NAND gates to store data		✓	✓	it uses magnetic properties to store data	✓			it has the smallest physical size			✓	it has the slowest read/write speeds	✓			6
Statement	HDD (✓)	SSD (✓)	USB flash memory drive (✓)																											
it has no moving parts		✓	✓																											
it is non-volatile	✓	✓	✓																											
it can use NAND gates to store data		✓	✓																											
it uses magnetic properties to store data	✓																													
it has the smallest physical size			✓																											
it has the slowest read/write speeds	✓																													
2(c)(i)	Any two from: - It cannot be inserted incorrectly - Supports different transmission speeds - High speed transmission - Automatically detected (not connected) // automatically downloads drivers - Powers the device (for data transfer) - Backward compatible	2																												
2(c)(ii)	- Serial	1																												

18b Summer 21 P12

2 Data storage can be magnetic, solid state or optical.

(a) Six statements are given about data storage. Tick (✓) to show if the statement applies to magnetic, solid state or optical storage. Some statements may apply to more than one. [6]

Statement	Magnetic (✓)	Solid state (✓)	Optical (✓)
no moving parts are used to store data			
pits and lands are used to store data			
data is stored on platters			
flash memory is used to store data			
parts are rotated to store data			
data can be stored permanently			

(b) (i) Give one example of magnetic storage.

..... [1]

(ii) Give one example of optical storage.

..... [1]

(iii) Identify which type of storage would be the most suitable for use in a web server and justify your choice.

Type of storage

Justification

.....

.....

..... [3]

(c) Describe the operation of USB flash memory and how it stores data.

.....

.....

.....

.....

.....

..... [3]

2(a)	One mark per each correct row.	6																														
<table border="1" style="width: 100%; border-collapse: collapse;"> <thead> <tr> <th style="width: 50%; text-align: center;">Statement</th> <th style="width: 12.5%; text-align: center;">Magnetic (✓)</th> <th style="width: 12.5%; text-align: center;">Solid state (✓)</th> <th style="width: 12.5%; text-align: center;">Optical (✓)</th> </tr> </thead> <tbody> <tr> <td>no moving parts are used to store data</td> <td></td> <td style="text-align: center;">✓</td> <td></td> </tr> <tr> <td>pits and lands are used to store data</td> <td></td> <td></td> <td style="text-align: center;">✓</td> </tr> <tr> <td>data is stored on platters</td> <td style="text-align: center;">✓</td> <td></td> <td></td> </tr> <tr> <td>flash memory is used to store data</td> <td></td> <td style="text-align: center;">✓</td> <td></td> </tr> <tr> <td>parts are rotated to store data</td> <td style="text-align: center;">✓</td> <td></td> <td style="text-align: center;">✓</td> </tr> <tr> <td>data can be stored permanently</td> <td style="text-align: center;">✓</td> <td style="text-align: center;">✓</td> <td style="text-align: center;">✓</td> </tr> </tbody> </table>		Statement	Magnetic (✓)	Solid state (✓)	Optical (✓)	no moving parts are used to store data		✓		pits and lands are used to store data			✓	data is stored on platters	✓			flash memory is used to store data		✓		parts are rotated to store data	✓		✓	data can be stored permanently	✓	✓	✓			
Statement	Magnetic (✓)	Solid state (✓)	Optical (✓)																													
no moving parts are used to store data		✓																														
pits and lands are used to store data			✓																													
data is stored on platters	✓																															
flash memory is used to store data		✓																														
parts are rotated to store data	✓		✓																													
data can be stored permanently	✓	✓	✓																													
2(b)(i)	Any one from: – Hard disk drive // HDD – Magnetic tape	1																														

2(b)(ii)	<p>Any one from:</p> <ul style="list-style-type: none"> - CD - DVD - Blu-ray disk 	1
2(b)(iii)	<p>One for type of storage, two for matching justification from:</p> <ul style="list-style-type: none"> - Magnetic // HDD - (Web server) is likely to receive many requests a day - (Web server) will likely need to store a lot of data and magnetic is high capacity - Magnetic is cheaper to buy for storage per unit than solid state - Magnetic is capable of more of read/write requests over time // has more longevity // SSD has more limited number of read/write requests (before it is no longer usable) - No requirement for it to be portable, so moving parts does not matter - Solid-state // SSD - (Web server) is likely to receive many requests a day - (Web server) will likely need to store a lot of data and solid-state is high capacity - Solid-state is more energy efficient - Solid-state runs cooler so will not overheat - Solid state has faster read/write speeds to handle volume of traffic 	3
2(c)	<p>Any three from:</p> <ul style="list-style-type: none"> - Data is flashed onto (silicon) chips - Uses NAND/NOR technology // can use flip-flops - Uses transistors/control gates/floating gates ... - ... to control the flow of electrons - It is a type of EEPROM technology - When data is stored the transistor is converted from 1 to 0 / 0 to 1 - Writes (and reads) sequentially 	3

Marking Scheme

Q 1) Summer 2015 P11

5 1 mark per device, 1 mark per category

Description of storage device	Name of storage device	Category of storage		
		Primary	Secondary	Off-line
optical media which uses one spiral track; red lasers are used to read and write data on the media surface; makes use of dual-layering technology to increase the storage capacity	DVD			✓
non-volatile memory chip; contents of the chip cannot be altered; it is often used to store the start-up routines in a computer (e.g. the BIOS)	ROM	✓		
optical media which uses concentric tracks to store the data; this allows read and write operations to be carried out at the same time	DVD-RAM	✓		(✓)
non-volatile memory device that uses NAND flash memories (which consist of millions of transistors wired in series on single circuit boards)	Solid State Drive/memory (SSD)		✓	
	(SD/XD card) (USB storage device)			(✓)
optical media that uses blue laser technology to read and write data on the media surface; it uses a single 1.1 mm polycarbonate disc	Blue-ray			✓

Q 3) Winter 2015 P12

2

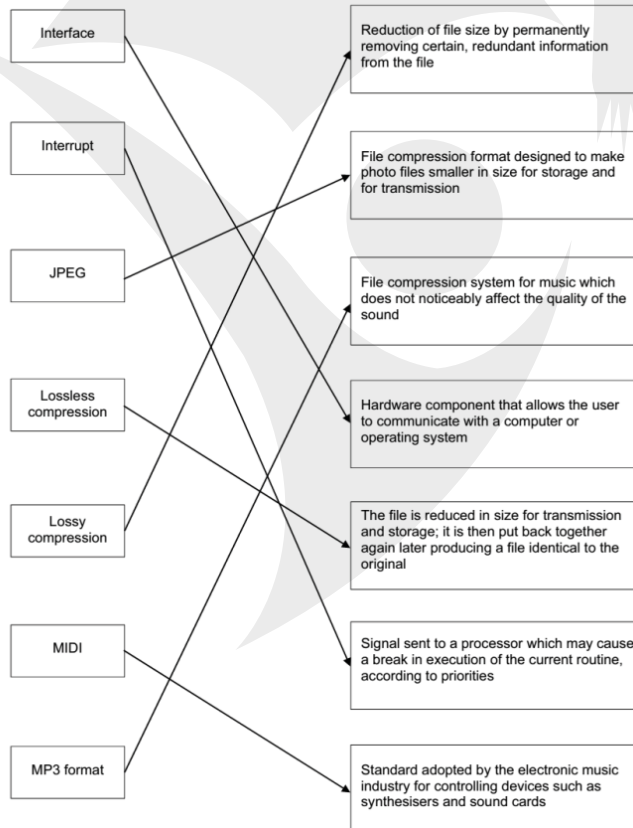

- 5 (a) Any **five** from:
- naming a suitable sensor, e.g infra-red, pressure, motion sensors, send signal/data to microprocessor
 - signal/data is converted to digital (using an ADC)
 - microprocessor instructs/send signals to camera to capture image/video
 - captured image/video data sent to microprocessor
- either**
- microprocessor compares the image/video with stored images/video...
 - ... if person detected = stored image ...
 - ... alert given to signal a person has been identified
- or**
- microprocessor compares the biometric data from an image/video with stored biometric data for images/video ...
 - ... if biometric data matched = stored data ...
 - ... alert given to signal a person has been identified
- Continual/repeated process [5]
- (b) 1 mark for correct calculation, 1 mark for correct answer
- number of photos = $12 \times 60 \times 24 = 17\,280$
 - memory requirement = $17\,280/1024 = 16.9$ (**16.875**)
 - ($17\,280/1000 = 17.28/17.3$ is acceptable) [2]
- (c) Any **two** from:
- (data transmission) is faster
 - more secure/safer (because it is a dedicated line)
 - (fibre optic transmission) is more reliable [2]
- 9 (a) **RAM**
- contains instructions/program/data currently in use
- ROM**
- any **one** from:
- contains the start-up/bootstrap program
 - contains/stores the setting for frequency (can't be changed)
- Solid state drive**
- stores the instructions/program/data (to operate the car)
- (b) 1 mark for device and 1 mark for corresponding reason
- Device:**
- touch screen
 - key pad (NOT keyboard)
- Reason:**
- easy to use interface
 - limited number of options
 - small space/space is limited
 - other devices such as mouse, keyboard, trackball, ... not suitable
- (c) Any **two** from:
- A solid state drive has no moving parts
 - A solid state drive has faster random access
 - A solid state drive has a quick start up/shut down time (reduced latency)
 - A solid state drive is very small
 - A solid state drive is very light
 - A solid state drive consumes very little power
 - A solid state drive does not generate a lot of heat (therefore safer in this application)

Q 4) Winter 2015 P13

- 5 (a) – Memory card/SSD/HDD/magnetic tape
– Suitable description of device given
- (b) 2 hours = 120 minutes
 $120 \times 180 = 21\,600$
 $21\,600/1024$ (or $21\,600/1000$)
 = **21.1 GB (or 21.6 GB)**
- (1 mark for correct answer and 1 mark for correct calculation)



9 (a) 8MB
100

- (b) (i) Any **two** from:
- removes sounds human ear can't hear very well
 - if two sounds played at same time, softer sound removed
 - uses perceptual music shaping

(ii) Lossy

- (iii) **One** from, for example:
- jpeg
 - MP4
 - zip
 - gif

Q 5) Winter 2015 P11

- (b) Any **two** from:
- Blu-ray discs use blue/violet lasers rather than red lasers as used by DVDs
 - storage capacity of Blu-ray discs is much higher than standard DVDs
 - Blu-ray discs use one polycarbonate layer; DVDs use two layers
 - Blu-ray discs have a built-in secure encryption system
- [2]

- (c) Any **two** from:
- DVD has one spiral track; DVD-RAM has several concentric tracks
 - DVD-RAM can be written to and read from at the same time; DVD-R only allows the read operation to occur
 - DVD-R only allows data to be read (can't write to it) whereas DVD-RAM allows reading and writing operation
- [2]

- 7 (a) Lossy
- when decompressed, some detail is lost and file is not exactly like the original (but difference is usually not noticeable)

Lossless

- when decompressed the original file is restored with no loss of data

- (b) 1 mark for type of file + 1 mark for description
e.g:

- JPG
- Used to store images/pictures
- MP3
- Used to store audio/sound files

- (c) Any **three** from:
- company calculation is based on 1 GByte = 1000 MByte
 - so $(500 \times 1000)/8 = 62\,500$ files
 - customer calculation based on 1 GByte = 1024 MByte
 - so $(500 \times 1024)/8 = 64\,000$ files
 - giving the difference of 1500 files

- 9 (a) Any **one** from:
- verification is being described
 - validation is when data follows a set of rules, e.g. length/range/type check

- (b) Any **one** from:
- send as JPEG files
 - carry out a file compression first

Q 6) Summer 2016 P11 & P13

11 (a) 1 mark for each correct row

	Single track	Many concentric tracks	Blue laser used to read/write data	Red laser used to read/write data	
DVD-RW	✓			✓	1 mark
DVD-RAM		✓		✓	1 mark
CD-ROM	✓			✓	1 mark
Blu-ray disc	✓		✓		1 mark

(b) (i) Any **three** from:

- don't need to "get up to speed" to work properly/no latency
- lower/less power consumption/more energy efficient
- run cooler
- run quieter
- data access is faster
- occupies less physical space/more compact
- lighter, so more suitable for a portable computer/laptop
- no moving parts so more reliable/durable in a portable computer/laptop

(ii) Any **two** from:

- HDD is cheaper for larger amounts of storage space
- HDD has greater longevity for read/write functions
- Expensive to change the technology // HDD are trusted technology
- No requirement for the increased speed of SSD

Q 7) Summer 2016 P12

Page 3	Mark Scheme	Syllabus	Paper
	Cambridge IGCSE – May/June 2016	0478	12

4 (a) Any **three** from:

- The file can be compressed
- The compression that is used is lossless (not lossy)
- use of a compression algorithm
- repeated words can be indexed
- repeated word sections (e.g. "OU") can be replaced by a numerical value
- reference to zip files
- save file as a pdf/convert to pdf

[3]

(b) Any **four** from:

- the checksum for the bytes is calculated
- this value is then transmitted with the block of data
- at the receiving end, the checksum is re-calculated from the block of data received
- the calculated value is then compared to the checksum transmitted
- if they are the same value, then the data was transmitted without any error
- if the values are different, then an error has been found
- if the values are different, then a request is sent for the data to be re-transmitted

[4]

10 1 mark for each correct storage device

ROM (not EPROM/PROM)
Blu-ray disc
RAM
DVD/ DVD-R(+R)/ DVD-RW(+RW)/ DVD-ROM (not CD or DVD-RAM)
SSD/example of a USB <u>storage device</u>
DVD-RAM

[6]

Q 8) Winter 2016 P12

8

Statement	TRUE or FALSE
MIDI stores the actual music notes in a compressed format	FALSE
JPEG files are examples of lossless file compression	FALSE
MP3 files are, on average, 90% smaller than the music files stored on a CD	TRUE
MP4 files are examples of lossy file compression	TRUE

[4]

Q 9) Winter 2016 P11& 13

(b) 2 marks for working + 1 mark for correct answer

Working

- $1200 \times 8 = 9600$ (bytes)
- $9600/1024$ or $9600/1000$

Answer

- 9.4 or 9.6 kilobytes

[3]

Q 10) March 2017 India

Question	Answer	Marks
7	High definition video – lossy (algorithm) – images may contain less detail without noticeable degradation in quality Text – lossless (algorithm) – so that the original and the decompressed text will be exactly the same	4

Question	Answer	Marks
13(a)	Primary storage – main memory inside a computer /directly accessed by CPU Example – ROM / RAM Secondary storage – non-volatile/persistent memory that is accessed by a device that is part of a computer system / not directly accessed by the CPU Example – HDD / SSD Off-line storage – non-volatile memory that can be removed from a computer system Example – DVD/ Blu-ray / CD / USB flash memory / removable or external HDD or SSD	6
13(b)	∞ 125 megabytes ∞ CD / <u>low capacity</u> flash memory ∞ good for mailing / inexpensive to buy	3

Q 11) Summer 2017 P11

Question	Answer	Marks															
3	1 mark per correct tick <table border="1"> <thead> <tr> <th>Statement</th> <th>true (✓)</th> <th>false (✓)</th> </tr> </thead> <tbody> <tr> <td>47KB is larger than 10MB.</td> <td></td> <td>✓</td> </tr> <tr> <td>250bytes is smaller than 0.5MB.</td> <td>✓</td> <td></td> </tr> <tr> <td>50GB is larger than 100MB.</td> <td>✓</td> <td></td> </tr> <tr> <td>1TB is smaller than 4GB.</td> <td></td> <td>✓</td> </tr> </tbody> </table>	Statement	true (✓)	false (✓)	47KB is larger than 10MB.		✓	250bytes is smaller than 0.5MB.	✓		50GB is larger than 100MB.	✓		1TB is smaller than 4GB.		✓	4
Statement	true (✓)	false (✓)															
47KB is larger than 10MB.		✓															
250bytes is smaller than 0.5MB.	✓																
50GB is larger than 100MB.	✓																
1TB is smaller than 4GB.		✓															
8	∞ Secondary ∞ HDD/SSD ∞ SSD/HDD ∞ Primary ∞ ROM/RAM ∞ RAM/ROM	6															

Q 12) Summer 2017 P12

Question	Answer	Marks
2	2 marks for each type of storage Primary storage ∞ RAM ∞ ROM Secondary storage ∞ hard disk drive (HDD) ∞ solid state drive (SSD) Off-line storage e.g. ∞ CD ∞ DVD ∞ Blu-ray ∞ Flash memory // USB storage ∞ <u>removable / external / portable</u> hard disk drive (HDD/SSD) ∞ SD card	6

Q 13) Winter 2017 P12

2	1 mark for each correct category: HDD – Secondary RAM – Primary ROM – Primary CD-ROM – Off-line SSD – Secondary DVD-RAM – Off-line	6
---	--	---

8(a)	1 mark for correct calculation method, 1 mark for correct answer: ∞ 2048/1024 (or 1024 × 2) ∞ 2 GB	2
8(b)	∞ Instructions/programs/data ∞ ... currently in use	2
8(c)	Any three from: ∞ RAM is volatile, ROM is non-volatile ∞ RAM is temporary, ROM is (semi) permanent ∞ RAM normally has a larger capacity than ROM ∞ RAM can be edited ROM cannot be edited // Data can be read from and written to RAM, ROM can only be read from.	3

Q 14) Winter 2017 P13

Question	Answer	Marks										
2	1 mark for each correct file format e.g. <table border="1" style="margin-left: auto; margin-right: auto;"> <thead> <tr> <th>File type</th> <th>File format</th> </tr> </thead> <tbody> <tr> <td>Pictures</td> <td>.JPEG</td> </tr> <tr> <td>Text</td> <td>.doc, .txt, .rtf, .docx, .odt .pdf</td> </tr> <tr> <td>Sound</td> <td>.mp3, .wav, .aif, .flac, .mid</td> </tr> <tr> <td>Video</td> <td>.mp4, .flv, .wmv</td> </tr> </tbody> </table>	File type	File format	Pictures	.JPEG	Text	.doc, .txt, .rtf, .docx, .odt .pdf	Sound	.mp3, .wav, .aif, .flac, .mid	Video	.mp4, .flv, .wmv	3
File type	File format											
Pictures	.JPEG											
Text	.doc, .txt, .rtf, .docx, .odt .pdf											
Sound	.mp3, .wav, .aif, .flac, .mid											
Video	.mp4, .flv, .wmv											

Question	Answer	Marks
9(a)	Any four from: – (Red) laser is used – (Laser beams) shines onto surface of the disk – It is rotated (at a constant speed) to be read – Surface is covered in a track (that spirals from the centre) – Data is represented on the surface using pits and lands – Pits and lands represent binary values – Pits reflect light back differently (to the area in between/land) – Optical device can determine the binary value from the light reflection	4
9(b)	1 mark for calculation, 1 mark for correct answer: – 1000 · 16 – 16000/8 – Answer is 2000 bytes	2
9(c)	Four from: (Max 2 for either primary or secondary) – Primary RAM and ROM – Secondary HDD and SSD – Primary is directly accessible by CPU – Secondary is not directly accessible by CPU – Primary is internal to computer – Secondary can be internal or external to the computer – Primary stores boot up instructions and can hold data whilst being processed – Secondary stores files/software – Primary has faster access speed – Secondary has a slower access speed – Primary has both volatile and non-volatile – Secondary is non-volatile	4

Q 15) March 2018 P12 (India)

Question	Answer	Marks
6	1 mark for suitable example and 1 mark for suitable associated use. Primary RAM stores OS <u>when running</u> / data <u>currently in use</u> / instructions <u>currently in use</u> ROM stores boot instructions / BIOS Cache stores frequently used instructions Secondary HDD / SSD... ...stores files / applications (by example) Offline CD/DVD/Blu-ray/Flash Memory/USB stick/Removable HDD/Removable SSD... ... stores files / applications (by example)	6

Question	Answer	Marks
9	Max 3 – 1 mark for correct answer and 2 marks for correct calculations. Any two from: 16000 ÷ 32 512000 / 1024 Or 16000 ÷ 8 128000 ÷ 32 4096000 / 8 512000 / 1024 Correct answer: 500 kB	3

Q 16) Summer 2018 P11

8(d)	Secondary Storage – any two from: <ul style="list-style-type: none"> – Not directly accessed by the CPU – Non-volatile storage – Secondary is internal to the computer/device – An example of secondary storage would be HDD/SSD Off-line storage – any two from: <ul style="list-style-type: none"> – Non-volatile storage – Off-line storage is storage that is removable from a computer/device // not internal // portable – An example of off-line storage would be CD/DVD/USB stick/SD card/magnetic tape/ external HDD/SSD 	4
------	---	---

Q 17) Summer 2018 P12

2210/12

Cambridge O Level – Mark Scheme
PUBLISHED

May/June 2018

Question	Answer	Marks
1	1 mark for each unit, in the given order: <ul style="list-style-type: none"> – nibble – byte – megabyte (MB) – gigabyte (GB) 	4

Q 18) Winter 2018 P12

Question	Answer	Marks												
2(a)	1 mark for each correct tick (✓) <table border="1" style="margin-left: 20px;"> <thead> <tr> <th>Statement</th> <th>RAM (✓)</th> <th>ROM (✓)</th> </tr> </thead> <tbody> <tr> <td>Stores the programs and data that are currently in use</td> <td style="text-align: center;">✓</td> <td></td> </tr> <tr> <td>Used to boot up the computer when power is turned on</td> <td></td> <td style="text-align: center;">✓</td> </tr> <tr> <td>Contents are retained when power is turned off</td> <td></td> <td style="text-align: center;">✓</td> </tr> </tbody> </table>	Statement	RAM (✓)	ROM (✓)	Stores the programs and data that are currently in use	✓		Used to boot up the computer when power is turned on		✓	Contents are retained when power is turned off		✓	3
Statement	RAM (✓)	ROM (✓)												
Stores the programs and data that are currently in use	✓													
Used to boot up the computer when power is turned on		✓												
Contents are retained when power is turned off		✓												
2(b)	Primary	1												
2(c)	Two from: <ul style="list-style-type: none"> ∞ Non-volatile storage ∞ Storage that can be disconnected/removed from the computer ∞ Any suitable example ∞ Must be (physically) connected to computer to obtain stored data ∞ Used to store files as a backup 	2												

Q 19) Winter 2018 P13

Question	Answer	Marks
3	Six from: <ul style="list-style-type: none"> ∞ A <u>pressure sensor</u> is used ∞ The sensor sends data/signals to the microprocessor ∞ Data is <u>converted to digital</u> format ∞ Microprocessor compares data value against set value ∞ If value \leq <u>2400 Kg/under weight limit</u> lift is permitted to operate ∞ If value $>$ <u>2400 Kg/over weight limit</u> signal is sent from the microprocessor to deliver warning message to passengers ∞ If value $>$ <u>2400 Kg</u> signal is sent from the microprocessor to lift mechanism to stop lift operating ∞ Weight continuously monitored 	6
9	Four from: <ul style="list-style-type: none"> ∞ ROM is permanent ... ∞ ... RAM is temporary ∞ ROM is non-volatile ∞ ... RAM is volatile ... ∞ ROM is read only ... ∞ ... RAM can have read/write operations ∞ ROM holds instructions for boot up ... ∞ ... RAM holds files / instructions in use 	4
12	Four from (Max three from each): MP3 <ul style="list-style-type: none"> ∞ Digital recording of sound ∞ Produced by recording software / microphone ∞ Used when distributing sound files ∞ Compressed file format MIDI <ul style="list-style-type: none"> ∞ Instructions of how to make sound ∞ Non-audio recording ∞ File created using digital musical instruments ∞ Produced by synthesizer ∞ Used when composing music ∞ Individual notes/instruments can be changed 	4

Question	Answer	Marks
13(a)	1 mark for storage, 1 mark for justification ∞ External/Removable HDD // External/Removable SSD // Large capacity USB Flash Drive ∞ Backups must be stored separately ∞ Will hold sufficient data ∞ Faster write abilities (SSD/USB drive only)	2

Question	Answer	Marks
13(b)	1 mark for storage, 1 mark for justification ∞ SSD // SD card // Flash memory ∞ Small physical size ∞ Lightweight ∞ Low heat production ∞ Low power consumption ∞ It's quiet ∞ Fast read/write times	2
13(c)	1 mark for storage, 1 mark for justification ∞ DVD // Blu-ray // USB Flash Drive // SD card ∞ Easy to distribute ∞ Small in size ∞ Cheap to buy ∞ Universal storage therefore compatible with many devices	2

Q 20) March 2019 P12

1(a)	<table border="1"> <thead> <tr> <th>File size</th> <th>Tick (✓)</th> </tr> </thead> <tbody> <tr> <td>20 MB</td> <td></td> </tr> <tr> <td>10 GB</td> <td>✓</td> </tr> </tbody> </table>	File size	Tick (✓)	20 MB		10 GB	✓	1																		
File size	Tick (✓)																									
20 MB																										
10 GB	✓																									
1(b)	<table border="1"> <thead> <tr> <th>File size</th> <th>Tick (✓)</th> </tr> </thead> <tbody> <tr> <td>3500 kB</td> <td>✓</td> </tr> <tr> <td>3 MB</td> <td></td> </tr> </tbody> </table>	File size	Tick (✓)	3500 kB	✓	3 MB		1																		
File size	Tick (✓)																									
3500 kB	✓																									
3 MB																										
4(c)	<ul style="list-style-type: none"> - Lossy would remove data - Lossless does not remove data // No data can be lost ... - Can be restored to original state ... - ... otherwise will not run / work correctly 	4																								
6(c)(i)	1 mark per each correct tick <table border="1"> <thead> <tr> <th>Storage example</th> <th>Primary</th> <th>Secondary</th> <th>Off-line</th> </tr> </thead> <tbody> <tr> <td>Solid state drive (SSD)</td> <td></td> <td>✓</td> <td></td> </tr> <tr> <td>Blu-ray disc</td> <td></td> <td></td> <td>✓</td> </tr> <tr> <td>USB flash memory</td> <td></td> <td></td> <td>✓</td> </tr> <tr> <td>Random access memory (RAM)</td> <td>✓</td> <td></td> <td></td> </tr> <tr> <td>Read only memory (ROM)</td> <td>✓</td> <td></td> <td></td> </tr> </tbody> </table>	Storage example	Primary	Secondary	Off-line	Solid state drive (SSD)		✓		Blu-ray disc			✓	USB flash memory			✓	Random access memory (RAM)	✓			Read only memory (ROM)	✓			5
Storage example	Primary	Secondary	Off-line																							
Solid state drive (SSD)		✓																								
Blu-ray disc			✓																							
USB flash memory			✓																							
Random access memory (RAM)	✓																									
Read only memory (ROM)	✓																									

6(c)(ii)	<p>Six from:</p> <ul style="list-style-type: none"> - Storage device has platters - Platters/disk divided into tracks - Storage platter / disk is spun - Has a read/write arm that moves across storage media - Read/writes data using electromagnets - Uses magnetic fields to control magnetic dots of data - Magnetic field determines binary value <p>NOTE: Marks can be awarded for an alternative description e.g. magnetic tape</p>	6
6(c)(iii)	<ul style="list-style-type: none"> - Magnetic is cheaper per unit of data - Magnetic has more longevity // Magnetic can perform more read/write cycles 	2

Q 21) Summer 2019 P11

5	<p>Five from:</p> <ul style="list-style-type: none"> • A (compression) algorithm is used • No data is removed in the process // original file can be restored • Repeated words (are identified) // Patterns in the data (are identified) • ... and are indexed/put into a table // by example • ... and are replaced with their index // by example • ... and their positions are stored (in the table) // by example • ... and the number of times the word/pattern appears is stored (in the table) // by example <p>NOTE: Other valid methods of lossless compression can be awarded marks</p>	5
6(b)	<p>Four from (max 3 marks for benefits only, without an explanation):</p> <ul style="list-style-type: none"> • More read/write cycles (over its lifetime) // greater longevity ... • ... likely to be a lot of read/write functions each day • Read/write speed is sufficient ... • ... even though it is slower than solid-state • Cheaper per unit of data stored ... • ... better value for the company to purchase • ... so the law company can afford to buy a server with greater storage capacity • No requirement for portability ... • ... as a server, it does not need to be moved • Trusted technology ... • ... it has been traditionally used for many years 	4
6(c)	<ul style="list-style-type: none"> • DVD • CD • Blu-ray 	3

Q 22) Summer 2019 P12

2(a)	<p>Two from:</p> <ul style="list-style-type: none"> - It is non-volatile - Can be easily disconnected from the computer - It is not directly accessed by the CPU - Suitable example e.g. CD, DVD, USB flash memory 	2
2(b)(i)	<p>One from:</p> <ul style="list-style-type: none"> - ROM - RAM 	1
2(b)(ii)	<p>Two from:</p> <ul style="list-style-type: none"> - HDD - SSD - Flash memory 	2

4(a)	<p>Two from e.g.:</p> <ul style="list-style-type: none"> - DVD uses red laser/light whereas <u>blu-ray</u> uses blue/violet laser/light - DVD has a smaller (storage) capacity // <u>Blu-ray</u> has a larger (storage) capacity - DVD has two layers (of polycarbonate) whereas <u>Blu-ray</u> disks have a single layer (of polycarbonate) - DVD has a slower transfer rate (of approximately 10 mbps) // <u>Blu-ray</u> has a faster transfer rate (of approximately 36 mbps) 	2
4(b)(i)	<p>2 marks for any two correct stages of working, 1 mark for correct answer.</p> <ul style="list-style-type: none"> - $500 * 300 * 10 // 150\ 000 * 10$ - $* 8$ then $\div 8$ (anywhere in the process) - $1\ 500\ 000 - 1024 \div 1024 // 1\ 500\ 000 \div 1\ 048\ 576$ - = 1.43 MB 	3
4(b)(ii)	<p>Four from:</p> <ul style="list-style-type: none"> - Rollers are used to move the paper through the printer - Nozzles spray/drop/jet ink onto the paper - Ink jets/print head/nozzles are moved across the paper (to distribute the ink) - Different colour inks are mixed to create required colours - Technology could be piezoelectric - Technology could be thermal bubble - Ink is heated - ... and expands/evaporates into a bubble - Bubble is pushed through the nozzle on to the paper - ... then the bubble collapses - Electrical current is applied to a crystal - ... which makes it vibrate - ... which forces a droplet of ink through the nozzle 	4
7(b)	<p>Three from:</p> <ul style="list-style-type: none"> - Read only memory - Non-volatile memory // Contents of memory are retained when power is turned off/permanent storage - Primary storage // directly accessed by the CPU - Holds firmware/boot-up instructions/start-up instructions/BIOS - Cannot be written to 	3

Q 23) Winter 2019 P13

1(a)(ii)	<p>Two from:</p> <ul style="list-style-type: none"> ∞ HDD ∞ SSD ∞ USB flash memory drive ∞ SD card ∞ Any optical 	2
7(a)(i)	<p>Three from:</p> <ul style="list-style-type: none"> ∞ RAM ∞ Primary memory ∞ Volatile memory ∞ Holds currently in use data/instructions ∞ Directly accessed by the CPU 	3

Q 24) Winter 2019 P12

2210/12

Cambridge O Level – Mark Scheme
PUBLISHED

October/November 2019

Question	Answer	Marks															
1	<p>One mark for each correct tick</p> <table border="1"> <thead> <tr> <th>Statement</th> <th>True (✓)</th> <th>False (✓)</th> </tr> </thead> <tbody> <tr> <td>25 kB is larger than 100 MB</td> <td></td> <td>✓</td> </tr> <tr> <td>999 MB is larger than 50 GB</td> <td></td> <td>✓</td> </tr> <tr> <td>3500 kB is smaller than 2 GB</td> <td>✓</td> <td></td> </tr> <tr> <td>2350 bytes is smaller than 2 kB</td> <td></td> <td>✓</td> </tr> </tbody> </table>	Statement	True (✓)	False (✓)	25 kB is larger than 100 MB		✓	999 MB is larger than 50 GB		✓	3500 kB is smaller than 2 GB	✓		2350 bytes is smaller than 2 kB		✓	4
Statement	True (✓)	False (✓)															
25 kB is larger than 100 MB		✓															
999 MB is larger than 50 GB		✓															
3500 kB is smaller than 2 GB	✓																
2350 bytes is smaller than 2 kB		✓															

Question	Answer	Marks
5(a)	Four from: <ul style="list-style-type: none"> ∞ A compression algorithm is used ∞ Discards any unnecessary sounds ... ∞ ... using perceptual musical shaping ∞ ... such as removing background noise / sounds humans can't hear // or other suitable example ∞ Reduces sample size / resolution // by example ∞ Reduces sample rate // by example ∞ Sound is clipped ∞ The data is permanently removed 	4
5(b)(i)	One from: <ul style="list-style-type: none"> ∞ The file size will be smaller than lossless ∞ Requires less storage space ∞ Requires less time to transmit 	1
5(b)(ii)	One from: <ul style="list-style-type: none"> ∞ The quality of the sound will be reduced ∞ The original file cannot be restored 	1

2210/12

Cambridge O Level – Mark Scheme
PUBLISHED

October/November 2019

Question	Answer	Marks
5(c)(i)	Four from: <ul style="list-style-type: none"> ∞ Musical Instrument Digital Interface file ∞ Stores a set of commands / instructions for how the sound should be played ∞ Does not store the actual sounds ∞ Data in the file has been recorded using digital instruments ∞ Specifies pitch of the note // specifies the note to be played ∞ Specifies when each note plays and stops playing // Specifies key on/off ∞ Specifies duration of the note ∞ Specifies volume of the note ∞ Specifies the tempo ∞ Specifies the type of instrument 	4
5(c)(ii)	Four from: <ul style="list-style-type: none"> ∞ It uses a single wire ... ∞ ... therefore, it is cheaper to manufacture / buy / install ∞ ... therefore, less likely to have interference // no crosstalk ∞ ... therefore, can be used over longer distances ∞ Data is sent a bit at a time ... ∞ ... therefore, less chance of data being skewed // data is received in order ∞ Transmission can be synchronised ... ∞ ... can reduce rate of errors 	4

2210/12

Cambridge O Level – Mark Scheme
PUBLISHED

October/November 2019

Question	Answer	Marks
11(a)	RAM <ul style="list-style-type: none"> ∞ To store the data / instructions / parts of OS that are currently in use ROM <ul style="list-style-type: none"> ∞ To store the firmware / bootup instructions / BIOS SSD <ul style="list-style-type: none"> ∞ To store files / software // by example 	3
11(b)	Two from: <ul style="list-style-type: none"> ∞ It is more durable // it has no moving parts ∞ It has a faster read / write / access speed ∞ It is more compact / light weight / smaller / portable ∞ It uses less energy // battery will last longer ∞ It is quieter ∞ Not affected by magnetic forces ∞ It runs at a cooler temperature ∞ Less latency // takes less time to warm up 	2



Q 25) March 20 P12

0478/12

Cambridge IGCSE – Mark Scheme
PUBLISHED

March 2020

Question	Answer	Mark
3(a)(i)	Any one from: <ul style="list-style-type: none"> • They are both non-volatile • They are both secondary storage // Both not directly accessed by the CPU • They both have a high capacity of storage • Both have read and write abilities 	1
3(a)(ii)	Any three from: <ul style="list-style-type: none"> • HDD has moving parts but SSD does not • HDD uses magnetic storage whereas SSD uses flash memory • HDD is slower to access data than SSD // HDD has greater latency than SSD • HDD will create noise/heat, whereas SSD runs quieter/cooler • HDD has higher power consumption than SSD • HDD have greater longevity/more read-write cycles whereas SSD has lower longevity/limited number of read-write cycles • HDD larger in physical size/heavier than SSD • HDD is normally cheaper for the same capacity of storage as SSD • HDD is available in a larger storage capacity than SSD 	3
3(b)	Any one from: <ul style="list-style-type: none"> • USB flash memory drive • External HDD/SSD • SD Card • CD / DVD / Blu-ray 	1
3(c)(i)	Any two from: <ul style="list-style-type: none"> • Keyboard • Mouse • Microphone • Touchscreen 	2
3(c)(ii)	Any two from: <ul style="list-style-type: none"> • Monitor / Screen • Speakers • Headphones • Printer 	2

0478/12

Cambridge IGCSE – Mark Scheme
PUBLISHED

March 2020

Question	Answer	Mark
3(d)	Any two from: <ul style="list-style-type: none"> • Uses a compression algorithm • Does not permanently remove any data • Repeated patterns of notes are identified ... • ... and are grouped, with an index <p>NOTE: Other possible methods of lossless compression of sound can be credited</p>	2
3(e)(i)	Any two from: <ul style="list-style-type: none"> • Stores the notes played and not the sound • Contains instructions/commands for digital instruments // Is recorded / played on a digital instrument e.g. synthesiser • Stores data about notes e.g. pitch byte (Note: Two examples can be awarded) • Can be a compressed format • Can edit individual notes 	2
3(e)(ii)	Any two from: <ul style="list-style-type: none"> • Contains actual sound • Contains samples of the sound wave • Contains metadata // by example • Uses lossy compression • Recorded using microphone // Is recorded/played on an MP3 recorder/player 	2

Q 26) Summer 20 P12

Question	Answer			Marks
9(a)	Statement	HDD (✓)	SSD (✓)	6
	It has a limited number of read/write cycles		✓	
	It uses magnetic properties to store data	✓		
	It has moving parts	✓		
	It is non-volatile storage	✓	✓	
	It can be used as an external storage device to back-up data	✓	✓	
	It uses flash memory to store data		✓	

2210/12

Cambridge O Level – Mark Scheme
PUBLISHED

May/June 2020

Question	Answer	Marks
9(b)	Any two from: - CD (drive) - DVD (drive) - Blu-ray (drive)	2

Q 27) 15a Summer 20 P11

1(d)	- It needs RAM to store the data and programs currently in use - It needs ROM to permanently store the boot up instructions	2
3(c)	- A compression algorithm is used - No data is removed in the compression process - An index/dictionary of pixels is created - The number of times a pixel is repeated in a row is stored	4

Q 28) Winter 20 P12

1(c)(ii)	<p>One from:</p> <ul style="list-style-type: none"> - Lossy (compression) <p>Any three from:</p> <ul style="list-style-type: none"> - A (compression) algorithm is used - Removes redundant/unnecessary data from the file - Removes sounds that cannot be heard by the human ear/background noise - Reduces sample rate - Reduces sample resolution - Data is permanently removed // original file cannot be re-instated - Perceptual music shaping is used <p>NOTE: If lossless given, marks can be awarded for a correct description of lossless as follow through.</p> <p>Any three from (lossless):</p> <ul style="list-style-type: none"> - A (compression) algorithm is used - Repeating patterns are identified - ... are replaced with a value - ... and indexed - No data is permanently removed // original file can be re-instated - Suitable example of a lossless algorithm 	4
1(c)(iii)	<p>Any two from:</p> <ul style="list-style-type: none"> - Quicker for her to upload - Quicker for users to download - Won't slow website down as much when loading - Takes up less storage space 	2



3(b)	<p>Max three from:</p> <ul style="list-style-type: none"> - Solid state drive - Non-volatile - Secondary storage - Flash memory - Has no mechanical/moving parts - Uses transistors - ... and cells that are laid out in a grid - Uses control gates and floating gates - Can be NAND/NOR (technology) - Use EEPROM technology <p>Max two from:</p> <ul style="list-style-type: none"> - Stores data by flashing it onto the chips - Data stored by controlling the flow of electrons through/using transistors/chips/gates - The electric current reaches the control gate and flows through to the floating gate to be stored - When data is stored the transistor is converted from 1 to 0 	4																												
3(c)	<p>One mark for each correct row:</p> <table border="1" data-bbox="256 719 871 1055"> <thead> <tr> <th>Statement</th> <th>Blu-ray (✓)</th> <th>CD (✓)</th> <th>DVD (✓)</th> </tr> </thead> <tbody> <tr> <td>A type of optical storage</td> <td>✓</td> <td>✓</td> <td>✓</td> </tr> <tr> <td>Has the largest storage capacity</td> <td>✓</td> <td></td> <td></td> </tr> <tr> <td>Can be dual layer</td> <td>✓</td> <td></td> <td>✓</td> </tr> <tr> <td>Read using a red laser</td> <td></td> <td>✓</td> <td>✓</td> </tr> <tr> <td>Has the smallest storage capacity</td> <td></td> <td>✓</td> <td></td> </tr> <tr> <td>Stores data in a spiral track</td> <td>✓</td> <td>✓</td> <td>✓</td> </tr> </tbody> </table>	Statement	Blu-ray (✓)	CD (✓)	DVD (✓)	A type of optical storage	✓	✓	✓	Has the largest storage capacity	✓			Can be dual layer	✓		✓	Read using a red laser		✓	✓	Has the smallest storage capacity		✓		Stores data in a spiral track	✓	✓	✓	6
Statement	Blu-ray (✓)	CD (✓)	DVD (✓)																											
A type of optical storage	✓	✓	✓																											
Has the largest storage capacity	✓																													
Can be dual layer	✓		✓																											
Read using a red laser		✓	✓																											
Has the smallest storage capacity		✓																												
Stores data in a spiral track	✓	✓	✓																											

Q 29) Winter 20 P13

1	<p>One mark for each correct row:</p> <table border="1" data-bbox="256 1196 796 1491"> <thead> <tr> <th>Device</th> <th>Input (✓)</th> <th>Output (✓)</th> <th>Storage (✓)</th> </tr> </thead> <tbody> <tr> <td>Solid state drive (SSD)</td> <td></td> <td></td> <td>✓</td> </tr> <tr> <td>Headphones</td> <td></td> <td>✓</td> <td></td> </tr> <tr> <td>2D cutter</td> <td></td> <td>✓</td> <td></td> </tr> <tr> <td>LCD projector</td> <td></td> <td>✓</td> <td></td> </tr> <tr> <td>Microphone</td> <td>✓</td> <td></td> <td></td> </tr> </tbody> </table>	Device	Input (✓)	Output (✓)	Storage (✓)	Solid state drive (SSD)			✓	Headphones		✓		2D cutter		✓		LCD projector		✓		Microphone	✓			5
Device	Input (✓)	Output (✓)	Storage (✓)																							
Solid state drive (SSD)			✓																							
Headphones		✓																								
2D cutter		✓																								
LCD projector		✓																								
Microphone	✓																									
9(a)	<p>Any three from:</p> <ul style="list-style-type: none"> - Both need a red laser to read/write data - Both are spun to be read - Both use spiral tracks for data - Both are optical storage - Both are off-line storage // both non-volatile - Both use pits and lands to store data 	3																								
9(b)	<p>Any one from:</p> <ul style="list-style-type: none"> - DVD can be dual layer, but CD can only be single - DVD has higher storage capacity - DVD has a shorter wavelength laser - DVD are spun faster - DVDs have a higher data transfer rate 	1																								

Q 30) March 21 P12

1(c)	- 11	1
2(a)	<p>Any three from:</p> <ul style="list-style-type: none"> - A compression algorithm is used - Data will be lost/deleted permanently // original file cannot be recreated - Reduce the range of colours used / colour depth / bits per pixel - Reduce the number of pixels / image resolution removes data that will not be noticed by the user // removes unnecessary data 	3
4(b)(i)	<p>Max three from:</p> <ul style="list-style-type: none"> - Flash storage - Uses transistors/controls gates/floating gates - Can be NAND/NOR technology // Can use flip-flops - Stores data by flashing it onto the chips/device - Controlling/using the flow of electrons through/using transistors/chips/gates - The electric current reaches the control gate and flows through to the floating gate to be stored - When data is stored the transistor is converted from 1 to 0 / 0 to 1 	3
4(b)(ii)	<p>Max one from:</p> <ul style="list-style-type: none"> - Faster read/write operation - Produces less heat // needs less cooling - Less susceptible to interference/magnets - Less power consumption 	1

Chapter 7

1.3.6 Operating systems



Learning Outcome	To Read	Have Read	To Revise	Have Revised	Prepared
1.3.6: Operating systems					
<ul style="list-style-type: none"> describe the purpose of an operating system (Candidates will be required to understand the purpose and function of an operating system and why it is needed. They will not be required to understand how operating systems work.) 					
<ul style="list-style-type: none"> show understanding of the need for interrupts 					

Software:

Data and programs of computer are known as software.

There are two main types of software: systems software and application software

System Software

System software is a software that provides platform to other software.

Systems software includes the programs that are dedicated to managing the computer itself, such as the operating system and utility software.

Operating System

An operating system (OS) is a type of system software that manages computer's hardware and software resources.

It provides common services for computer programs. An OS acts a link between the software and the hardware. It controls and keeps a record of the execution of all other programs that are present in the computer, including application programs and other system software.

Most operating systems comprise a large set of programs, only some of which are stored in the computer's memory all the time. Many of the routines available in the OS are stored on the hard drive so that they can be accessed when required. This saves space in the computer's main memory.

When you are using applications software, you are not communicating directly with the computer hardware. Your applications software communicates with OS program modules that communicate with the computer hardware on its behalf. Without an operating system, a computer is useless no matter how many programs you have.

Why an operating system is need?

An **operating system** is the most **important** software that runs on a **computer**. It manages the **computer's** memory and processes, as well as all of its software and hardware. It also allows you to communicate with the **computer** without knowing how to speak the **computer's** language. The hardware is unusable without an OS. Operating system hides complexity of hardware from user. It acts as an interface/ controls communications between user and hardware, hardware and software. It provides software platform / environment on which other programs can be run.

Do all computer need an operating system?

Not all computers have operating systems. The computer that controls the microwave oven in your kitchen, for example, doesn't need an operating system. It has one set of tasks to perform, very straightforward input to expect (a numbered keypad and a few pre-set buttons) and simple, never-changing hardware to control. For a computer like this, an operating system would be unnecessary baggage, driving up the development and manufacturing costs significantly and adding complexity where none is required. Instead, the computer in a microwave oven simply runs a single hard-wired program all the time.

The management tasks performed by the operating system are

1. Memory Management: The OS keeps track of every memory location and is responsible for making memory available for different processes, such as allocating free space in memory to programs. The OS also deals with virtual memory and swapping pages in and out of RAM. The OS keeps track of the primary memory and allocates the memory when a process requests it.

- Memory protection to ensure that two programs do not try to use the same space
- Use of virtual memory
- Deciding which processes need to be in main memory at any one time
- Location of processes within the memory
- By example, e.g. when process terminates, memory is made available

2. File Management: Allocates and de-allocates the resources and decides who gets the resources.

- Maintains directory structures
- Provides file naming conventions
- Controls access

3. Security: Prevents unauthorized access to programs and data by means of passwords.

- Makes provision for recovery when data is lost
- Provides usernames and passwords / encryption / user accounts
- Prevents unauthorised access
- Ensures privacy of data

4. Hardware Management

Programmers write software and users run this software. The software uses the hardware. The operating system has to ensure that the hardware does what the software wants it to do. Program development tools associated with a programming language allow a programmer to write a program without needing to know the details of how the hardware, particularly the processor, actually works. The operating system then has to provide the mechanism for the execution of the developed program.

5. Process /resource management

A program, during execution is referred as a process. Many process are running in computer at a time and each process needs access to computer resources.

The OS must manage the physical resources of the computer. Some resources are limited and must be managed to maximise the use of the computer system:

- A simple system has only one processor.
- Secondary storage is of a fixed size.
- Some input/output devices (e.g. printers) are shared.

Following process management tasks are done by operating system:

- Scheduling of processes / multi-tasking / multi-programming etc.
- Resolution of conflicts when two or more processes require the same resource

6. Provision of a software platform/ environment

- The OS provides a platform on which the applications software can run.

7. Interrupt handling

Interrupts are signals sent by a hardware or a software or a user to seek attention of operating system. Interrupts are handled by operating system like:

- Identifies priorities of interrupts
- Save current memory / process values /saves data on power outage
- Loads appropriate Interrupt Service Routine (ISR)

8. User- system interface

The OS provides a means of communication (the user interface) between the human user, or the outside world, and the computer. A user interface is needed to allow the user to get the software and hardware to do something useful. An operating system should provide at least the following for user input and output:

- a command-line interface
- a graphical user interface (GUI).

9. Error-detecting Aids: Production of dumps, traces, error messages, and other debugging and error-detecting methods.

10. Scheduling: The OS schedules process through its scheduling algorithms.

11. Device management

Every computer system has a variety of components that are categorised as 'devices'. Examples include the monitor screen, the keyboard, the printer and the webcam. The management of these requires:

- installation of the appropriate device driver software
- control of usage by processes.

Peripheral device control

Methods of communication between the OS and peripheral devices include the use of:

- **Buffers:** Temporary memory area in memory used to compensate the difference in speed of two devices.
- **Spooling:** Acronym for *simultaneous peripheral operations on-line*, spooling refers to putting jobs in a buffer, a special area in memory or on a disk where a device can access them when it is ready. Spooling is useful because devices access data at different rates.
- **Interrupts:** A signal sent from a peripheral device (hardware) or program event (software) or user to the operating system to indicate that the sender needs attention.
- **Polling:** The process carried out by an operating system of periodically interrogating each peripheral device in turn to discover whether it needs the attention of operating system.
- **Handshaking:** The process by which two devices negotiate the protocol, (rules) they will use to communicate for the rest of the session, or signal their readiness to send or receive data.

Interrupt

An interrupt is a signal/message from some device or software or user to indicate that some event has occurred and the device is seeking the attention of the processor.

Steps of dealing with interrupt

- Identify the source of the interrupt
- Disable all interrupts of a lower priority
- Save the contents of the registers onto Interrupt Handle
- Load and run the appropriate ISR code to deal with the interrupt
- Restore the registers from the interrupt handler
- Enable all interrupts
- Continue execution of the interrupted process

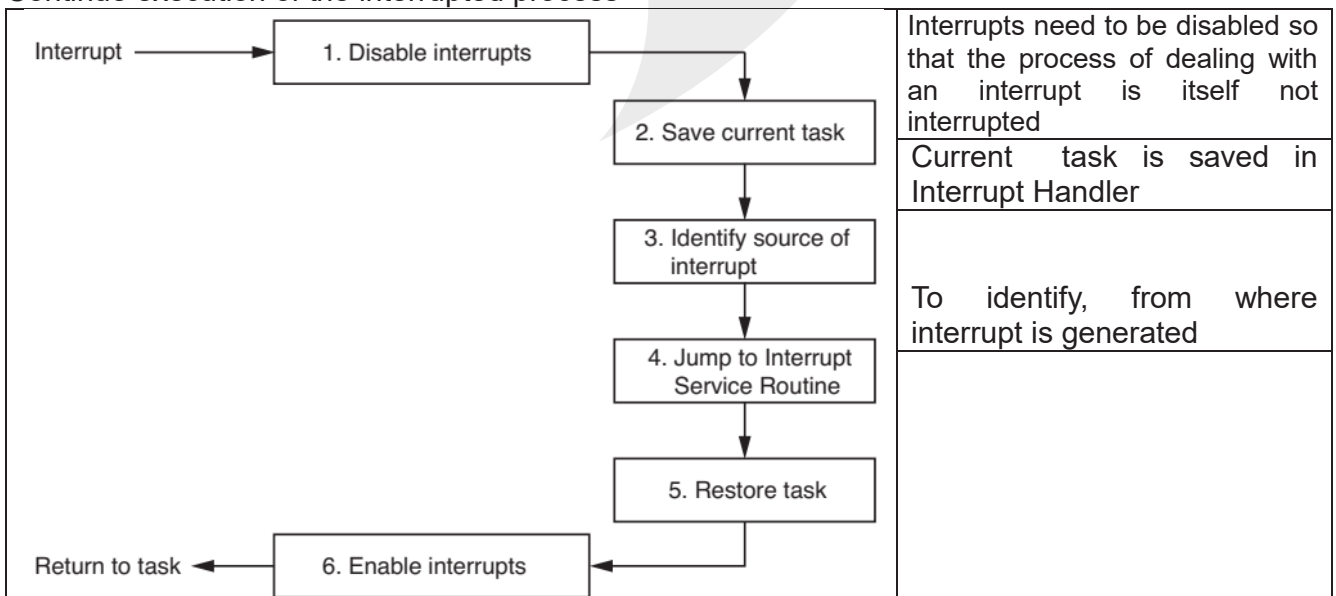

Role of Buffer and Interrupt in multi-tasking:

An interrupt is a signal/message from some device or software or user to indicate that some event has occurred and the device is seeking the attention of the processor.

For example:

- A printer sends interrupt when printer is out of ink.
- An anti-virus software has detected a virus
- A user wants to cancel a command and has pressed Ctrl, Alt, Break simultaneously

Buffer is temporary memory area used to compensate difference in speed of two devices.

Hardware devices operate at much slower speeds than the processor. If it wasn't for buffers, processors would spend the majority of their time idle, waiting for the hardware device to complete its operation. Interrupt and buffer play an important role in multi-tasking.

For example, in the process of printing, processor/operating system transfers the data from memory to printer buffer, when buffer is full, the processor/operating system can carry on with other tasks. The buffered in emptied to printer. When printer buffer is empty, printer sends an interrupt to the processor requesting more data to be sent. If there is more data is to be printed, processor refills the printer buffer and carry on with other tasks.

Buffers are also used, when streaming a video from the internet. This ensures that the video playback doesn't keep on stopping to wait for data from the internet.

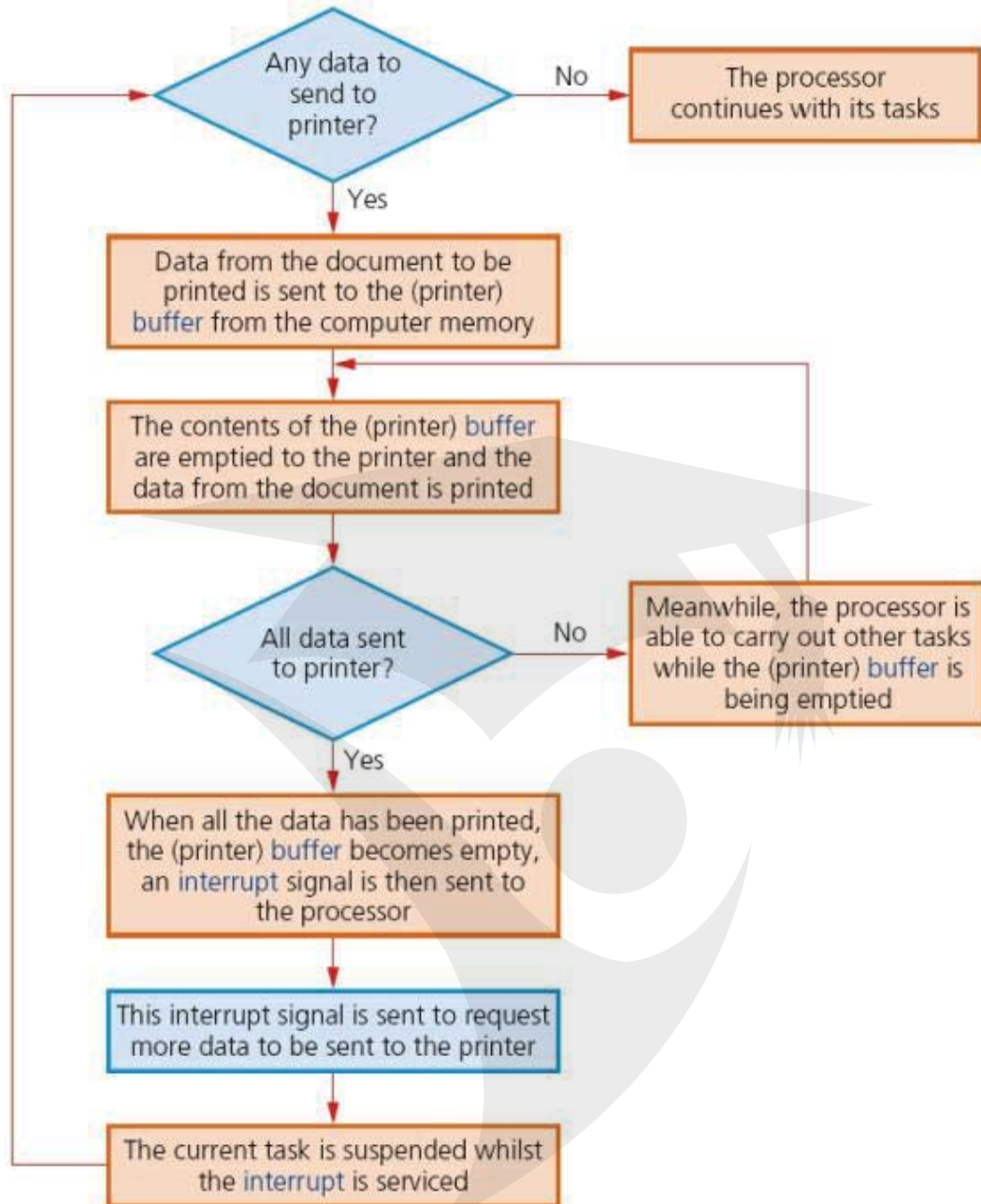

Topical Questions from Past Papers

Q1) 9691_13w_qp11

(a) What is meant by an interrupt?

.....
.....[1]

(b) A user starts the printing of a document, and then carries on editing a second document while printing continues.

Explain how interrupts make this possible.

.....
.....
.....
..... [4]

(c) Once a week the user runs a virus checker.

What action will be taken if the virus checker detects a virus in a file?

.....
..... [2]

(d) The computer is running a single-user operating system.

Describe what this means.

.....
..... [2]

Q2) 9691_13s_qp11

(a) Describe the terms buffer and interrupt.

Buffer:
..... [2]

interrupt:
..... [2]

(b) (i) Explain the role of the buffer and interrupts when a large document of over 200 pages is sent to a laser printer.

.....
..... [2]

(ii) The use of two buffers would speed up the printing process. Explain why.

.....
..... [2]

1 (a) **buffer** – any **one** from:
temporary storage area used to hold data before being transferred
allows for difference in working speeds (of processors and peripheral devices)

interrupt – any **one** from:
signal sent to the processor/CPU (which causes break in the execution of current routine) [2]

(b) (i) Any **three** points from:
data is transferred from (primary) memory to printer buffer
when the buffer is full, the processor can carry on with other tasks
printer buffer is emptied to printer
when printer buffer is empty, printer sends an interrupt to the processor requesting more data to be sent according to priorities [3]

(ii) Any **two** points from:
first (block) of data sent to the *first* buffer
whilst this data is being printed by the printer
next block of data is sent to the *second* buffer
when the *first* buffer is empty
data from the *second* buffer is then printed
meanwhile more data is then sent to the *first* buffer
this continues until all data has been processed by the printer [2]

Topical Past Papers

Q 1)8 State **three** features of a typical operating system.
1:
.....
2:
.....
3:
.....[3]

Q 2) Summer 2016 P11 & P13

4 (a) Nikita wishes to print out some documents and connects her printer to the computer using one of the USB ports.

(iii) The printer runs out of paper while it is printing the documents. A signal is sent to the processor to request that the problem is dealt with.

Name this type of signal.
.....[1]

Q 3) March 2017 India

6 The diagram shows **five** operating system functions and **five** descriptions.
Draw a line between each operating system function and its description. [4]

Function	Description
Interrupt	Many processes appear to run simultaneously
Utility	Data are temporarily held in a buffer waiting for an output device to access it
Memory management	A signal that causes the operating system to take a specified action
Spooling	A program that performs a specific task required for the operation of a computer system
Multitasking	A process of assigning blocks of memory to programs running in a computer

Examiner Report

Nearly all candidates identified the correct description for most of the operating system functions. Common errors included mixing up, 'Interrupt', 'Memory management' and/or 'Spooling'

Q 4) Winter 2017 P12

6 Selma writes the following **four** answers in her Computer Science examination.

State which computer terms she is describing.

"It is a signal. When the signal is received it tells the operating system that an event has occurred."

Selma is describing

"It takes source code written in a high level language and translates it into machine code. It translates the whole of the source code at once."

Selma is describing

"The part of the central processing unit (CPU) that carries out calculations."

Selma is describing

"When data is transmitted, if an error is detected in the data received a signal is sent to ask for the data to be retransmitted. This continues until the data received is correct."

Selma is describing[4]

Marking Scheme

Q 1) Winter 2015 P11

4

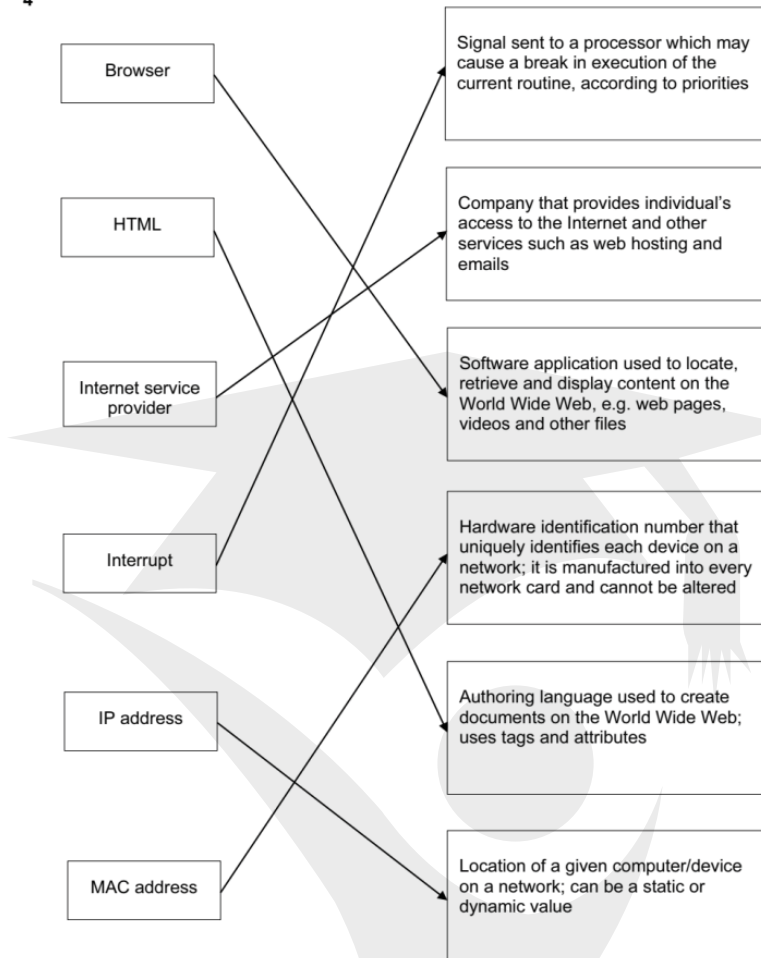

- 8 Any **three** from:
- provides a user interface
 - input/output control/handling
 - security
 - (handling) interrupts
 - spooling
 - memory management
 - processor management
 - utilities (e.g. copy, save, delete, rename, etc.)
 - maintain user accounts
 - load/run software
 - error reporting/handling
 - multiprogramming
 - batch processing/JCL
 - multitasking

Q 2) Summer 2016 P11 & P13

(iii) interrupt

[1]

Q 3) March 2017 India

Question	Answer	Marks				
6	<p>1 mark for each correctly drawn line from a function to its description to a maximum of 4</p> <table border="0" style="width: 100%;"> <tr> <td style="text-align: center; width: 50%;">Function</td> <td style="text-align: center; width: 50%;">Description</td> </tr> <tr> <td style="text-align: center;"> <div style="border: 1px solid black; padding: 5px; margin-bottom: 5px;">Interrupt</div> <div style="border: 1px solid black; padding: 5px; margin-bottom: 5px;">Utility</div> <div style="border: 1px solid black; padding: 5px; margin-bottom: 5px;">Memory management</div> <div style="border: 1px solid black; padding: 5px; margin-bottom: 5px;">Spooling</div> <div style="border: 1px solid black; padding: 5px; margin-bottom: 5px;">Multitasking</div> </td> <td style="text-align: center;"> <div style="border: 1px solid black; padding: 5px; margin-bottom: 5px;">Many processes appear to run simultaneously</div> <div style="border: 1px solid black; padding: 5px; margin-bottom: 5px;">Data are temporarily held in a buffer waiting for an output device to access it</div> <div style="border: 1px solid black; padding: 5px; margin-bottom: 5px;">A signal that causes the operating system to take a specified action</div> <div style="border: 1px solid black; padding: 5px; margin-bottom: 5px;">A program that performs a specific task required for the operation of a computer system</div> <div style="border: 1px solid black; padding: 5px; margin-bottom: 5px;">A process of assigning blocks of memory to programs running in a computer</div> </td> </tr> </table>	Function	Description	<div style="border: 1px solid black; padding: 5px; margin-bottom: 5px;">Interrupt</div> <div style="border: 1px solid black; padding: 5px; margin-bottom: 5px;">Utility</div> <div style="border: 1px solid black; padding: 5px; margin-bottom: 5px;">Memory management</div> <div style="border: 1px solid black; padding: 5px; margin-bottom: 5px;">Spooling</div> <div style="border: 1px solid black; padding: 5px; margin-bottom: 5px;">Multitasking</div>	<div style="border: 1px solid black; padding: 5px; margin-bottom: 5px;">Many processes appear to run simultaneously</div> <div style="border: 1px solid black; padding: 5px; margin-bottom: 5px;">Data are temporarily held in a buffer waiting for an output device to access it</div> <div style="border: 1px solid black; padding: 5px; margin-bottom: 5px;">A signal that causes the operating system to take a specified action</div> <div style="border: 1px solid black; padding: 5px; margin-bottom: 5px;">A program that performs a specific task required for the operation of a computer system</div> <div style="border: 1px solid black; padding: 5px; margin-bottom: 5px;">A process of assigning blocks of memory to programs running in a computer</div>	4
Function	Description					
<div style="border: 1px solid black; padding: 5px; margin-bottom: 5px;">Interrupt</div> <div style="border: 1px solid black; padding: 5px; margin-bottom: 5px;">Utility</div> <div style="border: 1px solid black; padding: 5px; margin-bottom: 5px;">Memory management</div> <div style="border: 1px solid black; padding: 5px; margin-bottom: 5px;">Spooling</div> <div style="border: 1px solid black; padding: 5px; margin-bottom: 5px;">Multitasking</div>	<div style="border: 1px solid black; padding: 5px; margin-bottom: 5px;">Many processes appear to run simultaneously</div> <div style="border: 1px solid black; padding: 5px; margin-bottom: 5px;">Data are temporarily held in a buffer waiting for an output device to access it</div> <div style="border: 1px solid black; padding: 5px; margin-bottom: 5px;">A signal that causes the operating system to take a specified action</div> <div style="border: 1px solid black; padding: 5px; margin-bottom: 5px;">A program that performs a specific task required for the operation of a computer system</div> <div style="border: 1px solid black; padding: 5px; margin-bottom: 5px;">A process of assigning blocks of memory to programs running in a computer</div>					

Q 4) Winter 2017 P12

6	<p>1 mark for each correct term, in this order:</p> <ul style="list-style-type: none"> ∞ Interrupt ∞ Compiler ∞ ALU/Arithmetic and Logic Unit ∞ ARQ/Automatic repeat request 	4
---	--	---

Q 5) March 2018 P12 (India)

Question	Answer	Marks
13	<p>Any four from</p> <ul style="list-style-type: none"> ∞ (Provides an) interface ∞ Loads / opens / installs / closes software ∞ Manages the hardware // manages peripherals // spooling ∞ Manages the transfer of programs into and out of memory ∞ Divides processing time // processor management ∞ Manages file handling ∞ Manages error handling / interrupts ∞ Manages security software ∞ Manages utility software ∞ Manages user accounts ∞ Multitasking // Multiprocessing // Multiprogramming // Time slicing ∞ Batch processing // real time processing 	4

Q 6) Winter 2018 P12

Question	Answer	Marks
8	<p>Four from:</p> <ul style="list-style-type: none"> ∞ Used to attend to certain tasks/issues ∞ Used to make sure that vital tasks are dealt with immediately ∞ The interrupt/signal tells the CPU/processor (that its attention is required) ∞ A signal that can be sent from a device (attached to the computer) ∞ A signal that can be sent from software (installed on the computer) ∞ The interrupt will cause the OS/current process to pause ∞ The OS/CPU/ISR will service/handle the interrupt ∞ They have different levels of priority ∞ After the interrupt is serviced, the (previous) process is continued ∞ It enables multi-tasking to be carried out on a computer ∞ A valid example of an interrupt e.g. 'out of paper' message for a printer 	4

Q 7) Winter 2019 P13

2210/13

Cambridge O Level – Mark Scheme
PUBLISHED

October/November 2019

Question	Answer	Marks																		
7(b)	<p>One mark for each correct row</p> <table border="1" style="width: 100%; border-collapse: collapse;"> <thead> <tr> <th style="width: 70%;">Statement</th> <th style="width: 15%;">True (✓)</th> <th style="width: 15%;">False (✓)</th> </tr> </thead> <tbody> <tr> <td>Interrupts can be hardware based or software based</td> <td style="text-align: center;">✓</td> <td></td> </tr> <tr> <td>Interrupts are handled by the operating system</td> <td style="text-align: center;">✓</td> <td></td> </tr> <tr> <td>Interrupts allow a computer to multitask</td> <td style="text-align: center;">✓</td> <td></td> </tr> <tr> <td>Interrupts work out which program to give priority to</td> <td></td> <td style="text-align: center;">✓</td> </tr> <tr> <td>Interrupts are vital to a computer and it cannot function without them</td> <td style="text-align: center;">✓</td> <td></td> </tr> </tbody> </table>	Statement	True (✓)	False (✓)	Interrupts can be hardware based or software based	✓		Interrupts are handled by the operating system	✓		Interrupts allow a computer to multitask	✓		Interrupts work out which program to give priority to		✓	Interrupts are vital to a computer and it cannot function without them	✓		5
Statement	True (✓)	False (✓)																		
Interrupts can be hardware based or software based	✓																			
Interrupts are handled by the operating system	✓																			
Interrupts allow a computer to multitask	✓																			
Interrupts work out which program to give priority to		✓																		
Interrupts are vital to a computer and it cannot function without them	✓																			

“A set of rules that provide a way of telling computer what operation to perform is called a Programming Language.”

A **COMPUTER PROGRAM** is a list of instructions that enable a computer to perform a specific task. Computer needs instructions to perform a task.

There are some rules and regulations to write programs and these rules and regulations are programming languages.

Different types of programming languages are given below:

1. Low Level Language (Machine Language and Assembly Language)
2. High level Languages (Python, Java, VB.net, C++ etc.)

1) Machine Language: (Low Level Language)

Machine languages are the most basic languages. They consist of a series of current signals ‘On’ and ‘Off’. On is represented by ‘1’ and off is represented by ‘0’. It is 1st generation of language.

Machine language is also called Binary Digits. It is computer’s language in which different parts of computer communicate with each other. 0s and 1s are called bit (binary digit).

Machine language is easy for computer and difficult for programmer. Every computer has its own unique machine language. It means machine for Apple Macintosh is different from IBM compatible.

Machine Language Code
000100101111010101001111010101 010001001010000111110101010111 0101000111110101011101100100110 00010101001010101011111011111

Machine Language Code
12EF A243 4EC2 33C2 3D23 4E23 4FFA CA12 ACEF F234 DE12 F98A

2) Assembly Language: (Low Level Language)

Assembly language consists of English like symbolic codes known as mnemonics. It is a second generation of language.

They represent common strings of machine codes. A language translator, Assembler, is used to convert source code of Assembly language program into object code of machine language. Though Assembly languages are easier than machine language but they are highly detailed and cryptic. So programmers seldom write programs in Assembly language.

Advantages of Assembly languages:

- to make use of special hardware
- to make use of special machine-dependent instructions
- to write code that doesn’t take up much space in primary memory
- to write code that performs a task very quickly.

In order to understand this program the programmer needs to know that

- **LDD** means load the value of the variable from memory into the accumulator
- **ADD** means add the value of another variable to the value stored in the accumulator
- **STO** means store the value for accumulator into memory.

Assembly Code (Source code)
LDD 101 ADD 102 STO 103

3) High Level Languages

High-level languages consist of familiar English words as result programmers can read, write and understand programs easily.

A language translator (compiler or interpreter) translates source code of High Level Language into object code. That's why the program of High Level Language can be executed on any machine.

High Level Code (Source code)
<pre>For Count=1 to 10 Print "Allah" Next Count</pre>

High-level languages are designed with programmers in mind; programming statements are easier to understand than those written in a low-level language. This means that programs written in a high-level language are easier to:

- read and understand as the language used is closer to human language
- write in a shorter time
- debug at the development stage
- maintain once in use.

Examples: Python, COBOL, Pascal, FORTRAN, GWBASIC, C++, JAVA, VB.Net.

Source Code:

"A program written in any language except the machine language is called Source Code."

Programmers can write programs in Machine Language, Assembly Language and High Level Languages like COBOL, PASCAL, and GWBASIC etc. The programs, written in Assembly Language or any High Level Language are called Source Code.

Object Code:

"A program written in Machine Language is called Object Code."

Computer can understand only machine language code. Language translators converts source code of High Level Language into machine code, these converted codes are Object Codes.

Language Translator:

"Language Translators are programs that convert or translate the instructions in Assembly Language or High Level Language i.e. source code into instructions of machine language i.e. object codes are called Language Translators."

Computer can understand only machine language. Programs written in Assembly Language and High Level Language are translated into Machine Language so as computer can understand execute them.

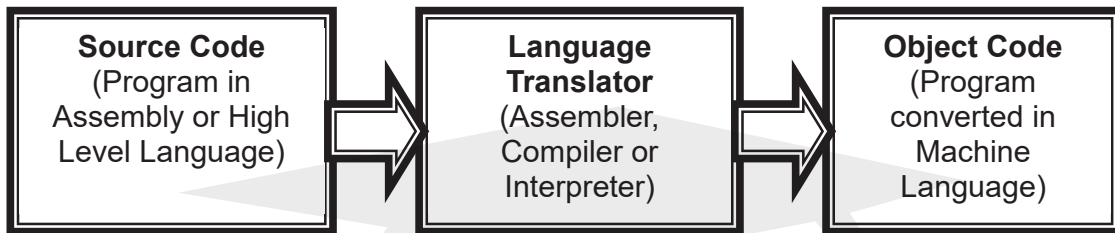

Following are three types of language translators:

1 Assembler:-

"Assembler is a language translator that translates source program written in Assembly Language into object code in machine language."

Computer can understand only machine language. Assemblers translate programs written in Assembly Language into Machine Language so as computer can understand execute them.

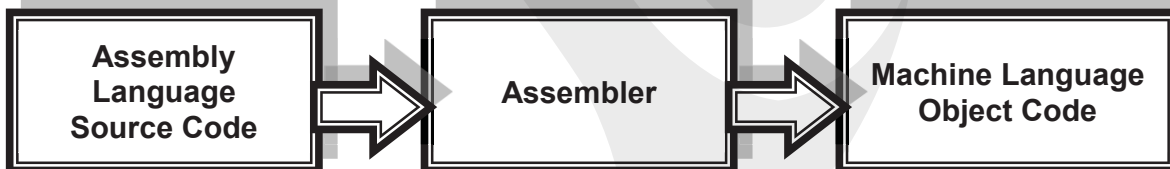
**2 Interpreters:-**

"An interpreter is a language translator that translates source program written in High Level Language into object code in machine language during step by step execution of program."

Computer can only understand instruction written in machine language. Interpreters translate one by one instruction of High Level Language source code into object code of Machine Language.

Interpreter translates one instruction which is executed before translation of next instruction. The object code is not saved so the source code is interpreted every time before the execution.

Each high level language has its own language translator.

**3 Compilers:-**

"A compiler is a language translator that translates whole source program written in High Level

Language into object code in machine language before execution of program."

Compilers translate all instructions before executions. The object code is saved as object file, which is executable. Object files don't need compiler or language for execution.

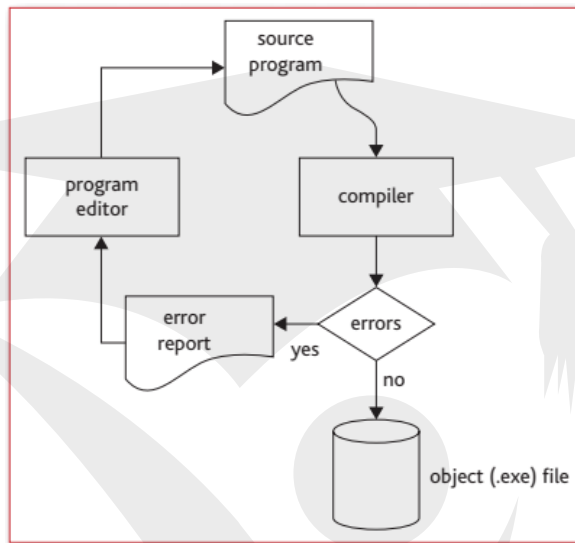
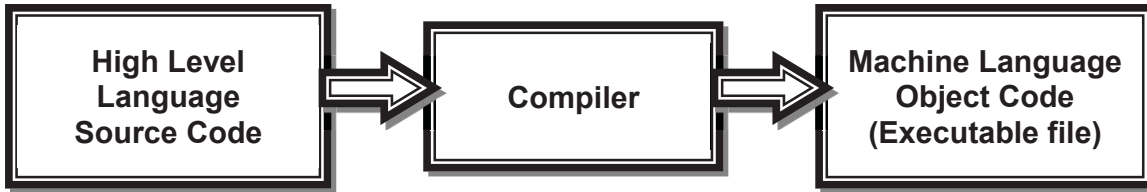

Compiler	Interpreter	Assembler
Translates a high-level language program into machine code.	Executes a high-level language program a statement at a time.	Translates a low-level language program into machine code.
An executable file of machine code is produced.	No executable file of machine code is produced.	An executable file of machine code is produced.
One high-level language statement can be translated into several machine code instructions.	One high-level language program statement may require several machine code instructions to be executed.	One low-level language statement is usually translated into one machine code instruction.
Compiled programs are used without the compiler.	Interpreted programs cannot be used without the interpreter.	Assembled programs can be used without the assembler.
A compiled program is usually distributed for general use.	An interpreter is often used when a program is being developed.	An assembled program is usually distributed for general use.

Syntax errors

An error due to which, a program can't be executed is known as syntax error.

When a program is being compiled, if any syntax errors are found no translated program is produced. Instead, a list of all the errors in the whole program is produced.

When a program is being interpreted, the interpreter performs the actions specified by each statement until a syntax error is found.

Logic errors

Logical errors are the errors which don't stop execution of program but the program don't produced required result.

Run-time error

An **error** that occurs during the execution of a program.

For example, Divide-by-zero error or **running** out of memory will often cause a **runtime error**.

Integrated/Interactive Development Environment (IDE)

Most high-level programming languages offer the use of an IDE for program development. This contains an editor with an interpreter and/or compiler together with debugging tools, which can improve the speed of program development.

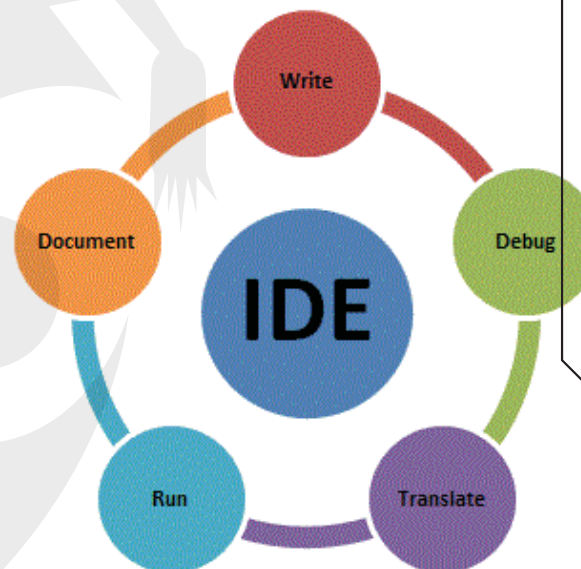

Exam Style Questions:

Q1) A syntax error can occur when writing a program.

(a) State what is meant by a syntax error, giving an example.

.....

.....

.....

.....

..... [2]

(b) Describe tools and facilities available in an integrated development environment (IDE) which can help the programmer to identify and correct syntax errors.

.....

.....

.....

.....

.....

.....

.....

.....

.....

..... [4]

Expected Answer	Mark	Additional Guidance
<ul style="list-style-type: none"> • An error in the rules/grammar of the language • Any suitable example 	[2]	"A spelling error" is acceptable as an example but not as a definition of syntax error. So e.g. "A spelling error such as ED IF instead END IF" is worth 1 mark only.
<ul style="list-style-type: none"> • Error messages/translator diagnostics • Produced when translating/by the compiler • ... or on the fly while writing code • Attempts to tell you what the error is • And indicate where the error is/line numbers/underlines • Editor... • ... allows you to enter the corrected code 	[4]	Translator includes compiler/interpreter

Topical Questions from Past Papers

Q 1) Summer 2015 P11

10 Five statements about interpreters and compilers are shown in the table below. Study each statement. Tick (✓) to show whether the statement refers to an interpreter or to a compiler. [5]

Statement	Interpreter	Compiler
takes one statement at a time and executes it		
generates an error report at the end of translation of the whole program		
stops the translation process as soon as the first error is encountered		
slow speed of execution of program loops		
translates the entire program in one go		

Q 2) Summer 2015 P12

9 (a) Five statements about interpreters and compilers are shown in the table below. Study each statement.

Tick (✓) to show whether the statement refers to an interpreter or to a compiler.

Statement	Interpreter	Compiler
creates an executable file that runs directly on the computer		
more likely to crash the computer since the machine code produced runs directly on the processor		
easier to debug since each line of code is analysed and checked before being executed		
slow speed of execution of program loops		
it is more difficult to modify the executable code, since it is in machine code format		

(b) State why a compiler or an interpreter is needed when running a high-level program on a computer.

.....

[1]

(e) Study the following three sections of code.

A	B	C
1 0 1 0 1 1 0 1	LDA X	FOR x ← 1 TO 10
1 1 0 0 1 1 1 0	INC X	READ n
1 0 1 1 0 1 1 1	STAY	ENDFOR

Identify, using the letters A, B or C, which of the above codes is an example of assembly code, high-level language code or machine code:

Assembly code

High-level language code

Machine code[2]

Q 3) Summer 2016 P12

Complete the following by writing either *compiler*, *interpreter* or *assembler* in the spaces provided.[3]

..... – translates source code into object code.

..... – translates low-level language into machine code.

..... – stops the execution of a program as soon as it encounters an error.

Q 4) Winter 2016 P12

1 (a) Give **two** reasons why a programmer would choose to write code in a low-level language.

1

.....

2

.....

..... [2]

(b) High-level languages require either an interpreter or a compiler to translate the program. The table below lists a number of statements about language translators.

Tick (3) to show which statements refer to interpreters and which refer to compilers. [5]

Statements	Interpreter	Compiler
Translates the source code into machine code all at once		
Produces an executable file in machine code		
Executes a high-level language program one instruction at a time		
Once translated, the translator does not need to be present for the program to run		
An executable file is produced		

Q 5) Winter 2016 P11& 13

6 High-level or low-level languages can be used when writing a computer program. State **two** advantages of using a high-level language and **two** advantages of using a low-level language.

High-level language advantage 1

.....

High-level language advantage 2

.....

Low-level language advantage 1

.....

Low-level language advantage 2

..... [4]

8 Four descriptions about compilers and interpreters are shown below. Draw lines to indicate which descriptions refer to a compiler and which descriptions refer to an interpreter. [4]

Description	
It is more difficult to debug the code since one error can produce many other associated errors.	
The speed of execution of program loops is slower.	Compiler
It produces fast, executable code that runs directly on the processor.	Interpreter
It is easier to debug the code since an error is displayed as soon as it is found.	

Q 8) Winter 2017 P13

10 Six statements about assembly language are shown.

Tick (✓) whether the statement is true or false. [6]

Statement	True (✓)	False (✓)
Assembly language uses mnemonic codes.		
Assembly language programs do not need a translator to be executed.		
Assembly language is a low-level programming language.		
Assembly language is specific to the computer hardware.		
Assembly language is machine code.		
Assembly language is often used to create drivers for hardware.		

Q 6) March 2017 India

11 Three programmers are working on different projects:

- Alice is developing a program written in a low-level language
- Akbar is developing a program written in a high-level language
- Alex is preparing a program written in a high-level language for sale

State, with reasons, which type of translator each programmer should use. Each programmer should be using a different type of translator.

Alice

Akbar

Alex [6]

Q 7) Summer 2017 P11

2 Programmers can use a high-level language to write a computer program.

(a) Explain what is meant by the term 'high-level language'.

..... [2]

(b) A program written in a high-level language is translated into machine code. This is so that it can be processed by a computer. Name one type of translator that can be used.

..... [1]

(c) Describe how your answer to **part (b)** translates this program.

..... [3]

Q 9) Summer 2018 P11

7 Translators, such as a compiler and an interpreter, are used when writing and running computer programs. Describe how a compiler and an interpreter translates a computer program.

Compiler

.....

.....

.....

.....

Interpreter

.....

.....

.....

.....

..... [6]

Q 10) Summer 2018 P12

8 Dimitri is writing a computer program in a high-level language. He needs to send just the machine code for the program to his friend, electronically. It is important that the program is executed as quickly as possible. Identify which translator will be most suitable for Dimitri to use. Explain your choice.

Type of translator

Explanation

.....

.....

.....

.....

..... [4]

Q 11) Winter 2018 P12

6 (a) Many programmers write computer programs in high-level languages. The programs need to be translated into machine code to be read by the computer.

State **two** types of translator that can be used.

Translator 1

Translator 2 [2]

(b) Explain **two** reasons why a computer programmer may choose to write a program in a high level language, rather than a low-level language.

Reason 1

.....
.....
.....

Reason 2

.....
.....
..... [4]

Q 12) Winter 2018 P13

7 David is writing a program using a high-level language. The program will be published and sold for profit.

(a) David uses an interpreter when creating the computer program. State three features of an interpreter.

Feature 1

.....
.....
.....

Feature 2

.....
.....
.....

Feature 3

.....
..... [3]

(b) David compiles the program when he has completed it. Explain two benefits of compiling the program.

Benefit 1

.....

.....

.....

Benefit 2

.....

.....

..... [4]

Q 13) March 2019 P12

4 Darius is writing a computer program that allows binary values to be calculated.

Darius chooses to write the program in a high-level language rather than a low-level language.

(a) Explain why Darius chooses to write the program in a high-level language.

.....

.....

..... [2]

(b) Darius will use a translator to translate the program. He could use a compiler or an interpreter.

Five statements are given about compilers and interpreters.

Tick (✓) to show if the statement applies to a **Compiler** or an **Interpreter**. Statements may apply to both. [5]

Statement	Compiler (✓)	Interpreter (✓)
A report of errors is produced at the end of translation.		
The program is translated one line at a time.		
The program is translated from high-level language into machine code.		
An executable file is produced.		
The program will not run at all if an error is detected.		

Q 14) Summer 2019 P11

7 Annie writes a paragraph of text as an answer to an examination question about programming languages. Using the list given, complete Annie’s answer by inserting the correct **six** missing terms. Not all terms will be used.

- Assembly • Converter • Denary • Hexadecimal
- High-level language • Low-level language • Machine Code • Source Code
- Syntax • Translator

The structure of language statements in a computer program is called the

A programming language that uses natural language statements is called a

When programs are written in this type of language they need a to convert them into

A programming language that is written using mnemonic codes is called language. This is an example of a [6]

Q 15) Winter 2019 P13) 2 A programmer uses a high-level language to write a computer program. [4]

(a) **Four** statements are given about high-level programming languages. **Tick** to show **True** or **False**.

Statement	True	False
High-level languages need to be translated into machine code to run on a computer		
High-level languages are written using mnemonic codes		
High-level languages are specific to the computer’s hardware		
High-level languages are portable languages		

Q 16) March 20 P12) 4 Assemblers, compilers and interpreters are types of translators. [5]

Tick (✓) to show which statements apply to each translator. Each statement may apply to more than one type of translator.

Statement	Assembler	Compiler	Interpreter
Translates low-level language to machine code			
Translates high-level language to machine code			
Produces error messages			
Translates high-level language one line at a time			

Produces an executable file			
-----------------------------	--	--	--

Q 17) Summer 20 P12

2 Both an interpreter and a compiler can be used when writing a program in a high-level language.

(a) Explain why a programmer would make use of both an interpreter **and** a compiler.

.....
.....
.....
.....
.....

[4]

(b) Give **three** reasons why a programmer would choose to write a program in a high-level language, instead of a low-level language.

Reason 1

Reason 2

Reason 3

.....

[3]

Q 18) 15a Summer 20 P11) 9 Programs can be written in a low-level language.

(a) Identify **three** features of a low-level language.

Feature 1

Feature 2

Feature 3

[3]

(b) Give **two** examples of a low-level language.

Example 1

Example 2

[2]

(c) Give **one** drawback of writing programs in a low-level language.

.....
.....

[1]

18c Summer 21 P13) 5 Six statements are given about programming languages.

Tick (✓) to show whether each statement applies to high-level language, assembly language or machine code. Some statements may apply to more than one type of programming language. [6]

Statement	High-level language (✓)	Assembly language (✓)	Machine code (✓)
it requires a translator to be processed by a computer			
it is an example of low-level language			
it uses mnemonics			
it uses English-like statements			
it can be used to directly manipulate hardware in the computer			
it is portable			

5	One mark per each correct row				6
	Statement	High-level language (✓)	Assembly language (✓)	Machine code (✓)	
	It requires a translator to be processed by a computer	✓	✓		
	It is an example of low-level language		✓	✓	
	It uses mnemonics		✓		
	It uses English-like statements	✓			
	It can be used to directly manipulate hardware in the computer		✓	✓	
	It is portable	✓			

Marking Scheme

10 1 mark per correctly placed tick

statement	interpreter	compiler
takes one statement at a time and executes it	✓	
generates an error report at the end of translation of the whole program		✓
stops the translation process as soon as the first error is encountered	✓	
slow speed of execution of program loops	✓	
translates the entire program in one go		✓

Q 2) Summer 2015 P12

Page 10	Mark Scheme	Syllabus	Paper
	Cambridge O Level – May/June 2015	2210	12

9 (a) 1 mark per correctly placed tick

statement	interpreter	compiler
creates an executable file that runs directly on the computer		✓
more likely to crash the computer since the machine code produced runs directly on the processor		✓
easier to debug since each line of code is analysed and checked before being executed	✓	
slow speed of execution of program loops	✓	
it is more difficult to modify the code since the executable code is now in machine code format		✓

[5]

(b) Any **one** from:

- code is required to be converted into machine code/binary
- code needs to be produced that can be understood by the computer

[1]

(c) Any **one** from:

- close to English/native/human language
- easier/faster to correct errors/read/write
- works on many different machines/operating systems (portable)

[1]

(d) Any **one** from:

- work directly on registers/CPU
- more control over what happens in computer
- can use machine specific functions

[1]

(e) 1 mark per correct letter, maximum 2 marks

- Assembly code: **B**
 High-level language code: **C**
 Machine code: **A**

[2]

Q 3) Summer 2016 P12

- 1 compiler
 assembler
 interpreter

[3]

Q 4) Winter 2016 P12

1 (a) Any **two** from:

- direct access to computer processor / special hardware // machine dependent instructions
- uses up less memory
- can increase the speed of processing a program // executes instructions faster

[2]

(b)

Statements	Interpreter (✓)	Compiler (✓)
Translates the source code into machine code all at once		✓
Produces an executable file in machine code		✓
Executes a high-level language program one instruction at a time	✓	
Once translated, the translator does not need to be present for the program to run		✓
An executable file is produced		✓

[5]

Q 5) Winter 2016 P11& 13

6 Any **two** from:

High level language

- easier/faster to write code as uses English-like statements
- easier to modify as uses English-like statements
- easier to debug as uses English-like statements
- portable language code

Any **two** from:

Low level language

- can work directly on memory locations
- can be executed faster
- translated program requires less memory

[4]

7 Any **four** from:

- reaches maximum brightness quickly
- colours are vivid
- good colour definition/contrast can be achieved
- screens can be thinner/thin
- more reliable as LED's are long lasting
- consume very little/less energy

[4]

Page 7	Mark Scheme	Syllabus	Paper
	Cambridge IGCSE – October/November 2016	0478	13

8

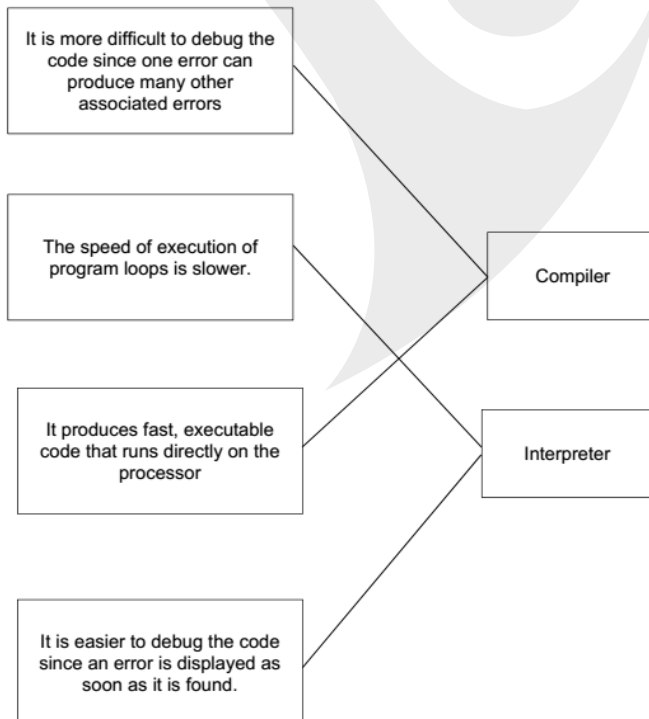

[4]

Q 6) March 2017 India

Question	Answer	Marks
11	<p>Alice</p> <ul style="list-style-type: none"> ∞ Assembler ∞ translates low level language into machine code / only option for low-level language programs <p>Akbar</p> <ul style="list-style-type: none"> ∞ Interpreter ∞ easy to identify where an error is / to debug a program <p>Alex</p> <ul style="list-style-type: none"> ∞ Compiler ∞ once translated a stand-alone program file is created / no need for the compiler when running the program 	6

Q 7) Summer 2017 P11

Question	Answer	Marks
2(a)	<p>Two from:</p> <ul style="list-style-type: none"> ∞ Closer to human language // closer to English ∞ Independent of a particular type of computer/device/platform // portable language ∞ A language such as Python, Java, Pascal, etc. (any suitable example) 	2
2(b)	<p>One from:</p> <ul style="list-style-type: none"> ∞ Compiler ∞ Interpreter 	1
2(c)	<p>Must relate to answer given in 2b. No follow through for incorrect answer in part 2b.</p> <p>Compiler – Three from:</p> <ul style="list-style-type: none"> ∞ Translates the whole program as a complete unit / at once ∞ Creates an executable file / object code ∞ A report / list of errors in the code is created ∞ Optimises the source code (to run efficiently) <p>Interpreter – Three from:</p> <ul style="list-style-type: none"> ∞ Translates a program one line of code at a time ∞ Machine code is directly executed // The interpreter is used each time the program / code is executed ∞ Will identify an error as soon as it finds one in a line of code 	3

Q 8) Winter 2017 P13

Question	Answer	Marks																					
10	<p>1 mark for each correct tick</p> <table border="1"> <thead> <tr> <th>Statement</th> <th>true (✓)</th> <th>false (✓)</th> </tr> </thead> <tbody> <tr> <td>Assembly language uses mnemonic codes.</td> <td>✓</td> <td></td> </tr> <tr> <td>Assembly language programs do not need a translator to be executed.</td> <td></td> <td>✓</td> </tr> <tr> <td>Assembly language is a low-level programming language.</td> <td>✓</td> <td></td> </tr> <tr> <td>Assembly language is specific to the computer hardware.</td> <td>✓</td> <td></td> </tr> <tr> <td>Assembly language is machine code.</td> <td></td> <td>✓</td> </tr> <tr> <td>Assembly language is often used to create drivers for hardware.</td> <td>✓</td> <td></td> </tr> </tbody> </table>	Statement	true (✓)	false (✓)	Assembly language uses mnemonic codes.	✓		Assembly language programs do not need a translator to be executed.		✓	Assembly language is a low-level programming language.	✓		Assembly language is specific to the computer hardware.	✓		Assembly language is machine code.		✓	Assembly language is often used to create drivers for hardware.	✓		6
Statement	true (✓)	false (✓)																					
Assembly language uses mnemonic codes.	✓																						
Assembly language programs do not need a translator to be executed.		✓																					
Assembly language is a low-level programming language.	✓																						
Assembly language is specific to the computer hardware.	✓																						
Assembly language is machine code.		✓																					
Assembly language is often used to create drivers for hardware.	✓																						

Q 9) Summer 2018 P11

Question	Answer	Marks
7	<p>Compiler</p> <p>Any three from:</p> <ul style="list-style-type: none"> - Translates high-level language into machine code/low level language - Translates (the source code) all in one go/all at once - Produces an executable file - Produces an error report <p>Interpreter</p> <p>Any three from:</p> <ul style="list-style-type: none"> - Translates high-level language into machine code/low level language - Translates (the source code) line by line/statement by statement - Stops if it finds an error - Will only continue when error is fixed 	6

Q 10) Summer 2018 P12

8	<p>1 mark for correct translator, 3 marks for explanation:</p> <ul style="list-style-type: none"> - Compiler <p>Any three from:</p> <ul style="list-style-type: none"> - Does not require recompilation // compiled program can be executed without a compiler ... - ... therefore, allows faster execution - Provides an executable file ... - ... therefore, allows him to just send machine code - Dimitri's friend does not need translation/compilation software to execute the program 	4
---	---	---

Q 11) Winter 2018 P12

Question	Answer	Marks
6(a)	<ul style="list-style-type: none"> α Compiler ∞ Interpreter 	2
6(b)	<p>Four from:</p> <ul style="list-style-type: none"> ∞ Closer to human language/English ... ∞ ... so it is easier/quicker to read/write/understand ∞ ... so it is easier/quicker to debug the program ∞ ... therefore, less likely to make errors ∞ The program can be used on many different platforms ... ∞ ... because it is written in source code ∞ ... because it is compiled into object code ∞ They have built-in functions/libraries ... ∞ ... this saves time when writing the program ∞ Do not need to manipulate memory addresses directly ... ∞ ... therefore, specialist knowledge of this is not required ∞ Only need to learn a single language ... ∞ ... as this can be used on many different computers 	4

Question	Answer				Marks
6(c)	1 mark for each correct tick (✓)				3
	Computer code	High-level language (✓)	Assembly language (✓)	Machine code (✓)	
	10110111 11001100 01011100			✓	
	FOR X = 1 TO 10 PRINT X NEXT X	✓			
	INP X STA X LDA Y		✓		

Q 12) Winter 2018 P13

Question	Answer	Marks
7(a)	Three from: <ul style="list-style-type: none"> ∞ It is a translator ∞ Translates (high level language) to low level language ∞ Executes one line at a time ∞ Translates source code line by line ∞ Runs error diagnostic ∞ Produces error messages to tell user location of error ∞ Stops execution when encounters errors ∞ Continues translating when an error is fixed 	3
7(b)	Four from (Max three per benefit): <ul style="list-style-type: none"> ∞ Produces executable file ... ∞ ... this creates a smaller file size ∞ ... more saleable ∞ Program will be machine independent / portable ... ∞ ... this means it can be used on any hardware ∞ No need for compiler to run executable file ... ∞ ... this means it will be quicker to run ∞ ... customers can just execute the program ∞ Source code cannot be accessed ... ∞ ... therefore, code cannot be stolen / plagiarised 	4
7(c)	Three from: <ul style="list-style-type: none"> ∞ Uses compression algorithm / by example e.g. RLE ∞ Repeating words / phrases / patterns identified... ∞ ... replaced with value ∞ File / dictionary / index of phrases created ∞ Index will store word/phrase with value 	3

Q 13) March 2019 P12

4(a)	Two from: - Closer to English statements / human language - Easier / quicker to write / read / understand / remember - Easier / quicker to debug - Less likely to make errors - One line of code can carry out multiple commands - Portable language	2																		
4(b)	1 mark for correct tick(s) for each statement <table border="1" style="margin-left: 20px;"> <thead> <tr> <th>Statement</th> <th>Compiler</th> <th>Interpreter</th> </tr> </thead> <tbody> <tr> <td>A report of errors is produced at the end of translation</td> <td style="text-align: center;">✓</td> <td></td> </tr> <tr> <td>The program is translated one line at a time</td> <td></td> <td style="text-align: center;">✓</td> </tr> <tr> <td>The program is translated from high-level language into machine code</td> <td style="text-align: center;">✓</td> <td style="text-align: center;">✓</td> </tr> <tr> <td>An executable file is produced</td> <td style="text-align: center;">✓</td> <td></td> </tr> <tr> <td>The program will not run at all if an error is detected</td> <td style="text-align: center;">✓</td> <td></td> </tr> </tbody> </table>	Statement	Compiler	Interpreter	A report of errors is produced at the end of translation	✓		The program is translated one line at a time		✓	The program is translated from high-level language into machine code	✓	✓	An executable file is produced	✓		The program will not run at all if an error is detected	✓		5
Statement	Compiler	Interpreter																		
A report of errors is produced at the end of translation	✓																			
The program is translated one line at a time		✓																		
The program is translated from high-level language into machine code	✓	✓																		
An executable file is produced	✓																			
The program will not run at all if an error is detected	✓																			
4(c)	- Lossy would remove data - Lossless does not remove data // No data can be lost ... - Can be restored to original state ... - ... otherwise will not run / work correctly	4																		
4(d)(i)	- Sending device creates value from calculation on data // By example - Value is transmitted with the data - Receiving device performs same calculation - Values are compared after transmission // If values do not match ... - ... an error is detected	5																		
4d(ii)	- Parity check - Check digit - Automatic repeat request	3																		

Q 14) Summer 2019 P11

7	1 mark for each correct term, in the correct place: <ul style="list-style-type: none"> • Syntax • High-level language • Translator • Machine code • Assembly • Low-level language 	6
---	---	---

Q 15) Winter 2019 P13

2210/13

Cambridge O Level – Mark Scheme
PUBLISHED

October/November 2019

Question	Answer	Marks															
2(a)	<p>One mark for each correct row</p> <table border="1"> <thead> <tr> <th>Statement</th> <th>True (✓)</th> <th>False (✓)</th> </tr> </thead> <tbody> <tr> <td>High-level languages need to be translated into machine code to run on a computer</td> <td>✓</td> <td></td> </tr> <tr> <td>High-level languages are written using mnemonic codes</td> <td></td> <td>✓</td> </tr> <tr> <td>High-level languages are specific to the computer's hardware</td> <td></td> <td>✓</td> </tr> <tr> <td>High-level languages are portable languages</td> <td>✓</td> <td></td> </tr> </tbody> </table>	Statement	True (✓)	False (✓)	High-level languages need to be translated into machine code to run on a computer	✓		High-level languages are written using mnemonic codes		✓	High-level languages are specific to the computer's hardware		✓	High-level languages are portable languages	✓		4
Statement	True (✓)	False (✓)															
High-level languages need to be translated into machine code to run on a computer	✓																
High-level languages are written using mnemonic codes		✓															
High-level languages are specific to the computer's hardware		✓															
High-level languages are portable languages	✓																

2210/13

Cambridge O Level – Mark Scheme
PUBLISHED

October/November 2019

Question	Answer	Marks								
2(b)	<p>One mark for the correct tick</p> <table border="1"> <thead> <tr> <th>Example program</th> <th>Tick (✓)</th> </tr> </thead> <tbody> <tr> <td>1011100000110000 0000011011100010</td> <td></td> </tr> <tr> <td>INP STA ONE INP STA TWO ADD ONE</td> <td></td> </tr> <tr> <td>a = input() b = input() if a == b: print("Correct") else: print("Incorrect")</td> <td>✓</td> </tr> </tbody> </table>	Example program	Tick (✓)	1011100000110000 0000011011100010		INP STA ONE INP STA TWO ADD ONE		a = input() b = input() if a == b: print("Correct") else: print("Incorrect")	✓	1
Example program	Tick (✓)									
1011100000110000 0000011011100010										
INP STA ONE INP STA TWO ADD ONE										
a = input() b = input() if a == b: print("Correct") else: print("Incorrect")	✓									

Q 16) March 20 P12

Question	Answer	Mark																								
4	<table border="1"> <thead> <tr> <th>Statement</th> <th>Assembler (✓)</th> <th>Compiler (✓)</th> <th>Interpreter (✓)</th> </tr> </thead> <tbody> <tr> <td>Translates low-level language to machine code</td> <td>✓</td> <td></td> <td></td> </tr> <tr> <td>Translates high-level language to machine code</td> <td></td> <td>(✓)</td> <td>✓</td> </tr> <tr> <td>Produces error messages</td> <td>(✓)</td> <td>✓</td> <td>✓</td> </tr> <tr> <td>Translates high-level language one line at a time</td> <td></td> <td></td> <td>✓</td> </tr> <tr> <td>Produces an executable file</td> <td>(✓)</td> <td>✓</td> <td></td> </tr> </tbody> </table> <p>1 mark per each correct row: NOTE: tick shown in brackets (✓) is optional</p>	Statement	Assembler (✓)	Compiler (✓)	Interpreter (✓)	Translates low-level language to machine code	✓			Translates high-level language to machine code		(✓)	✓	Produces error messages	(✓)	✓	✓	Translates high-level language one line at a time			✓	Produces an executable file	(✓)	✓		5
Statement	Assembler (✓)	Compiler (✓)	Interpreter (✓)																							
Translates low-level language to machine code	✓																									
Translates high-level language to machine code		(✓)	✓																							
Produces error messages	(✓)	✓	✓																							
Translates high-level language one line at a time			✓																							
Produces an executable file	(✓)	✓																								

Q 17) Summer 20 P12

Question	Answer	Marks
2(a)	Any four from: <ul style="list-style-type: none"> - To translate the high-level language into low-level language - Interpreter used whilst writing the program - Interpreter used to debug code line by line - Compiler used when program completed - Compiler used to create separate executable file (so compiler no longer needed) - If it runs first time in a compiler there are no syntax errors 	4
2(b)	Any three from: <ul style="list-style-type: none"> - Easier to understand // Don't know assembly code - Easier to debug - Easier to maintain - Portable - Knowledge of manipulating memory locations/registers not required - Can use an IDE - Greater range of languages 	3

Q 18) 15a Summer 20 P11

9(a)	Any three from: <ul style="list-style-type: none"> - Closer to/is machine code - May use mnemonics - May need an assembler to be translated - One line of code represents a single instruction - Machine dependent - Have direct access to memory locations/registers 	3
9(b)	<ul style="list-style-type: none"> - Assembly code - Machine code 	2
9(c)	Any one from: <ul style="list-style-type: none"> - It is more difficult to understand - Error prone - Have to manipulate memory locations - Machine dependent 	1

Q 19) March 21 P12

7(a)	Any two from: <ul style="list-style-type: none"> - Makes use of words // close to human language - Machine independent // portable - Problem / logic focussed - Needs to be translated/interpreter/compiled (to low-level for processing by computer) // needs converting to machine code 	2
------	--	---

7(b)	<p>Four from Max 2 for only giving compiler/interpreter features</p> <ul style="list-style-type: none">- Both translate high level / source code to machine code- Both generate error diagnostics/messages // identify errors - Interpreter translates one line at a time // checks one line and then runs it- Compiler translates whole code in one go // checks all code and then runs it - Interpreter stops when meets an error- ...and then allows you to continue running from where you stopped // correct errors in real-time- Compiler provides list of all errors - Interpreter does not produce an executable file- Compiler produces an executable file	4
------	--	---

Chapter 4

1.4 Security aspects



Learning Outcome	To Read	Have Read	To Revise	Have	Prepared
1.2.2: Security aspects					
Show understanding of the security aspects of using the Internet and understand what methods are available to help minimise the risks					
Show understanding of the Internet risks associated with malware, including viruses, spyware and hacking					
Explain how anti-virus and other protection software helps to protect the user from security risks (this also links into section 1.4 of the syllabus)					
1.4 Data integrity and security					
Show understanding of how data are kept safe when stored and transmitted, including: <ul style="list-style-type: none"> o use of passwords, both entered at a keyboard and biometric o use of firewalls, both software and hardware, including proxy servers o use of security protocols such as Secure Socket Layer (SSL) and Transport Layer Security (TLS) o use of symmetric encryption (plain text, cypher text and use of a key) showing understanding that increasing the length of a key increases the strength of the encryption 					
Show understanding of the need to keep online systems safe from attacks including denial of service attacks, phishing, pharming					
Show understanding of the need to keep data safe from accidental damage, including corruption and human errors					

Learning Outcome	To Read	Have Read	To Revise	Have	Prepared
Show understanding of the need to keep data safe from malicious actions, including unauthorised viewing, deleting, copying and corruption					
Describe how the knowledge from 1.4.1, 1.4.2 and 1.4.3 can be applied to real-life scenarios including, for example, online banking, shopping					

Data Integrity and security

Data integrity refers to maintaining and assuring the accuracy and **consistency** of **data** over its entire life-cycle, and is a critical aspect to the design, implementation and usage of any system which stores, processes, or retrieves **data**.

Data security is about keeping data safe. Many individuals, small businesses and major companies rely heavily on their computer systems.

If the data on these computer systems is damaged, lost, or stolen, it can lead to disaster.



Loss of Data

Data loss is any process or event that results in data being corrupted, deleted and/or made unreadable by a user and/or software or application. It occurs when one or more data elements can no longer be utilized by the data owner or requesting application. Data loss is also known as data leakage.

Reason	Pre-caution/ Method of Recovery
Accidental deletion	<ul style="list-style-type: none"> • Back-up • Saving on regular basis • Use of password so as unauthorised person can't delete data.
Hardware failure	<ul style="list-style-type: none"> • Back-up • UPS (to prevent loss of data from power failure) • Saving on regular basis • Parallel back-up hardware
Software failure	<ul style="list-style-type: none"> • Back-up • Saving on regular basis
Incorrect computer operation	<ul style="list-style-type: none"> • Back-up • Shut down computer properly • Remove external storage properly
Natural Disaster	<ul style="list-style-type: none"> • Back-up

Computer virus is program or code that replicates itself and is designed to amend, delete or copy data and files on a user's computer without their consent.

Viruses are developed with intention to harm other computer data and programs.

Worms and Trojan horse are also types of virus.

A **worm** is a program that *actively* transmits itself over a network to infect other computers.

A **Trojan** horse is any program that invites the user to run it, concealing harmful or malicious code.

A **Trojan** horse is any program that invites the user to run it, concealing harmful or malicious code.

Security Risk:

- Can delete or corrupt data and programs
- Can disrupt computer,
- Can cause computer stop working "hung"

Methods to remove risk

- Install antivirus
- Download data/programs only from authentic source
- Scan before opening email attachments or data from external source
- Install firewall

Spyware

Spyware/key-logging is software that monitors key presses on a user's keyboard, and relays the information back to the person who sent the software.

Spyware is a form of malware that hides on your device, monitors your activity, and steals sensitive information like bank details and passwords.

Security Risk:

- Transmits all data typed by user to the originator of spyware e.g. email/bank id and passwords, debit/credit card number etc.
- Can read cookies.
- Can change default web browser
- Can install other spyware

Methods to remove risk

- Install anti-spyware software
- Install firewall
- Use on-screen keyboard to type user id and passwords



War Driving

War driving is the act of searching for Wi-Fi wireless networks by a person usually in a moving vehicle, using a laptop or Smartphone. It is also known as **Access-Point Mapping**.

Security Risk

- Uses user's internet data/time
- May hack password and personal data

Methods to remove risk

- Use complex password
- Limit the number of users
- Firewall
- Use wired equivalent privacy (WEP) encryption

Phishing

Phishing is the act of attempting to acquire sensitive information like usernames, passwords and credit card details by disguising as a trustworthy source. Phishing is carried out through emails or by luring the users to enter personal information through fake websites. Criminals often use websites that have a look and feel of some popular website, which makes the users feel safe to enter their details there.

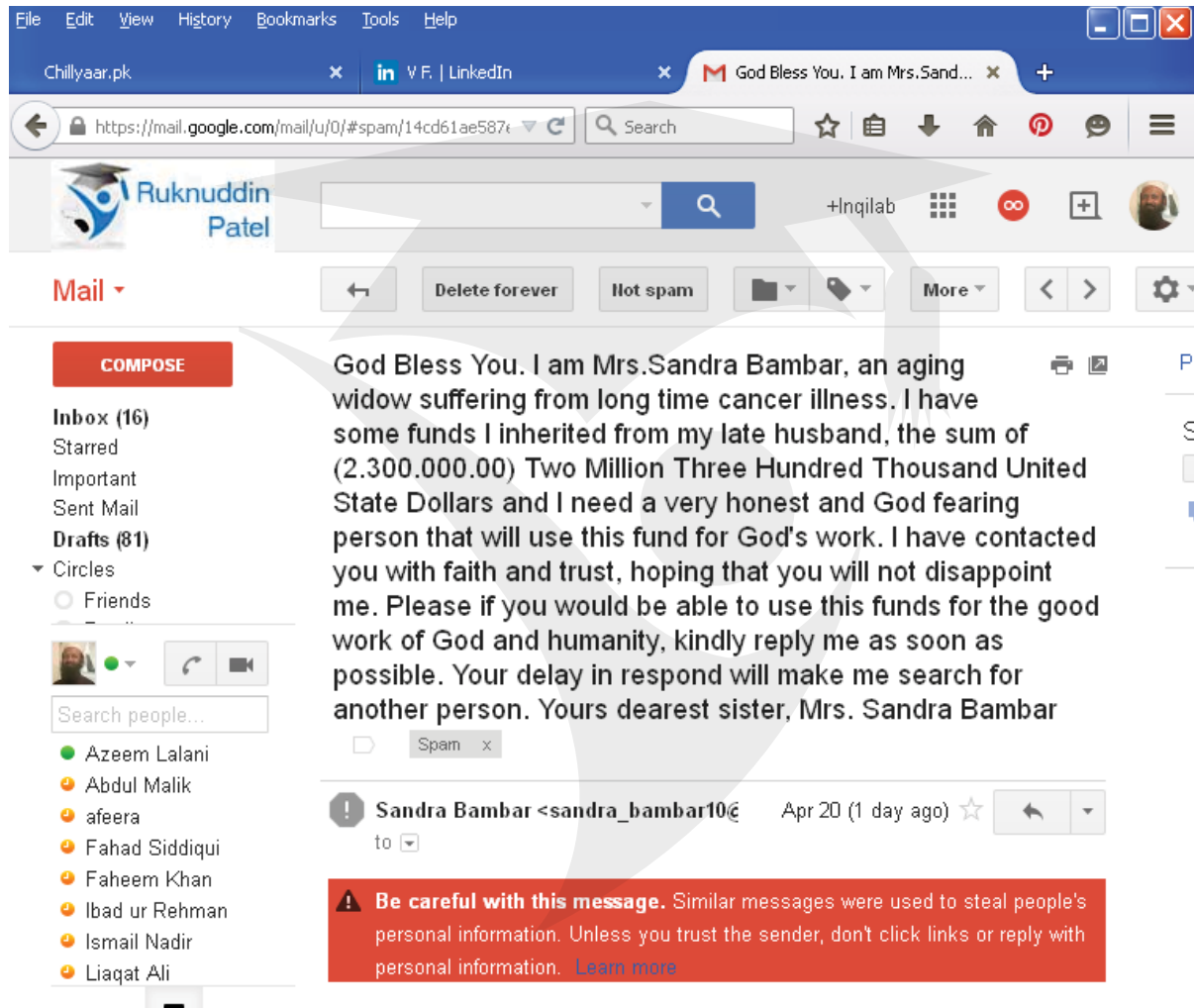

Protection

1. The most powerful weapon against phishing is common sense and the following rules that every user should oblige to.
2. If you are not a customer of the site delete the email immediately. Don't click on the link or reply.
3. If you are a customer and you are not sure if the email is legit do one of the following:
 - a) Contact the institute by phone or contact at the official website (do not use the email link of course) and ask if the mail is official.
 - b) Instead of using the link provided open the website by typing in the official link there. The site

should have news about the email on their starting page. (Most of the time). If not, use 3a to verify the email.

Pharming:

Pharming in Simple Steps:

- Hacker creates a fake website which appears similar to the original website.
- Hacker poisons the DNS servers thus domain names are resolved into fake IP address.
- User types the URL of the original website in the browser.
- The DNS server directs User to the fake website designed by hacker.
- User not knowing that it is a fake website, shares his confidential information such as login, password etc.
- Hacker gets the user confidential information from his fake web site and uses it to access the original website.
- Hacker exploits user's confidential information to his liking.

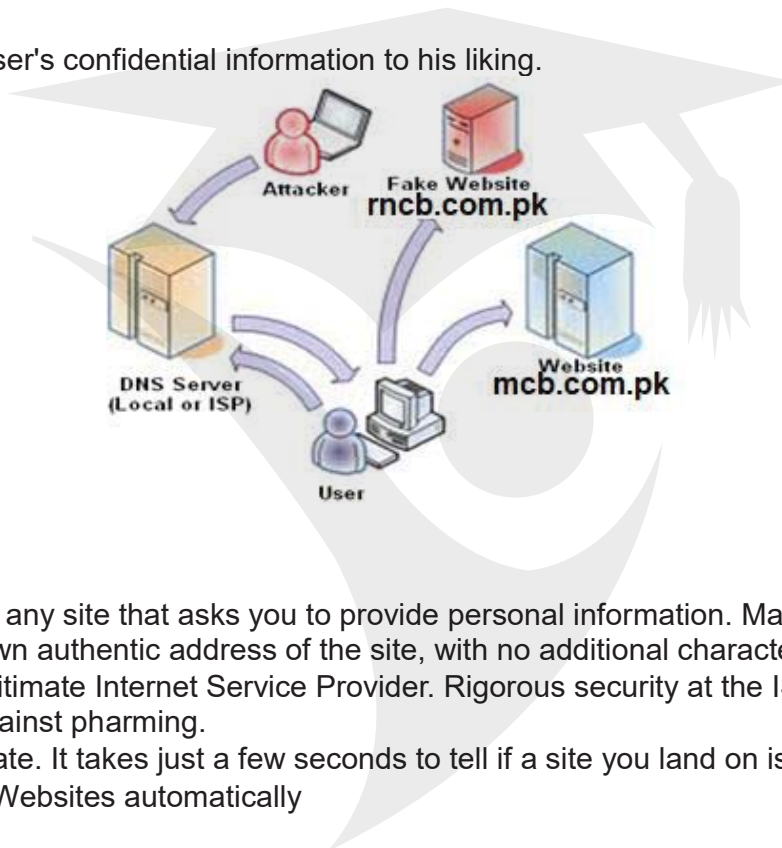

Protection

- Check the URL of any site that asks you to provide personal information. Make sure your session begins at the known authentic address of the site, with no additional characters appended to it.
- Use a trusted, legitimate Internet Service Provider. Rigorous security at the ISP level is your first line of defense against pharming.
- Check the certificate. It takes just a few seconds to tell if a site you land on is legitimate.
- Block suspicious Websites automatically

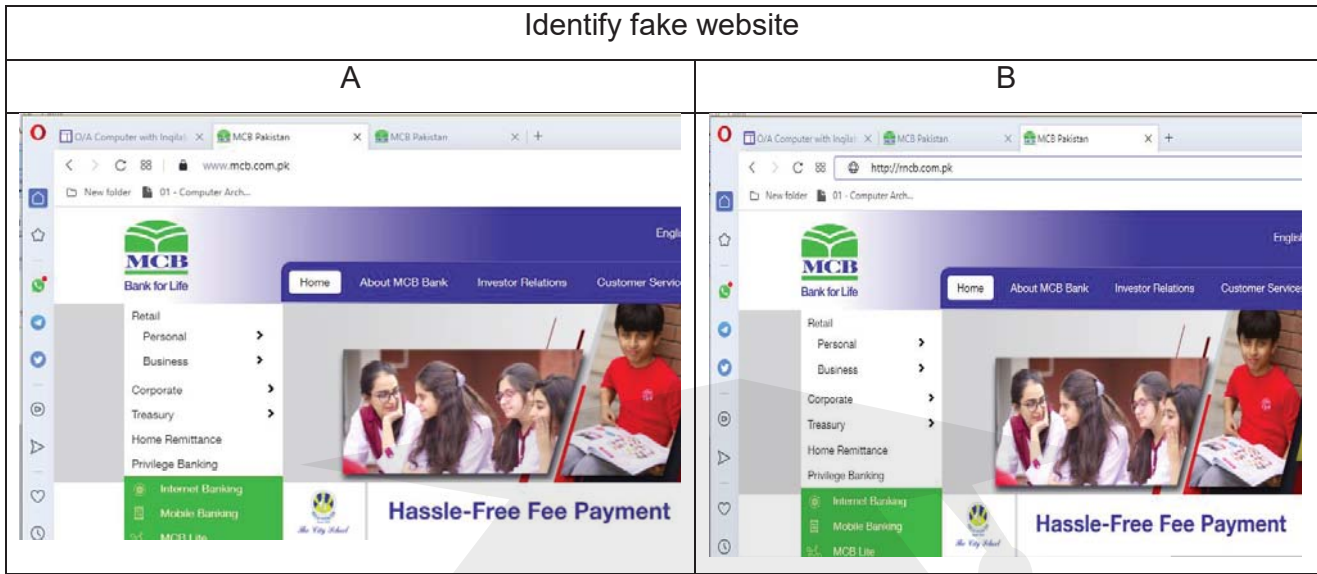

Differences between Phishing and Pharming

S No	Phishing	Pharming

Hacking

Hacking is unauthorized use of computer and network resources.

The activity of breaking into a computer system to gain an unauthorized access is known as hacking. The act of defeating the security capabilities of a computer system in order to obtain an illegal access to the information stored on the computer system is called hacking.

Protection:

- Make your passwords long and complicated, and with a good mix of letters and numbers, as well as utilizing case-sensitive letters. Don't use anything familiar, such as your birthday, your children's names or anything like that. If a hacker wants to attempt to break into your email accounts, at least make him work for it.
- Don't ever allow your browser to remember your passwords. True, it may be a bit of an inconvenience to enter your password every time you log in.
- Activate Firewall

Firewall

a firewall is a network security system that monitors and controls incoming and outgoing network traffic based on predetermined security rules. A firewall typically establishes a barrier between a trusted internal network and un-trusted external network, such as the Internet.

Firewalls can be implemented as both hardware and software, or a combination of both. Network firewalls are frequently used to prevent unauthorized Internet users from accessing private networks connected to the Internet, especially *intranets*. All messages entering or leaving the intranet pass through the firewall, which examines each message and blocks those that do not meet the specified security criteria.

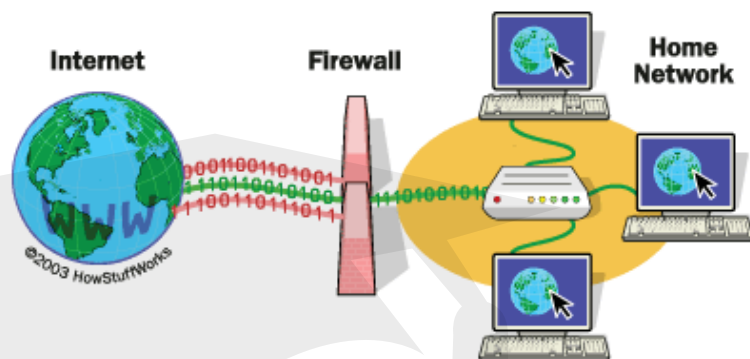

Functions of firewall

- Monitors incoming and outgoing traffic
- checking whether incoming or outgoing data meets a given set of criteria
- if the data fails the criteria, the firewall will block the 'traffic' and give the user(or network manager) a warning that there may be a security issue
- logging all incoming and outgoing 'traffic' to allow later interrogation by the user(or network manager)
- criteria can be set to prevent access to certain undesirable sites; the firewall can keep a list of all undesirable IP addresses
- helping to prevent viruses or hackers entering the user's computer (or internal network)
- warning the user if some software on their system is trying to access an external data source (e.g. automatic software upgrade); the user is given the option of allowing it to go ahead or requesting that such access is denied.

It is often referred to in this case as a **GATEWAY**. Alternatively, the firewall can be software installed on a computer; in some cases, this is part of the operating system.

Limitations of firewall

- it cannot prevent individuals, on internal networks, using their own modems to bypass the firewall
- employee misconduct or carelessness cannot be controlled by firewalls (for example, control of passwords or use of accounts)
- users on stand-alone computers can chose to disable the firewall, leaving their computer open to harmful 'traffic' from the internet.
- All of these issues require management control or personal control (on a single computer) to ensure that the firewall is allowed to do its job effectively.

Proxy server

A proxy server is a dedicated computer system running on a network that acts as an intermediary between a client application, such as a Web browser, and a real server.

how proxy servers work:

When a proxy server receives a request for an Internet resource (such as a Web page), it looks in its local cache of previously pages. If it finds the page, it returns it to the user without needing to forward the request to

the Internet. If the page is not in

the cache, the proxy server, acting as a client on behalf of the user, uses one of its own IP addresses to request the page from the server out on the Internet. When the page is returned, the proxy server relates it to the original request and forwards it on to the user.



Functions of proxy servers include:

- allowing the internet 'traffic' to be filtered; they can block access to a website if necessary (similar type or reaction as a firewall)
- by using the feature known as a **CACHE**, they can speed up access to information from a website; when the website is first visited, the home page is stored on the proxy server; when the user next visits the website, it now goes through the proxy server cache instead, giving much faster access
- keeping the user's IP address secret – this clearly improves security
- acting as a firewall.

Security Certificates



US-CERT

UNITED STATES COMPUTER EMERGENCY READINESS TEAM

<https://www.us-cert.gov/ncas/tips/ST04-014>

If an organization wants to have a secure web site that uses encryption, it needs to obtain a site, or host, certificate.

There are two elements:

- a closed padlock,
- URL that begins with "https:" rather than "http:"

If a web site has a valid certificate, it means that a certificate authority has taken steps to verify that the web address actually belongs to that organization. When you type a URL or follow a link to a secure web site, your browser will check the certificate for the following characteristics:

1. The web site address matches the address on the certificate
2. The certificate is signed by a certificate authority that the browser recognizes as a "trusted" authority

If the browser senses a problem, it may present you with a dialog box that claims that there is an error with the site certificate.

If you have chosen not to trust the company who issued the certificate, or if the certificate has expired. You will usually be presented with the option to examine the certificate, after which you can accept the certificate forever, accept it only for that particular visit, or choose not to accept it.





Security protocols

There are two forms of security protocols when using the internet:

- Secure Sockets Layer (SSL)
- Transport Layer Security (TLS).

SECURE SOCKETS LAYER (SSL) is a type of protocol (a set of rules used by computers to communicate with each other across a network). This allows data to be sent and received securely over the internet.

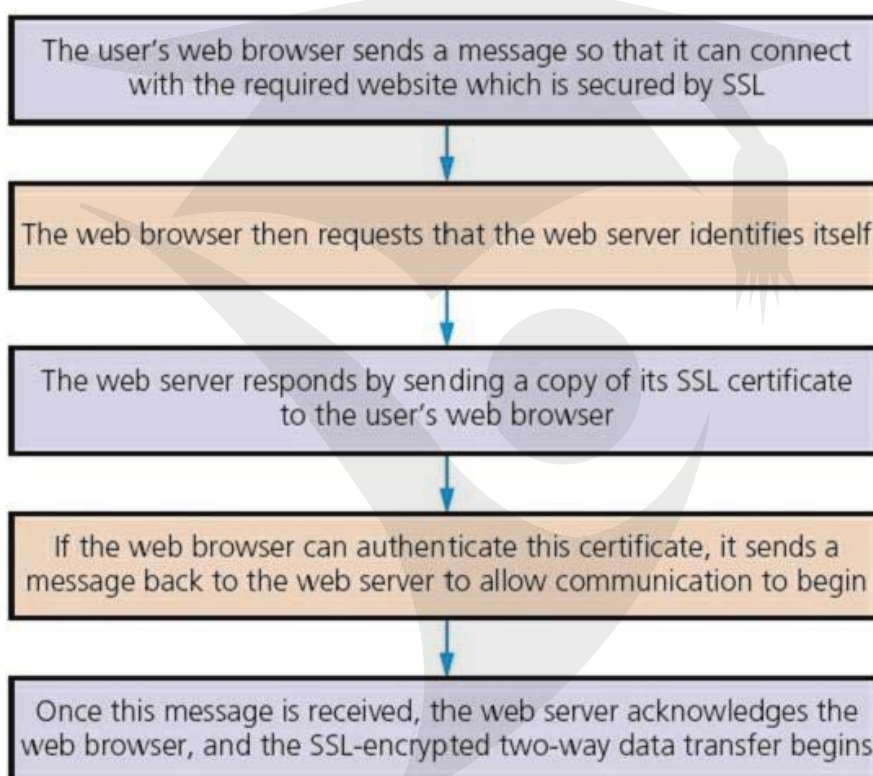
When a user logs onto a website, SSL encrypts the data – only the user's computer and the web server are able to make sense of what is being transmitted. A user will know if SSL is being applied when they see https or the small padlock in the status bar at the top of the screen. So what happens when a user wants to access a secure website and receive and send data to it?



TRANSPORT LAYER SECURITY (TLS) is similar to SSL but is a more recent security system. TLS is a form of protocol that ensures the security and privacy of data between devices and users when communicating over the internet. It is essentially designed to provide encryption, authentication and data integrity in a more effective way than its predecessor SSL.

When a website and client (user) communicate over the internet, TLS is designed to prevent a third party hacking into this communication causing problems with data security.

TLS is formed of two layers:

- Record protocol: this part of the communication can be used with or without encryption (it contains the data being transferred over the internet).
- handshake protocol: this permits the website and the client (user) to authenticate each other and to make use of encryption algorithms (a secure session between client and website is established). Only

the most recent web browsers support both SSL and TLS which is why the older SSL is still used in many cases. But what are the main differences between SSL and TLS since they both effectively do the same thing?

- It is possible to extend TLS by adding new authentication methods.
- TLS can make use of **SESSION CACHING** which improves the overall performance 158 compared to SSL.
- TLS separates the handshaking process from the record protocol (layer) which holds all the data.

Session caching

When opening a TLS session, it requires a lot of computer time (due mainly to the complex encryption keys being used). The use of session caching can avoid the need to utilise so much computer time for each connection. TLS can either establish a new session or attempt to resume an existing session; using the latter can considerably boost system performance.

Summer 2015 P12

(a) State what is meant by the term SSL.

.....

.....

.....[1]

(b) The following stages take place when a user wishes to access a secure website.

Put each stage in sequence by writing the numbers 1 to 6 in the column on the right. The first one has been done for you. [5]

Stage	Sequence number
the encrypted data is then shared securely between the web browser and the web server	
the web browser attempts to connect to a website which is secured by SSL	1
the web server sends the web browser a copy of its SSL certificate	
the web browser requests the web server to identify itself	
the web server will then send back some form of acknowledgement to allow the SSL encrypted session to begin	
the web browser checks whether the SSL certificate is trustworthy; if it is, then the web browser sends a message back to the web server	

Marking Scheme

(a) Any one from:

- Secure sockets layer – encrypts data being transmitted
- Use of https – use public and private keys

[1]

(b) 1 mark for each number in the correct order, next to the correct stage.

Stage	Sequence number
the encrypted data is then shared securely between the web browser and the web server	6
the web browser attempts to connect to a website which is secured by SSL	1
the web server sends the web browser a copy of its SSL certificate	3
the web browser requests the web server to identify itself	2
the web server will then send back some form of acknowledgement to allow the SSL encrypted session to begin	5
the web browser checks whether the SSL certificate is trustworthy; if it is, then the web browser sends a message back to the web server	4

Data Encryption

Encryption is the conversion of electronic data into another form, called cipher text, which cannot be easily understood by anyone except authorized parties.

The word encryption comes from the Greek word kryptos, meaning hidden or secret.

EMUFPHZLRFAXYUSDJKZLDRNSHGNFIVJ
 YQTQUXQBQVYUUVLLTREVJYQTMKYRDMFD
 VFPJUDEEHZWETZYV GWHK KQETGFGQJNCE
 GGWHKK?DQMCPEFQZDQMMIAGPFXHQRLG
 TIMVMZJANQLVKQEDAGDVFRPJUNGEUNA
 QZGZLECGYUXUEENJTBJLBQCRTBJDFHRR
 YIZETKZEMVDUEKSIJHKFWHKUWQLSZFTI
 HHHDDUVH?DWKBFUFPWNTDFIYCUQZERE
 EVLDKFEZMOQQJLTTUGSYQPFEUNLAVIDX
 FLGGTEZ?FKZBSFDQVGGGIPUFXXHHRKE
 FHQNTGPUAECNUVPDJMQCLQUMUNEDFQ
 ELZZVRRGKFFVOEEXBDMPNFGQXEZLGRE
 DNQFMPNZGLFLPMRJQYALMGNUPDXVKP
 DQUMEBEDMHDAFMJGZNUPLGEWJLLAETG
 ENDYAHR OHNLSRHEOCPTEOIBIDYSHNAIA
 CHTNREYULDSL LLLNOHSNOSMRWXMNE
 TPRNGATHNRARPE SLNNELEBLPIIACAE
 WMTWNDITEENRAHCTENEUDRETNHAEOE
 TFOLSEDTIWENHAEIOYTEYQHEENCTAYCR
 EIFTBRSPAMHHEWENATAMATEGEGYEEERLB
 TEEFOASFIOTUETUAETOARMAEERTNRTI
 BSEDDNIAAHTTMSTEWPPIEROAGRIEWFEB
 AECTDDHILCEIHSITEGOEAOSDDRYDLORIT
 RKLMLHAGTDHARDPNEOHMGFMFEUHE
 ECDMRIPFEIMEHNLSSTTRTVDOHW?OBKR
 UOXOGHULBSOLIFBBWFLRVQQPRNGKSSO
 TWTQJSJQSSEKZZWATJKLUDIAWINFBNYP
 VTTMZFPKWGDKZXTJCDIGKUHUAUEKCAR

KryptonRevisited.com

Caesar Cipher (Encryption)

The earliest known and simplest ciphers. The method is named after **Julius Caesar**.

It is a type of substitution cipher in which each letter in the plaintext is 'shifted' a certain number of places down the alphabet.

For example, with a shift of -4, A would be replaced by X, D would become 4, and so on.

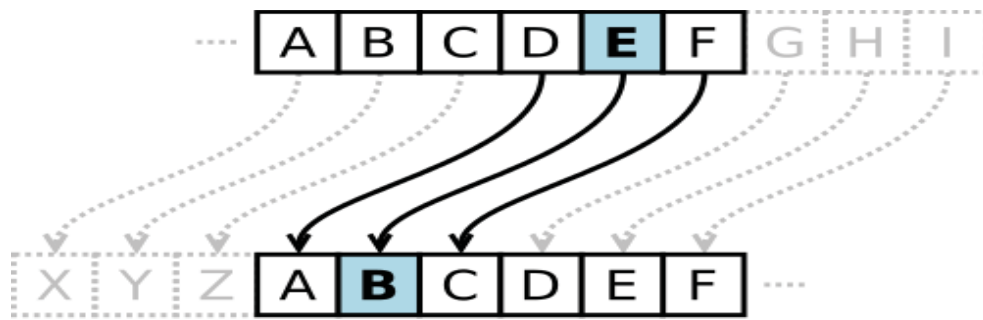

Encryption makes the data meaningless unless the recipient has the necessary decryption tools.

There are two types of encryption:

SYMMETRIC ENCRYPTION is a method of encryption in which one key is required to encrypt and decrypt the data.

ASYMMETRIC ENCRYPTION (also known as Public Key Encryption) is a method of encryption in which one key (public key) is required to encrypt and other key (private key) to decrypt the data.

Symmetric Encryption

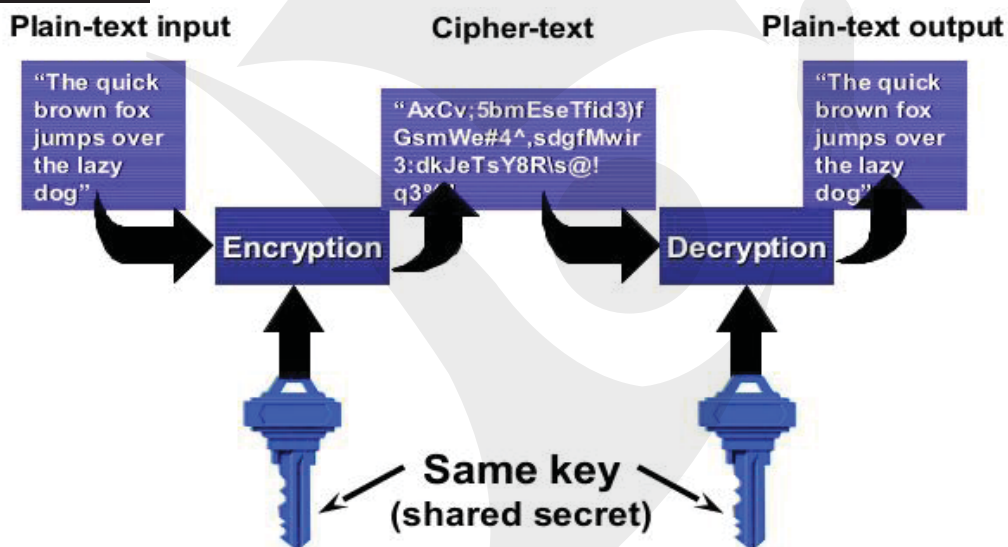

KEY Distribution Problem:

In symmetric key encryption the sender has to supply the encryption key to the recipient. But this key could be hacked, which puts the security of the encrypted message at risk. This problem is known as key distribution problem.

ASYMMETRIC (PUBLIC KEY) ENCRYPTION

Public-key encryption is a cryptographic system that uses two keys

-- a *public key* known to everyone

-- and a *private* or *secret key* known only to the owner of the key.

If a message is encrypted by Public key it can only be decrypted by associated Private key.

If a message is encrypted by private key it can only be decrypted by associated public key.

Example 1: When Bob wants to send a secure message to Alice, he uses Alice's public key to encrypt the message. Alice then uses her private key to decrypt it. (To make not-understandable for others)

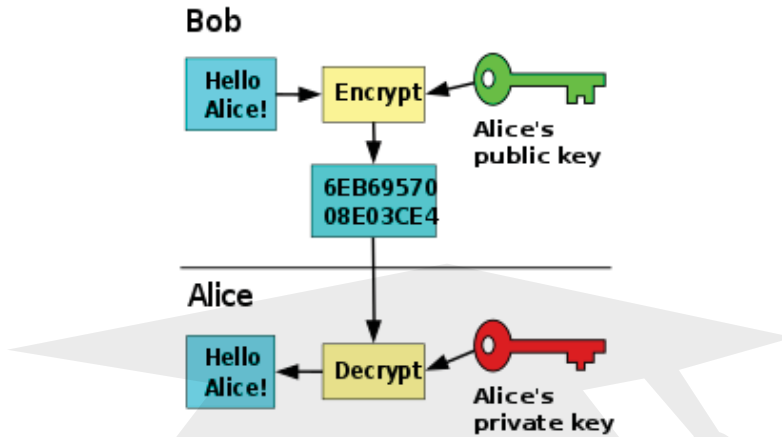

Example 2: When Alice wants to ensure that the message is sent by her (to verify the sender and message is not altered, not to make message secure (not-understandable by others)), she encrypts her message using her own private key.

Then the message is transmitted to Bob.

Bob decrypts the message using Alice's public key.

The decryption of message by Alice's public key confirms that this is Alice's message, and is without any alteration.

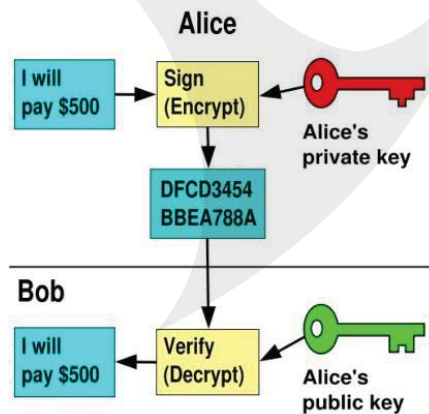

Digital certificates

Digital certificates are used in Internet communications. A Certificate Authority (CA) is responsible for issuing digital certificates.

contains Name of certification authority, Public key of company and Expiry date.

The method of issuing a digital certificate is as follows:

1. A user starts an application for a digital certificate using their computer. On this computer a key pair is generated. This key pair consists of a public key and an associated private key.
2. The user submits the application to the CA. The generated public key and other application data are sent.
3. The key and data are encrypted using the CA's public before sending to CA.
4. The CA creates a digital document containing all necessary data items and signs it using the CA's private key.
5. The CA sends the digital certificate to the individual.

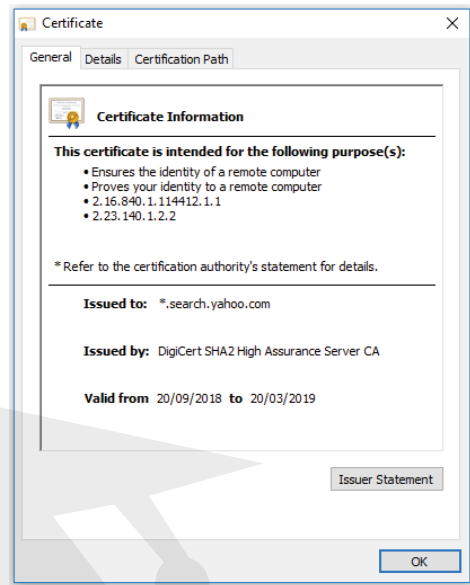

It

key

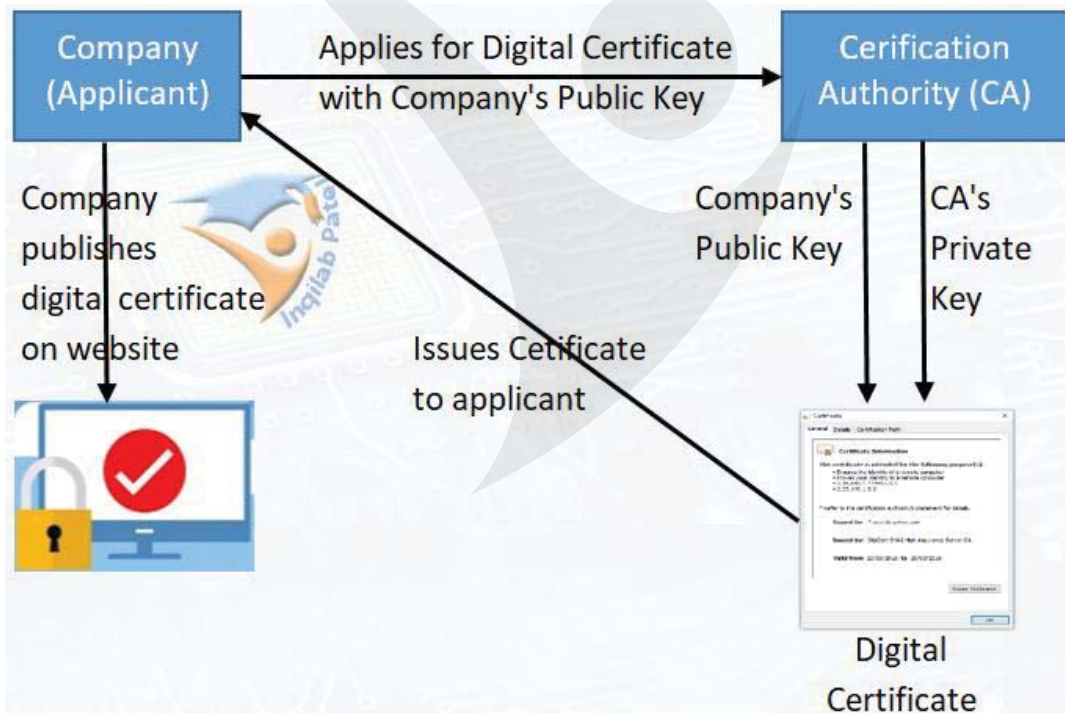

HASHING ALGORITHM

The hashing algorithm takes a message or a key and translates it into a string of characters usually shown in hexadecimal essentially makes the message or key almost impossible to read 'meaningless' text. This is also known as message digest.



Authentication

Authentication means the receiver is certain who sent the cipher text.

For authentication passwords, digital certificates and digital signatures are used/

Digital signature

A digital signature is a mathematical scheme for verifying the authenticity of digital messages or documents. A valid digital signature gives a recipient reason to believe that the message was created by a known sender (authentication), that the sender cannot deny having sent the message (non-repudiation), and that the message was not altered in transit.

How digital signature works

- Sender applies HASH algorithm on the message.
- Message digest is created.
- Sender encrypts the message digest using his own private key. This encrypted message digest is called Digital Signature.
- Plain text along with digital signature is sent to recipient.

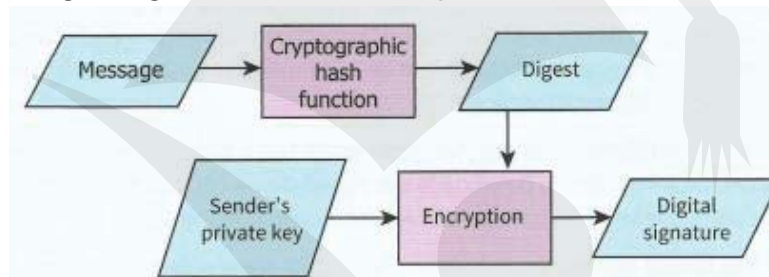

Receiver receives both plain message and digital signature

Receiver applies the same HASH algorithm on message and obtains message digest

Receiver then encrypts the receiving digital signature using sender's public key to obtain sender's message digest.

Receiver compares his own generated message digest with the sender's message digest.

If both matches then message is sent from the intended source.

Digital signature is used to identify the sender.

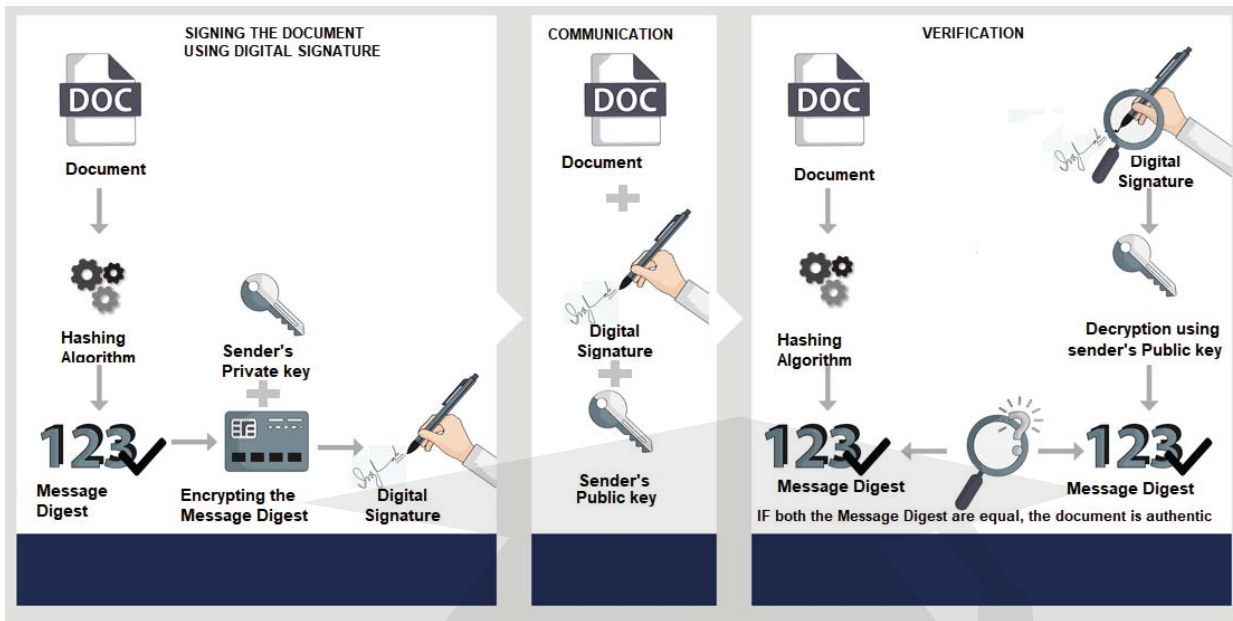

DENIAL OF SERVICE ATTACKS

A denial of service attack (DoS) is an attempt at preventing users from accessing part of a network, notably an internet server.

The attacker may be able to prevent a user from:

- ❖ accessing their emails
- ❖ accessing websites/web pages
- ❖ accessing online services (such as banking).

One method of attack is to flood the network with useless traffic.

When a user types in or clicks on a URL of a website (using their web browser), a request is sent to the internet server which contains the website or web page.

Obviously, the server can only handle a finite number of requests. So if it becomes overloaded by an attacker sending out thousands of requests, it won't be able to service the user's legitimate request. This is effectively a denial of service.



Specimen Paper 2015

Q1) In a simple symmetric encryption system, each letter of the alphabet is substituted with another.

The plain text message:

The Quick brown Fox jumps over a lazy dog.

becomes the cypher text message:

Zag towns jumpy Dmh coilv mwgu f bfke rmq

(a) (i) Convert these words to cypher text.

Computer Science

..... [2]

(ii) Decode this cypher text message.

NV pwza Wytwbj

..... [2]

(b) Both the person who sends the message and the person who receives it need to know what the substitution key is, and they need to keep this secret. A copy of the substitution key has been sent using SSL transmission.

Explain why this keeps the copy of the key secret during transmission.

..... [2]

(d) A user downloads software from the Internet.

(i) State what should be part of the download to provide proof that the software is authentic?

.....[1]

(ii) Describe the process for ensuring that the software is both authentic and has not been altered.

.....
.....
.....
.....
.....
.....
.....
.....
.....
.....
.....
..... [4]

(d) (i)	digital signature
(ii)	<ul style="list-style-type: none"> • software is put through hashing algorithm • hash total is encrypted with private key (digital signature) • software + encrypted hash / digital signature are sent • receiver is in possession of sender's public key • the received hash total / digital signature is decrypted with public key (SH) • the receiver hashes received software (RH) • If SH matches RH then software is authentic and has not been altered

Q 3) Digital certificates are used in Internet communications. A Certificate Authority (CA) is responsible for issuing digital certificates.

(a) Name **three** data items present in a digital certificate.

- 1
- 2
- 3[3]

(b) The method of issuing a digital certificate is as follows:

1 A user starts an application for a digital certificate using their computer. On this computer a key pair is generated. This key pair consists of a public key and an associated private key.

2 The user submits the application to the CA. The generated(i)key and other application data are sent. The key and data are encrypted using the CA's(ii)key.

3 The CA creates a digital document containing all necessary data items and signs it using the CA's(iii)key.

4 The CA sends the digital certificate to the individual. In the above method there are three missing words. Each missing word is either 'public' or 'private'. State the correct word. Justify your choice.

(i)

Justification
.....[2]

(ii)

Justification
.....[2]

(iii)

Justification
.....[2]

(c) Alexa sends an email to Beena.

Alexa's email program:

- produces a message digest (hash)
- uses Alexa's private key to encrypt the message digest
- adds the encrypted message digest to the plain text of her message
- encrypts the whole message with Beena's public key
- sends the encrypted message with a copy of Alexa's digital certificate

Beena's email program decrypts the encrypted message using her private key.

(i) State the name given to the encrypted message digest.

.....[1]

(ii) Explain how Beena can be sure that she has received a message that is authentic (not corrupted or tampered with) and that it came from Alexa.

.....

[2]

(iii) Name **two** uses where encrypted message digests are advisable.

1
 2[2]

(a)	Examples: Serial number Certificate Authority that issued certificate CA digital signature Name of company/organisation/individual/subject/owner owning Certificate 'Subject' public key Period during which Certificate is valid // some relevant date
(b) (i)	Public The individual keeps their private key private // the public key can be known by others (the public)
(ii)	Public The individual does not know the private key of the CA // the individual only knows the public key of the CA // only the CA can decrypt the packaged information

(iii)	Private 'Only' the CA's public key will allow decryption of the Certificate // proving the certificate was issued by the CA
(c) (i)	Digital signature
(ii)	Alexa's digital certificate (Includes) Alexa's public key Used to hash message received // produce message digest Generated hash compared to digital signature
(iii)	Examples: Financial transaction Legal document Software distribution

Candidate Example Response

Example candidate response – high

1 (a) Four statements about cookies are shown in the table below.

Study each statement.

Tick (✓) to show whether the statement is true or false.

Statement	True	False
they are a form of spyware		✓
they are used only in advertising		✓
they are used to track browser use	✓	
they act in the same way as a virus		✓

[4]

(b) Five descriptions and five security issues are shown below.

Draw a line to connect each description to the correct security issue.

Description	Security Issue
malicious code installed on the hard drive of a user's computer or on the web server; this code will re-direct user to a fake web site without their consent	hacking
software that gathers information by monitoring key presses on a user's computer and relays the information back to the person who sent the software	pharming
program or code that replicates itself and is designed to amend, delete or copy data and files on a user's computer without their consent	phishing
the act of gaining illegal access to a computer system without the owner's consent	spyware
creator of code sends out a legitimate-looking email in the hope of gathering personal and financial data; it requires the recipient to follow a link in the email or open an attachment	virus

[4]

Example candidate response – middle

1 (a) Four statements about cookies are shown in the table below.

Study each statement.

Tick (✓) to show whether the statement is true or false.

Statement	True	False
they are a form of spyware		X
they are used only in advertising	✓	
they are used to track browser use	✓	
they act in the same way as a virus		X

[4]

(b) Five descriptions and five security issues are shown below.

Draw a line to connect each description to the correct security issue.

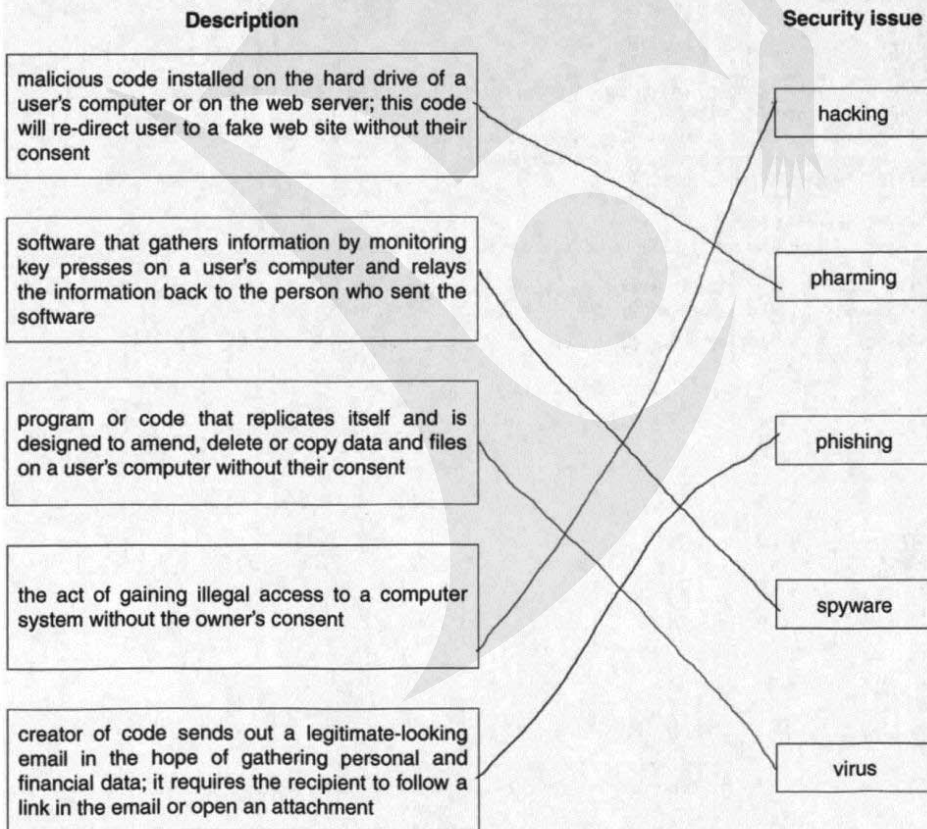

[4]

Example candidate response – low

1 (a) Four statements about cookies are shown in the table below.

Study each statement.

Tick (✓) to show whether the statement is true or false.

Statement	True	False
they are a form of spyware		✓
they are used only in advertising	✓	
they are used to track browser use	✓	
they act in the same way as a virus	✓	

[4]

(b) Five descriptions and five security issues are shown below.

Draw a line to connect each description to the correct security issue.

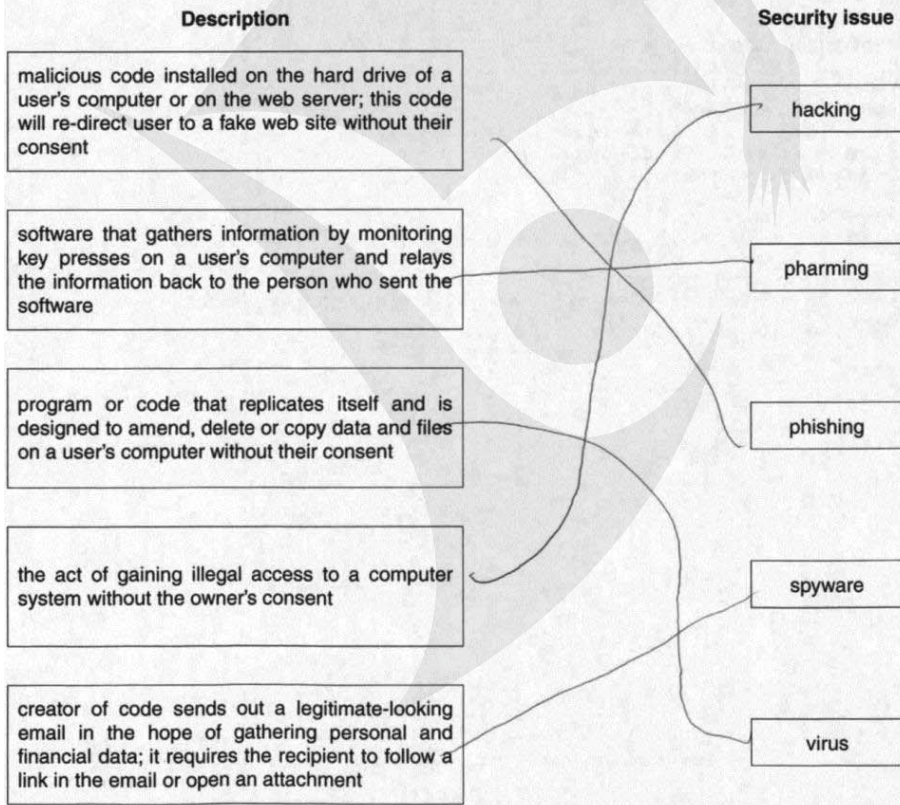

[4]

Example candidate response – high

4 (a) State what is meant by the term SSL.

Secure Socket Layer is a program which helps users be able to use secure applications on the internet and be able to browse safely/securely. [1]

(b) The following stages take place when a user wishes to access a secure website.

Put each stage in sequence by writing the numbers 1 to 6 in the column on the right. The first one has been done for you.

Stage	Sequence number
the encrypted data is then shared securely between the web browser and the web server	6
the web browser attempts to connect to a website which is secured by SSL	1
the web server sends the web browser a copy of its SSL certificate	3
the web browser requests the web server to identify itself	2
the web server will then send back some form of acknowledgement to allow the SSL encrypted session to begin	5
the web browser checks whether the SSL certificate is trustworthy; if it is, then the web browser sends a message back to the web server	4

[5]

Examiner comment – high

In part (a) this candidate correctly states that SSL is secure sockets layer.

In part (b) they manage to get the correct sequence of events when a person uses a secure website.

Marks awarded for (a) = 1 out of 1

Marks awarded for (b) = 5 out of 5

Total mark awarded = 6 out of 6

Example candidate response – middle

4 (a) State what is meant by the term SSL.

Secure Socket Layer.
 Which advise the user that the web pages
 are secure. It can be seen in the ~~URL~~ URL. [1]

(b) The following stages take place when a user wishes to access a secure website.

Put each stage in sequence by writing the numbers 1 to 6 in the column on the right. The first one has been done for you.

Stage	Sequence number
the encrypted data is then shared securely between the web browser and the web server	6
the web browser attempts to connect to a website which is secured by SSL	1
the web server sends the web browser a copy of its SSL certificate	3
the web browser requests the web server to identify itself	4
the web server will then send back some form of acknowledgement to allow the SSL encrypted session to begin	5
the web browser checks whether the SSL certificate is trustworthy; if it is, then the web browser sends a message back to the web server	2

[5]

Examiner comment – middle

In part (a) this candidate correctly states that SSL is secure sockets layer.

In part (b) they mix up stages 2 and 4 in the sequence. The browser needs the server to identify itself before it can carry out any further stages.

Marks awarded for 4(a) = 1 out of 1

Marks awarded for 4(b) = 3 out of 5

Total mark awarded = 4 out of 6

Example candidate response – low

4 (a) State what is meant by the term SSL.

Server Security Log

[1]

(b) The following stages take place when a user wishes to access a secure website.

Put each stage in sequence by writing the numbers 1 to 6 in the column on the right. The first one has been done for you.

Stage	Sequence number
the encrypted data is then shared securely between the web browser and the web server	4
the web browser attempts to connect to a website which is secured by SSL	1
the web server sends the web browser a copy of its SSL certificate	3
the web browser requests the web server to identify itself	2
the web server will then send back some form of acknowledgement to allow the SSL encrypted session to begin	6
the web browser checks whether the SSL certificate is trustworthy; if it is, then the web browser sends a message back to the web server	5

[5]

Examiner comment – low

In part (a), the candidate gives an incorrect response from the definition of SSL. It was a good attempt, but not correct.

In part (b), the candidate starts the sequence correctly but then gets the last three stages in the incorrect order. The web browser needs to check the certificate is trustworthy before it will share the encrypted data.

Marks awarded for 4(a) = 0 out of 1

Marks awarded for 4(b) = 2 out of 5

Total mark awarded = 2 out of 6

Example Candidate Response – high

Examiner Comments

5 A music company wants to send a new music file to many radio stations. It will send the music file the day before the release date so that the radio stations can store the file ready for release.

The music company does not want the radio stations to be able to open the music file until 09:00 on the release date.

Identify **two** security measures **and** describe how each measure can be used to make sure the music file cannot be opened until the release date.

Security measure 1 password.....

Description The password will be sent out at 9AM 1

..... so people can't open it before. A password uses

..... a combination of letters and numbers.....

Security measure 2 encryption.....

Description Scramble up the data in the music.....

..... using an encryption algorithm. The music company will

send the encryption key at 9AM.

[4]

1 It would be beneficial for candidates to state that this was 9am on the release date.

Total mark awarded =
4 out of 4

How the candidate could have improved their answer

The candidate gave just enough of a reference to releasing the password and encryption key on the release data as they stated they could have been released at 9am. It would have been beneficial for the candidate to have stated that this was 9am on the release date.

Example Candidate Response – middle

Examiner Comments

5 A music company wants to send a new music file to many radio stations. It will send the music file the day before the release date so that the radio stations can store the file ready for release.

The music company does not want the radio stations to be able to open the music file until 09:00 on the release date.

Identify **two** security measures **and** describe how each measure can be used to make sure the music file cannot be opened until the release date.

Security measure 1 The file can be secured by a password

Description: If the file is secured by a password

other people won't be able to access it until the

password can be given out sometime before the release 1

Security measure 2 The file can be encrypted and then

Description The encrypted file could be de-

rypted few moments before the release 2

[4]

1 This timescale is too vague. The system will only work if the password is given out on the release date.

2 The candidate doesn't state how the file will be decrypted.

Total mark awarded =
2 out of 4

How the candidate could have improved their answer

The candidate hasn't been specific enough in referring to when the password and decryption key could be given to the company. They stated that it could be some time before the release date, but the system would not work unless the password was given out on the release date.

Example Candidate Response – low	Examiner Comments
<p>5 A music company wants to send a new music file to many radio stations. It will send the music file the day before the release date so that the radio stations can store the file ready for release.</p> <p>The music company does not want the radio stations to be able to open the music file until 09:00 on the release date.</p> <p>Identify two security measures and describe how each measure can be used to make sure the music file cannot be opened until the release date.</p> <p>Security measure 1 <u>Pass code / Fingerprint scanner</u></p> <p>Description <u>If some has to open he or she use to scan their finger or enter code if it would be wrong an alarm would be start sounding</u></p> <p>Security measure 2 <u>Timer</u></p> <p>Description <u>Without the given time it would not be open or if some one tries to open it would give big info his or her computer</u></p> <p style="text-align: right;">[4]</p>	<p>1 The candidate is awarded a mark for passcode in reference to password.</p> <p>2 The system described is not a viable system in the given scenario.</p> <p>Total mark awarded = 1 out of 4</p>

How the candidate could have improved their answer

- The candidate was given the benefit of the doubt for the reference to the use of a passcode in place of a password. The remainder of the answer had no reference to sending out the password at the release date.
- The second system offered by the candidate was not a system that would be viable in this scenario.

Common mistakes candidates made in this question

Many candidates gave viable systems, such as password and encryption. Some candidates were not specific in how that system would work and when the password or encryption key would be sent to the company.

Example Candidate Response – high	Examiner Comments																		
<p>(b) Priya uses cookies in her website.</p> <p>Five statements are given about cookies.</p> <p>Tick (✓) to show if the statement is True or False.</p> <table border="1"> <thead> <tr> <th>Statement</th> <th>True (✓)</th> <th>False (✓)</th> </tr> </thead> <tbody> <tr> <td>Cookies can be used to store a customer's credit card details</td> <td style="text-align: center;">✓</td> <td></td> </tr> <tr> <td>Cookies can be used to track the items a customer has viewed on a website</td> <td style="text-align: center;">✓</td> <td></td> </tr> <tr> <td>Cookies will corrupt the data on a customer's computer</td> <td></td> <td style="text-align: center;">✓</td> </tr> <tr> <td>Cookies are downloaded onto a customer's computer</td> <td style="text-align: center;">✓</td> <td></td> </tr> <tr> <td>Cookies can be deleted from a customer's computer</td> <td style="text-align: center;">✓</td> <td></td> </tr> </tbody> </table> <p style="text-align: right;">[5]</p>	Statement	True (✓)	False (✓)	Cookies can be used to store a customer's credit card details	✓		Cookies can be used to track the items a customer has viewed on a website	✓		Cookies will corrupt the data on a customer's computer		✓	Cookies are downloaded onto a customer's computer	✓		Cookies can be deleted from a customer's computer	✓		<p>1 The candidate provides five correct ticks.</p> <p>Total mark awarded = 5 out of 5</p>
Statement	True (✓)	False (✓)																	
Cookies can be used to store a customer's credit card details	✓																		
Cookies can be used to track the items a customer has viewed on a website	✓																		
Cookies will corrupt the data on a customer's computer		✓																	
Cookies are downloaded onto a customer's computer	✓																		
Cookies can be deleted from a customer's computer	✓																		

How the candidate could have improved their answer

The candidate provided a model answer that could not be improved.

Example Candidate Response – middle

Examiner Comments

(b) Priya uses cookies in her website.

Five statements are given about cookies.

Tick (✓) to show if the statement is True or False.

Statement	True (✓)	False (✓)
Cookies can be used to store a customer's credit card details	✓	
Cookies can be used to track the items a customer has viewed on a website	✓	
Cookies will corrupt the data on a customer's computer		✓
Cookies are downloaded onto a customer's computer		✓
Cookies can be deleted from a customer's computer	✓	

[5]

1 The candidate provides an incorrect response for statement four.

Total mark awarded = 4 out of 5

How the candidate could have improved their answer

The candidate showed some understanding of the fact that cookies could be deleted from a computer. They needed to extend that understanding to have known that the cookies were downloaded onto the computer too, so that they could be deleted.

Example Candidate Response – low

Examiner Comments

(b) Priya uses cookies in her website.

Five statements are given about cookies.

Tick (✓) to show if the statement is True or False.

Statement	True (✓)	False (✓)
Cookies can be used to store a customer's credit card details	✓	
Cookies can be used to track the items a customer has viewed on a website	✓	
Cookies will corrupt the data on a customer's computer		✓
Cookies are downloaded onto a customer's computer		✓
Cookies can be deleted from a customer's computer		✓

[5]

1 The candidate shows limited understanding of the fact that cookies can be downloaded on to, and deleted from, a user's computer.

Total mark awarded = 3 out of 5

How the candidate could have improved their answer

The candidate didn't understand that cookies could be downloaded to a user's computer and therefore deleted from it as well.

Common mistakes candidates made in this question

Candidates appeared to understand how cookies could be used to store details and track browsing habits. It would have been beneficial for candidates to also have known how cookies were stored and whether they could be deleted.

Example Candidate Response – high

Examiner Comments

(e) Priya is concerned about a denial of service attack (DoS) occurring on her webserver.

(i) Explain what is meant by a denial of service attack.

When a device (hacker) sends a large amount of requests to a webserver at one time, overloading the web server and potentially leading to the server crashing or being extremely slow for other users trying to access the web server.

[4]

1 The first mark is awarded for the large number of requests sent.

2 The second mark is awarded for stating the requests are all sent at the same time.

3 The third mark is awarded for stating the server crashes. This is an acceptable way of stating it will timeout.

4 If the candidate is more specific and says that this denies people access, then a fourth mark could be awarded.

Total mark awarded =
3 out of 4

How the candidate could have improved their answer

The candidate stated that the DoS would make the server extremely slow for others. If they had been more specific and said that this would have denied people access, then a fourth mark could have been awarded.

Example Candidate Response – middle

Examiner Comments

(e) Priya is concerned about a denial of service attack (DoS) occurring on her webserver.

(i) Explain what is meant by a denial of service attack.

It's when a user cannot access a part of the network, possibly an internet server. This can prevent the user from accessing their e-mails or online services like banking. The attacker can send millions of requests which will clog up the process, this prevents the website from serving the user's legitimate requests. The ISP provides every webserver a specific data quota and can only handle a finite number of requests. An attacker can prevent other users from accessing the web site. [4]

- 1 The candidate needs to be more specific in their reference to the location of the attack. An Internet server is too vague and it needs to be a web server.
- 2 A mark is awarded for naming specific services that the user may be prevented from accessing.
- 3 A mark is awarded for reference to a high number of requests sent.
- 4 This repeats a mark of one gained earlier.
- 5 The candidate almost gains a mark here, as they state the server can only handle a finite number of requests, but they are missing the detail that this is why the server will struggle to handle the number of requests.

**Total mark awarded =
2 out of 4**

How the candidate could have improved their answer

- The reference to the location of the attack being on an Internet server was too vague; it needed to be a web server. The candidate needed to be more specific in their reference to the location of the attack.
- In their last sentence, had the candidate expanded this to say that this was why the server would struggle with the number of requests, another mark could have been awarded.

Example Candidate Response – low

Examiner Comments

(e) Priya is concerned about a denial of service attack (DoS) occurring on her webserver.

(i) Explain what is meant by a denial of service attack.

It is occurred when someone tries to
hack your page or tries to produce virus
in the page so that it could not be worked
so with the help of DoS when ever it
~~is~~ indicates that someone is hacking.
it gave the sign to the admin of page
to protect it or it is danger on his
page. ¹ [4]

¹ The candidate shows little understanding of a DoS attack. The candidate understands it to involve hacking and the use of viruses.

Total mark awarded =
0 out of 4

How the candidate could have improved their answer

The candidate understood a DoS attack to involve hacking and viruses. It would have been beneficial for the candidate to have understood that there were other Internet risks not involved in this process.

Common mistakes candidates made in this question

This was a technical process that candidates had been asked to describe, so accuracy was important. A common error made by candidates was not providing enough notion that it was a high number of requests that were sent. Some candidates stated several requests or some requests.

Past Papers

Q 1) Summer 2015 P11

4 Choose **six** correct terms from the following list to complete the spaces in the paragraphs below:

- encryption
- HTML tags/text
- proxy server
- file name
- IP address
- SSL certificate
- firewall
- protocol
- web server name

A user enters a URL. The web browser breaks up the URL into **three** components:

- 1
- 2
- 3

The web server returns the selected web page.

The web browser reads the from the selected page and shows the correctly formatted page on the user's screen.

A is used between the user's computer and the network to examine the data traffic to make sure it meets certain criteria.

To speed up the access to the web pages next time, a is used between the computer and web server; this device uses a cache to store the website home page after it has been accessed for the first time. [6]

Examiner's Comments on Question 4

The full range of marks were awarded to candidates for this question. It was clear some candidates knew the process and gained full marks, but most candidates achieved two or three marks.

6 (a) Viruses, pharming and phishing are all examples of potential Internet security issues. Explain what is meant by each of these **three** terms.

Virus:

Pharming:

Phishing:

.....[6]

(b) An online bank requires a client to supply an 8-digit code each time they wish to access their account on the bank's website.

Rather than ask the client to use a keyboard, they are requested to use an on-screen keypad (shown on the right) to input the 8-digit code.

The position of the digits on the keypad can change each time the website is visited.

The client uses a mouse or touch screen to select each of the 8 digits.

(i) Explain why the bank has chosen to use this method of entering the 8 digits.

.....

..... [2]

2	5	1
6	8	3
9	0	4
	7	

(ii) Name and describe **another** measure that the bank could introduce to improve the security of their website.

Name:
 Description:

 [2]

Q 3) Winter 2015 P12

1 There are a number of security risks associated with using the Internet.

Name **three** of these risks. For each, state why it is a risk and describe how the risk can be minimised.

Security risk 1:
 Why it is a risk:

 How to minimize the risk:.....

Security risk 2:
 Why it is a risk:

 How to minimize the risk:

Security risk 3:
 Why it is a risk:

 How to minimize the risk:

..... [9]

Q 4) Winter 2015 P13

4 (b) The four statements below refer to firewalls and proxy servers. Study each statement.

Tick (9) the appropriate column(s) to indicate whether the statement refers to a firewall and/or a proxy server. [4]

Statement	Firewall	Proxy server
Speeds up access of information from a web server by using a cache		
Filters all Internet traffic coming into and out from a user's computer, intranet or private network		
Helps to prevent malware, including viruses, from entering a user's computer		
Keeps a list of undesirable websites and IP addresses		

(c) Explain **three** ways of preventing **accidental** loss or corruption of data.

1

(ii) Give a reason why the system asks for four characters chosen at random.

.....[1]

(b) Biometrics is an additional form of security.

Give two examples of biometrics.

1
 2 [2]

10 Six security issues and six descriptions are shown below.

Draw a line to link each security issue to its correct description.[5]

Term	Description
Pharming	illegal access to a computer system without the owner' s consent or knowledge
Phishing	software that gathers information by monitoring key presses on a user' s keyboard; the data is sent back to the originator of the software
Viruses	malicious code installed on the hard drive of a user' s computer or on a web server; this code will re-direct the user to a fake website without the user' s knowledge
Hacking	creator of code sends out a legitimate-looking email in the hope of gathering personal and financial information from the recipient; it requires the user to click on the link in the email or attachment
Spyware	a message given to a web browser by a web server; it is stored in a text file; the message is then sent back to the server each time the browser requests a page from the server
Cookies	program or code that replicates itself; designed to amend, delete or copy data or files on a user' s computer; often causes the computer to crash or run slowly

Q 8) Winter 2016 P12

5 A computer uses an 8-bit register.
The 8-bit register contains binary integers.

(a) Write the denary (base 10) value represented by:

128	64	32	16	8	4	2	1
0	1	1	1	0	0	0	0

.....[1]
(b) All the bits in the register are shifted **one** place to the **right** as shown below.

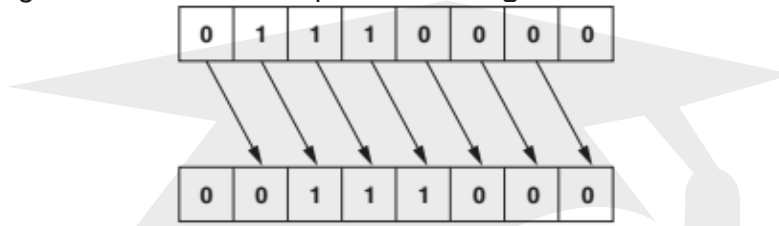

Write the denary number that is represented after this shift.
.....[1]

(c) State the effect the shift to the right had on the original denary number from **part (a)**.
.....[1]

(d) The original number in **part (a)** is shifted **three** places to the **right**.

(i) Show the new binary number: [1]

--	--	--	--	--	--	--	--

(ii) Write the equivalent denary number.
.....[1]

(e) Describe the problems that could be caused if the original binary number in **part (a)** is shifted **five** places to the **right**.

.....

.....

.....

.....

.....[2]

9 (a) Explain what is meant by a denial of service attack.

.....

.....

.....

.....[2]

(b) Name and describe **two other** potential security threats when using the Internet.

Security threat 1

Description

.....

.....

Security threat 2
 Description
 [4]

Q 9) Winter 2016 P11& 13

2 Name each of the potential security issues described in the **five** statements below: [5]

Statement	Security issue
The act of gaining unauthorised access to a computer system
Program code that can replicate itself with the intention of deleting or corrupting files stored in a computer
A small file sent by a web server to a web browser; every time the user visits the website, data about user preferences is collected
The act of illegally changing the source code of a program so that it can be exploited for another use
Malicious code installed on a user's hard drive or a web server which redirects the user to a fake website without their knowledge

Q 10) March 2017 India

4 A simple symmetric encryption system is used to encrypt messages. Each letter of the alphabet is substituted by another letter.

Plain text

a	b	c	d	e	f	g	h	i	j	k	l	m	n	o	p	q	r	s	t	u	v	w	x	y	z
---	---	---	---	---	---	---	---	---	---	---	---	---	---	---	---	---	---	---	---	---	---	---	---	---	---

Cypher text

v	p	n	a	q	b	r	u	z	s	c	o	y	k	w	f	x	i	e	m	d	j	t	l	h	g
---	---	---	---	---	---	---	---	---	---	---	---	---	---	---	---	---	---	---	---	---	---	---	---	---	---

(a) Convert the following plain text to cypher text.

Plain text: **data security**

Cypher text: [2]

Q 11) Summer 2017 P11) 7 Six security terms and **six** statements are listed below.
Draw a line to match the security term with the most appropriate statement. [5]

Security term	Statement
Encryption	Provides a secure connection between web browsers and websites allowing secure transmission of private data.
Secure Socket Layer (SSL)	Computer that acts as an intermediary between a web browser and the Internet.
Pharming	Legitimate-looking email is sent in the hope of gathering personal information; it requires the user to click on a link in the email.
Phishing	Uses rules and criteria, set by the user, to help protect a network or system from unauthorised access.
Firewall	Malicious code installed on the hard drive of a user's computer; this code will redirect the user to a fake website without the user's knowledge.
Proxy server	Scrambles data for secure transmission.

Q 12) Summer 2017 P12

8 A company has a number of offices around the world.

(a) Data is transmitted between the offices over the Internet. In order to keep the data safe the company is using Secure Socket Layer (SSL) protocol and a firewall at each office.

Explain how SSL protocol and a firewall will keep the company's data safe.

SSL protocol
.....
.....
Firewall
.....
..... [4]

(b) A company stores personal details of its customers on a computer system behind a firewall. Explain, with reasons, what else the company should do to keep this data safe.

.....
.....
.....
.....
.....
.....
.....
.....
.....
.....
.....
..... [6]

Q 13) Winter 2017 P12

5 Raj is using the Internet to do some online shopping. He visits a website that tells him that it uses cookies.

(a) Explain what is meant by the term **cookies**.

Method 1
.....
.....
.....
.....
.....
..... [4]

(b) Give **two** examples of the use of cookies.

Example 1

Example 2 [2]

10 (a) Describe what is meant by Transport Layer Security (TLS).

..... [3]

(b) Name **three** different applications of TLS.

1 [3]
2
3

Q 14) Winter 2017 P13

7 Six statements about firewalls are shown.

Tick (✓) to show whether each statement is true or false. [6]

Statement	True (✓)	False (✓)
Firewalls can monitor incoming and outgoing traffic.		
Firewalls operate by checking traffic against a set of rules.		
Firewalls cannot block access to a certain website.		
Firewalls can be software and hardware.		
Firewalls can act as intermediary servers.		
Firewalls can block unauthorised traffic.		

(b) The Secure Socket Layer (SSL) protocol can be used to securely transmit data in online banking. State three other different applications that use SSL.

- Application 1
- Application 2
- Application 3[3]

(c) Online banking is increasing in popularity.

Online banking can be a risk as it can raise a number of security issues. SSL can be used as a security method to make online banking safer.

Identify and describe three other security methods that could be used to make online banking safer.

- Security method 1
-
-
-
- Security method 2
-
-
-
- Security method 3
-
-
-
- [6]

Q 15) March 2018 P12 (India) 2 David has installed anti-virus software on his computer.

(a) State **three** tasks carried out by anti-virus software. [3]

- Task 1
-
- Task 2
-
- Task 3
-

Q 17) Summer 2018 P12

12 (a) Selma has some important personal information that she needs to email to her employer. She wants to make sure that if the personal information is intercepted, it cannot be understood.

(i) State how Selma could email her personal data more securely.

..... [1]

(ii) Describe how your chosen solution works.

.....
.....
.....
.....
.....
.....
.....
.....
.....
.....
.....
.....
.....
.....
..... [5]

Q 19) Winter 2018 P13) 6 Sarah stores data electronically. Describe three methods that she could use to avoid loss of stored data.

Method 1

Method 2

Method 3

..... [6]

(b) The art gallery also uses a firewall. **Six** statements are given about firewalls.

Tick (✓) to show if the statement is **True** or **False**.

[6]

Statement	True (✓)	False (✓)
Firewalls are only available as hardware devices		
Firewalls allow a user to set rules for network traffic		
Firewalls will automatically stop all malicious traffic		
Firewalls only examine traffic entering a network		
Firewalls encrypt all data that is transmitted around a network		
Firewalls can be used to block access to certain websites		

(c) The art gallery is concerned about computer ethics relating to its website.

Explain what is meant by computer ethics **and** why the art gallery is concerned about computer ethics.

.....

.....

.....

.....

.....

.....

.....

..... [4]

Q 22) Summer 2019 P12

6 Priya creates a website to sell her old comic books and superhero figures.

(b) Priya uses cookies in her website. **Five** statements are given about cookies.

Tick (✓) to show if the statement is **True** or **False**. [5]

Statement	True (✓)	False (✓)
Cookies can be used to store a customer's credit card details		
Cookies can be used to track the items a customer has viewed on a website		
Cookies will corrupt the data on a customer's computer		
Cookies are downloaded onto a customer's computer		
Cookies can be deleted from a customer's computer		

(e) Priya is concerned about a denial of service attack (DoS) occurring on her web server.

(i) Explain what is meant by a denial of service attack.

.....

.....

.....

.....

.....

.....

.....

.....

[4]

(ii) Give **one** security device that can be used to help prevent a denial of service attack.

..... [1]

Q 23) Winter 2019 P13

1 A library has a system that allows customers to check out the books that they want to borrow.

Each book has a barcode that can be used to identify the book.

(b) The data stored by the library is archived at the end of each day. The archive is held on a server in the library office. The data is encrypted with an 8-bit key. As some of the data is confidential, the library wants to make the encryption more secure.

(i) State how the library could make the encryption more secure.

.....

..... [1]

(ii) The term used to describe data before it is encrypted is plain text.

State the term used to describe encrypted data.

..... [1]

6 Jesse is taking his Computer Science examination. He answers five questions about ethics.

(a) For the first question, he writes the answer:

“This type of software can be copied and shared without the permission of the owner.”

State what Jesse is describing.

..... [1]

(b) For the second question, he writes the answer:

“With this type of software, the owner still retains the copyright for the software, but he gives away copies of it for free.”

State what Jesse is describing.

..... [1]

(c) For the third question, he writes the answer:

“This type of software is often a trial version of the full software. To use the full version the user normally needs to pay a fee.”

State what Jesse is describing.

..... [1]

(d) For the fourth question, he writes the answer:

“This is when a person copies another person’s computer program and tries to claim it as his own.”

State what Jesse is describing.

..... [1]

(e) For the fifth question, he writes the answer:

“This is the legal protection that a person can obtain, to provide protection against his work being stolen.”

State what Jesse is describing.

..... [1]

(c) The website owners are also concerned about the ethical issues of copyright and plagiarism.

(i) State what is meant by the term copyright.

.....
..... [1]

(ii) State what is meant by the term plagiarism.

.....
..... [1]

Q 26) Summer 20 P12) 3 A company collects and stores data about its customers. The data is stored on a server in the company's office. The data is transmitted to cloud storage to create a back-up. The data is encrypted using symmetric encryption before it is sent to the cloud storage.

(a) Describe how the data is encrypted.

.....
.....
.....
.....
.....
.....
.....
.....
.....
..... [4]

(b) Give **three other** methods that can be used to secure the data in the office.

Method 1

.....

Method 2

.....

Method 3

..... [3]

5 Meena uses a browser to research information for her business.

(a) Give **three** functions of a browser.

1

2

3 [3]

(b) Meena buys products for her business using the Internet.

The Transport Layer Security (TLS) protocol is used for transferring data when she buys products. One layer of the TLS protocol is the handshake layer.

(i) Describe the purpose of the handshake layer.

.....
.....
.....

[2]

(ii) Identify the other layer of the TLS protocol.

.....

[1]

(iii) Identify another protocol that can be used to transfer data securely.

.....

[1]

(c) Meena visits a website to buy products for her business.

The browser uses a small file to store the details of the products she views. This allows the website to display advertisements for other products she may like.

The small file also stores her log-in details. Give the name of this type of file.

..... [1]

10 Uma is concerned about risks that she may encounter when using the Internet.

Two of the risks she is concerned about are phishing and pharming.

(a) Give **one** similarity and **two** differences between phishing and pharming.

Similarity

.....
.....

Difference 1

.....
.....

Difference 2

.....
.....

[3]

(b) Identify **two** other risks that Uma could encounter when using the Internet.

Risk 1

Risk 2

[2]

(c) Uma uses a firewall to secure the data on her computer.

(i) Uma tells her friend that a firewall can only be software-based.

Tick (✓) to show whether Uma is **Correct** or **Incorrect**.

[1]

Correct

Incorrect

(ii) Describe how the firewall helps to keep Uma's data secure.

.....

.....

.....

.....

.....

.....

.....

.....

.....

.....

[4]

Q 27) 15a Summer 20 P11

7 Hans has a website selling comic books. Customers can create an account to buy the comic books. Customers enter a username and password to log in to their account.

(a) Customers may worry about keylogging software being used to gain unauthorised access to their account.

(i) Describe how keylogging software can be used to gain unauthorised access to a customer’s account.

.....
.....
.....
.....
.....
.....
.....
.....
.....

[4]

(ii) Identify a feature that Hans can add to the website to limit the threat of keylogging software.

.....

[1]

(b) Hans makes sure data transmission for his website is secure.

(i) State how customers can check that the personal details they enter into the website will be transmitted securely.

.....
.....

[1]

(ii) Explain how a customer’s browser checks that the website is secure.

.....
.....
.....
.....
.....
.....
.....
.....

[4]

Q 29) Winter 20 P13

6 Elsa writes a paragraph in an examination about encryption.

There are several terms missing from the paragraph.

Complete the paragraph using the list of given terms. Not all terms may need to be used.

Some terms may be used more than once.

- algorithm • alphanumeric • cookie • cypher
- key • padlock • plain • word processed

The data is encrypted using a This is an
 that is used to scramble the data. The data before
 encryption is known as text. When the data has been
 encrypted it is known as text. To read the encrypted
 data it needs to be decrypted using a [5]

Q 30) March 21 P12

2 (c) Users can buy the high definition photographs from the website. When a user buys a high definition photograph, a Secure Socket Layer (SSL) connection is created.

(i) Give **one** benefit of using an SSL connection.

.....
 [1]

(ii) Explain how the SSL connection is created.

.....

 [4]

6 Hacking is one type of Internet risk used to obtain personal data that is stored on a computer.

(a) Explain how a firewall can help prevent hacking.

.....

.....

.....

.....

.....

.....

.....

.....

.....

.....

[4]

(b) Identify and describe **two** other types of internet risk that are used to obtain personal data.

Internet risk 1

Description

.....

.....

.....

Internet risk 2

Description

.....

.....

.....

[6]

18a Summer 21 P11

3 A firewall can be used to help keep the data secure that is stored on a computer.

(a) The given paragraph describes how the firewall operates to help keep the data secure.

Complete the paragraph using the most appropriate terms from the given list. Not all of the terms on the list need to be used.

- Accept • Criteria • Hacking • Input • Network • Outgoing
- Output • Processor • Reject • Software • Store • Storage

A firewall can be or hardware based. It monitors traffic between the computer and the The user sets for the traffic. The firewall will or the traffic based

on this. It can help prevent and malicious software that could be a threat to the security of the data. [6]

(b) Identify three other methods that could be used to keep the data secure.

Method 1

Method 2

Method 3 [3]

3(a)	One mark per each correct term in the correct order. – Software – Network – Criteria – Accept // reject – Reject // accept – Hacking	6
3(b)	Any three from: – Password – Biometrics (device) – Encryption – Physical methods (e.g. locks) – Two-factor authentication // Two-step verification – Anti-viruses	3

18b Summer 21 P12) 4 Three types of Internet security risk are virus, spyware and denial of service (DoS) attack.

(a) Six statements are given about Internet security risks. [6]

Statement	Virus (✓)	Spyware (✓)	Denial of service (✓)
captures all data entered using a keyboard			
can be installed onto a web server			
prevents access to a website			
is malicious code on a computer			
is self-replicating			
damages the files on a user's hard drive			

(b) Identify three other types of Internet security risks.

- 1
- 2
- 3 [3]

(c) Some Internet security risks can maliciously damage data. Data can also be damaged accidentally. State three ways that data could be accidentally damaged.

- 1
- 2
- 3 [3]

4(a)	One mark per each correct row. <table border="1" style="width: 100%; border-collapse: collapse;"> <thead> <tr> <th style="width: 60%; text-align: center;">Statement</th> <th style="width: 15%; text-align: center;">Virus (✓)</th> <th style="width: 15%; text-align: center;">Spyware (✓)</th> <th style="width: 10%; text-align: center;">Denial of service (✓)</th> </tr> </thead> <tbody> <tr> <td style="text-align: center;">captures all data entered using a keyboard</td> <td></td> <td style="text-align: center;">✓</td> <td></td> </tr> <tr> <td style="text-align: center;">can be installed onto a web server</td> <td style="text-align: center;">✓</td> <td style="text-align: center;">✓</td> <td></td> </tr> <tr> <td style="text-align: center;">prevents access to a website</td> <td></td> <td></td> <td style="text-align: center;">✓</td> </tr> <tr> <td style="text-align: center;">is malicious code on a computer</td> <td style="text-align: center;">✓</td> <td style="text-align: center;">✓</td> <td></td> </tr> <tr> <td style="text-align: center;">is self-replicating</td> <td style="text-align: center;">✓</td> <td></td> <td></td> </tr> <tr> <td style="text-align: center;">damages the files on a user's hard drive</td> <td style="text-align: center;">✓</td> <td></td> <td></td> </tr> </tbody> </table>	Statement	Virus (✓)	Spyware (✓)	Denial of service (✓)	captures all data entered using a keyboard		✓		can be installed onto a web server	✓	✓		prevents access to a website			✓	is malicious code on a computer	✓	✓		is self-replicating	✓			damages the files on a user's hard drive	✓			6
Statement	Virus (✓)	Spyware (✓)	Denial of service (✓)																											
captures all data entered using a keyboard		✓																												
can be installed onto a web server	✓	✓																												
prevents access to a website			✓																											
is malicious code on a computer	✓	✓																												
is self-replicating	✓																													
damages the files on a user's hard drive	✓																													
4(b)	Any three from: – Phishing – Pharming – Hacking // cracking	3																												
4(c)	Any three from: – Human error – Power failure/surge – Hardware failure – Software failure – Fire – Flood	3																												

6 Cookies can be used to store a user's personal data and online browsing habits.

(a) A cookie could be used to automatically enter a user's payment details when the user makes a purchase online.

Describe how cookies can be used to store and automatically enter a user's payment details.

.....
.....
.....
.....
.....
.....
.....

[3]

(b) Explain why a user may be concerned about their personal data and online browsing habits being stored in cookies.

.....
.....
.....
.....
.....
.....
.....
.....
.....

[4]

<p>6(a)</p>	<p>Any three from:</p> <ul style="list-style-type: none"> - Webserver sends (cookie) file to user's browser - User's payment details stored in encrypted text file // data is encrypted to be stored - Cookie file is stored by browser/on user's HDD/SSD - When user revisits website, webserver requests cookie file // webserver can access the data stored in the cookie file (to automatically enter details) - ... and browser sends cookie file back to webserver (to automatically enter the details) 	<p>3</p>
<p>6(b)</p>	<p>Four from:</p> <ul style="list-style-type: none"> - User does not see what information is stored // might collect data that user does not know about ... - ... so, user may feel their privacy is affected - A profile could be built about the user ... - ... that could expose a user's identity // lead to identity theft - Sensitive information stored in cookies could be intercepted in transmission ... - Other websites could gain access to the cookies stored on a user's computer ... - Computer could be hacked to obtain data stored in cookies ... - ... so, payment information could be stolen and used by a third party 	<p>4</p>

18c Summer 21 P13

4 Spencer finds out that his online music account has been accessed by an unauthorised person. He believes his personal details for the account were obtained using phishing.

(a) Explain how the personal details could have been obtained using phishing.

.....

.....

.....

.....

.....

.....

.....

.....

.....

.....

[3]

(b) Give two other Internet security risks that could have been used to obtain the personal details.

1

2

[2]

4(a)	<ul style="list-style-type: none"> - Legitimate looking/fake email sent to user - ... that contains a link to a fake website - User clicks link and enters personal details (into fake website) 	3
4(b)	Any two from: <ul style="list-style-type: none"> - Pharming - Spyware - Hacking/cracking 	2

7 Marco uses his computer for work. The data he uses on a daily basis is valuable to his business. Marco is concerned about his data being accidentally damaged. Human error, such as incorrectly removing external storage devices, is one way that the data can be accidentally damaged.

(a) Identify two other ways that data can be accidentally damaged.

- 1
- 2 [2]

(b) Removing storage devices correctly from the computer can help prevent data being accidentally damaged.

Give two other ways that accidental damage to data can be prevented.

- 1
- 2 [2]

7(a)	Any two from: <ul style="list-style-type: none"> - Hardware failure - Software failure - Power failure/surge - Fire - Flood - Natural disaster 	2
7(b)	Any two from: <ul style="list-style-type: none"> - Use verification methods before deleting files - Keep data in a fireproof box - Do not drink liquids near a computer - Use surge protection // UPS - Correct shutdown procedures - Access rights - Back data up 	2

18a Summer 21 P11

4 Two internet risks are phishing and pharming.

Describe what is meant by phishing and pharming.

Phishing

.....

.....

.....

.....

.....

Pharming

.....

.....

.....

.....

.....

[6]

4	<p>Any six from:</p> <p>Phishing</p> <ul style="list-style-type: none"> - Legitimate looking email sent to user - encourages user to click a link that directs user to a fake website - User encouraged to enter personal details into a fake website // designed to obtain personal details from a user <p>Pharming</p> <ul style="list-style-type: none"> - Malicious code/malware is downloaded/installed // software downloaded without users' knowledge - ... that re-directs user to fake website (when legitimate URL entered) - User encouraged to enter personal details into a fake website // designed to obtain personal details from a user 	6
---	---	---

Marking Scheme

Q 1) Summer 2015 P11

4 1 mark per correct word

- 1 protocol
 - 2 web server name
 - 3 file name
- } accept these three items in any order

HTML tags/textfirewallproxy server

6 (a) virus

any **two** from:

- program/software that replicates/copies itself
- can delete or alter files/data stored on a computer
- can make the computer "crash"/run slow

pharmingany **two** from:

- malicious code/software installed on a user's hard drive/actual web server
- this code redirects user to a fake website (without their knowledge)
- to obtain personal/financial information/data

phishingany **two** from:

- legitimate-looking emails sent to a user
- as soon as recipient opens/clicks on link in the email/attachment ...
- ... the user is directed to a fake website (without their knowledge)
- To obtain personal/financial information/data

(b) (i) Any **two** from:

- spyware/key logging software can only pick up key presses
- using mouse/touchscreen means no key presses to log
- the numbers on the key pad are in random/non-standard format, which makes it more difficult to interpret

(ii) 1 mark for name and 1 mark for description

any **one** from:

chip and PIN reader

- only the user and the bank know which codes can be generated

request user name

- additional security together with password/PIN

anti-virus

- removes/warns of a potential virus threat which can't be passed on to customers

firewall

- (helps) to protect bank computers from virus threats and hacking

encryption

- protects customer data by making any hacked information unreadable

security protocol

- governs the secure transmission of data

Biometric

- to recognise user through the use of, e.g. facial/retina/finger print

Alerts

- users IP/MAC address is registered and user is alerted through, e.g. SMS if account is accessed through an unregistered address

Q 3) Winter 2015 P12

- 1 1 mark for each risk + 1 mark for corresponding reason why it is a risk and 1 mark for minimisation

Risk:	hacking
Reason:	illegal/unauthorised access to data deletion/amendment of data
Minimised:	use of passwords/user ids use of firewalls encrypt data/encryption
Risk:	virus
Reason:	can corrupt/delete data cause computer to crash/run slow can fill up hard drive with data
Minimised:	<u>use of /run</u> anti-virus (software) do not download software or data from unknown sources
Risk:	spyware/key logging (software)
Reason:	can read key presses/files/monitors on a user's computer
Minimised:	<u>use of/run</u> anti-spyware (software) use data entry methods such as drop-down boxes to minimise risk
Risk:	phishing
Reason:	<u>link/attachments</u> takes user to fake/bogus website website obtains personal/financial data
Minimised:	do not open/click emails/attachments from unknown sources some firewalls can detect fake/bogus websites
Risk:	pharming
Reason:	redirects user to fake/bogus website redirection obtains personal/financial data
Minimised:	only trust secure websites, e.g. look for <u>https</u> check the URL matches the intended site
Risk:	credit card fraud/identity theft
Reason:	loss of money due to misuse of card/stealing data
Minimised:	set passwords encrypt data/encryption
Risk:	cracking
Reason:	illegal/unauthorised access to data
Minimised:	setting strong passwords encrypt data/encryption

Q 4) Winter 2015 P13

(b) 1 mark for each CORRECT row

Statement	Firewall	Proxy server
Speeds up access of information from a web server by using a cache		✓
Filters all Internet traffic coming into and out from a user's computer, intranet or private network	✓	✓
Helps to prevent malware, including viruses, from entering a user's computer	✓	
Keeps a list of undesirable websites and IP addresses	✓	✓

(c) **one** mark for method + **one** mark for linked reason (maximum 6 marks)

- back up files...
- ...on a regular basis/to another device/to the cloud
- set data to read only...
- ...to prevent accidental editing
- save data on a regular basis...
- ...to prevent loss/corruption of data in unexpected shutdown/failure
- use correct shut down/start up procedures...
- ...to prevent damage to components/stored files
- use correct procedures before disconnecting portable storage device...
- ...to prevent damage to device/data corruption
- keep storage devices in a safe place...
- ...away from fire hazards

10 symmetric encryption

encryption key

plain text

encryption algorithm

cypher text

Q 5) Winter 2015 P11

3 (a)

Statement	True	False
Cookies can destroy or modify data in a computer without the user's knowledge		✓
Cookies generate website pop-ups		✓
Cookies allow a website to detect whether a viewer has viewed specific web pages	✓	

- 6 (a) Any **one** from:
- jumbling up/scrambling characters so that message makes no sense
 - requires an encryption key to encrypt data
 - need decryption key to decipher encrypted message

(b) Uses the same key to encrypt and decrypt message

(c) 1 mark for correct name in box

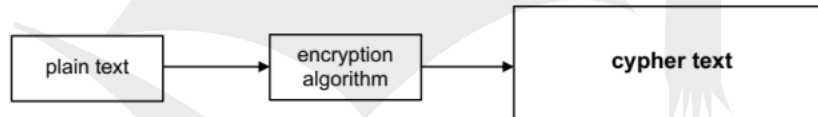

Q 6) Summer 2016 P11 & P13

6 (a) Any **one** from:

- protocol ends in "s"
- use of https

(b) Any **three** from:

- requests web server to identify itself/view the (SSL) certificate
- receives a copy of the (SSL) certificate, sent from the webserver
- checks if SSL certificate is authentic/trustworthy
- sends signal back to webserver that the certificate is authentic/trustworthy
- starts to transmit data once connection is established as secure
- if website is not secure browser will display an open padlock/warning message

8 (a) (i) Any **two** from:

- to protect against key logging software/spyware
- can stop key presses being recorded
- can stop key presses being relayed
- drop down boxes cannot be recorded as key presses
- drop down boxes can be placed in different location on the screen each time (to overcome screen capture issues)

(ii) Any **one** from:

- hacker never finds all characters on the first hack
- makes it more difficult for hackers to find the order of the characters
- hacker needs to hack the system several times to gain the whole password
- shoulder surfing will not give person full password

(b) Any **two** from:

- fingerprint scanner
- face recognition software
- retina scanner/iris scanner
- voice recognition software

10

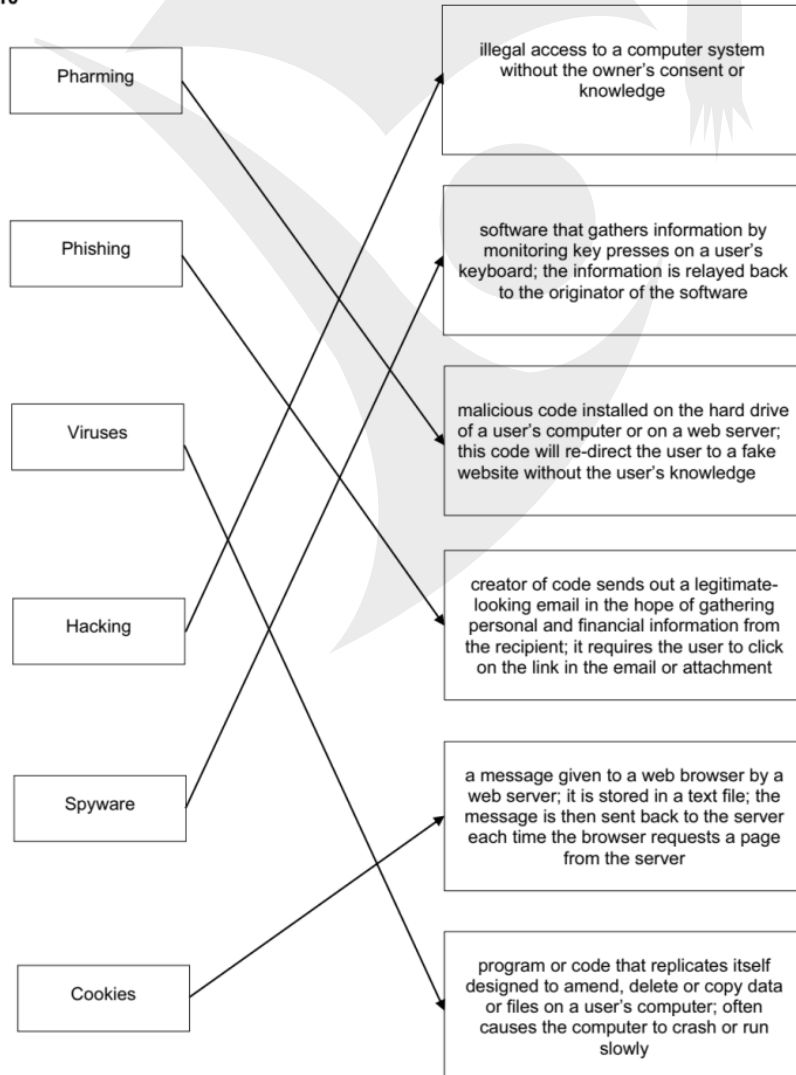

Q 8) Winter 2016 P12

Page 4	Mark Scheme	Syllabus	Paper
	Cambridge IGCSE – October/November 2016	0478	12

5 (a) 112 [1]

(b) 56 [1]

(c) divided by 2 // value 112 was halved // multiplied by 0.5 [1]

(d) (i)

0	0	0	0	1	1	1	0
---	---	---	---	---	---	---	---

 [1]

(ii) 14 [1]

- (e) Any **two** from:
- run out of places to the right of register / at the end of register
 - right-most 1 would be lost
 - number would become 3 instead of 3.5
 - loss of precision
- [2]

- 9 (a) Any **two** from:
- a large number of requests are sent to the network/server all at once
 - designed to flood a network/server with useless traffic/requests
 - the network/server will come to a halt/stop trying to deal with all the traffic/requests
 - prevents users from gaining access to a website/server
- [2]

(b) 1 mark for each security threat and 1 mark for matching description

Security threat	Description
Viruses	- software that replicates - causes loss/corruption of data // computer may "crash"/run slow
Hacking/cracking	- illegal/ unauthorised access to a system/data
Phishing	- a <u>link/attachment</u> sends user to fake website (where personal data may be obtained)
Pharming	- malicious code installed on user's hard drive / computer - user is <u>redirected</u> to a fake website (where personal data may be obtained)
Spyware/key logger	- send/relay key strokes to a third party

[4]

Q 9) Winter 2016 P11& 13

- 2
- Hacking
 - Virus
 - Cookies
 - Cracking
 - Pharming
- [5]

(c) 1 mark for security measure, 1 mark for description.

Any **two** from:

- Encryption
- If the data is accessed or stolen it will be meaningless
- Biometric device
- Can help prevents unauthorised access to the system (only award once)
- Firewall
- Can alert to show unauthorised access attempt on the system
- Can help prevent unauthorised access to the system (only award once)
- Can help protect against viruses and malware entering the system
- Anti-spyware
- Can stop the keys being logged that, when analysed, would reveal the password to the data

[4]

10

- (d) - record (layer)
- handshake (layer)

[2]

Q 10) March 2017 India

Question	Answer	Marks																										
4(a)	∞ a v m v e q n d i z m h (2 marks, 1 for each correct word)	2																										
4(b)	<table border="1" style="width: 100%; text-align: center;"> <tr> <td>v</td><td>w</td><td>x</td><td>y</td><td>z</td><td>a</td><td>b</td><td>c</td><td>d</td><td>e</td><td>f</td><td>g</td><td>h</td><td>i</td><td>j</td><td>k</td><td>l</td><td>m</td><td>n</td><td>o</td><td>p</td><td>q</td><td>r</td><td>s</td><td>t</td><td>u</td> </tr> </table> <p>2 marks</p> <ul style="list-style-type: none"> ∞ shift right ∞ all characters shifted five places 	v	w	x	y	z	a	b	c	d	e	f	g	h	i	j	k	l	m	n	o	p	q	r	s	t	u	2
v	w	x	y	z	a	b	c	d	e	f	g	h	i	j	k	l	m	n	o	p	q	r	s	t	u			
4(c)	∞ the first cypher ∞ cannot deduce rest of cypher having identified some characters/more random substitution	2																										
Question	Answer	Marks																										
5	HTML – HyperText Markup Language / language used to create web pages http – hypertext transfer protocol / protocol used by web browsers https – hypertext transfer protocol secure / secure protocol used by web browsers	3																										

Question	Answer	Marks
9	Any four from, must include at least one difference: Text based password <ul style="list-style-type: none"> ∞ (a minimum number of) characters that can be typed at a keyboard ∞ set / can be changed by the user Biometric password <ul style="list-style-type: none"> ∞ a stored physical measurement e.g. fingerprint ∞ that is compared to a previously scanned human measurement Difference <ul style="list-style-type: none"> ∞ text based passwords are easier to hack than biometric passwords ∞ biometric passwords are unique to that person/cannot be shared 	4

Q 11) Summer 2017 P11

Question	Answer	Marks
7	<p>1 mark for correct line till 5 marks given.</p>	5

Q 12) Summer 2017 P12

Question	Answer	Marks
8(a)	<p>2 marks for SSL, 2 marks for Firewall</p> <p>SSL protocol Two from:</p> <ul style="list-style-type: none"> ∞ uses encryption ∞ encryption is asymmetric / symmetric / both ∞ makes use of (public and private) keys ∞ data is meaningless (without decryption key / if intercepted) <p>Firewall Two from:</p> <ul style="list-style-type: none"> ∞ helps prevent unauthorised access // helps prevent hacking ∞ checks that data meets criteria // identifies when data does not meet criteria ∞ acts as a filter for (incoming and outgoing) data // blocks any unacceptable data //allows acceptable data through 	4

Question	Answer	Marks
8(b)	<p>Six from:</p> <p>Encrypt the data so it cannot be understood by those not entitled to view it</p> <p>Password protected / biometrics to help prevent unauthorised access</p> <p>Virus checking software helps prevent data corruption or deletion ... identifies / removes a virus in the system ... <u>scans</u> a system for viruses</p> <p>Spyware checking software helps prevent data being stolen/copied/logged ... <u>scans</u> a system for spyware</p> <p>Drop-down input methods / selectable features to reduce risk of spyware / keylogging</p> <p>Physical method e.g. locked doors / CCTV timeout / auto log off ... to help prevent unauthorised access</p> <p>Network / company policies // training employees ... to educate users how to be vigilant</p> <p>Access rights allows users access to data that they have permission to view ... prevents users from accessing data that they do not have permission to view</p>	6

Question	Answer	Marks
11	<p>Seven from:</p> <p>Requested</p> <ul style="list-style-type: none"> ∞ a web browser is used ∞ user enters the URL / web address (into the address bar) // clicks a link containing the web address // clicks an element of the webpage ∞ the URL / web address specifies the protocol ∞ protocols used are Hyper Text Transfer Protocol (HTTP) / Hyper Text Transfer Protocol Secure (HTTPS) <p>Sent</p> <ul style="list-style-type: none"> ∞ the URL / web address contains the domain name ∞ the Internet Service Provider (ISP) looks up the IP address of the company ∞ the domain name is used to look up the IP address of the company ∞ the domain name server (DNS) stores an index of domain names and IP addresses ∞ web browser sends a request to the web server / IP address <p>Received</p> <ul style="list-style-type: none"> ∞ Data for the website is stored on the company's web server ∞ webserver sends the data for the website back to the web browser ∞ web server uses the customer's IP address to return the data ∞ the data is transferred into Hyper Text Mark-up Language (HTML) ∞ HTML is interpreted by the web browser (to display the website) 	7

Q 13) Winter 2017 P12

2210/12

Cambridge O Level – Mark Scheme
PUBLISHEDOctober/November
2017

Question	Answer	Marks
5(a)	<p>Any four from:</p> <ul style="list-style-type: none"> ∞ Data / files ∞ Stored in a <u>text file</u> ∞ Downloaded to a user's computer when a website is visited // webserver sends to web browser ∞ Stored on a user's computer ∞ Stored by a browser ∞ Detected by the website when it is visited again 	4
5(b)	<p>Any two from: e.g.</p> <ul style="list-style-type: none"> ∞ To store personal information/data ∞ To store login details ∞ To save items in an online shopping basket ∞ To track/save internet surfing habits // to track website traffic ∞ To carry out targeted advertising ∞ To store payment details ∞ To customise a webpage // to store user preferences ∞ Store progress in online games/quizzes 	2

Question	Answer	Marks
6	<p>1 mark for each correct term, in this order:</p> <ul style="list-style-type: none"> ∞ Interrupt ∞ Compiler ∞ ALU/Arithmetic and Logic Unit ∞ ARQ/Automatic repeat request 	4



10(a)	Any three from: <ul style="list-style-type: none"> ∞ It is a (security) protocol ∞ It encrypts data (sent over the web/network) ∞ It is the updated version of SSL ∞ It has <u>two</u> layers ∞ It has a handshake layer ∞ It has a record layer 	3
10(b)	1 mark for each correct application, examples could include: <ul style="list-style-type: none"> ∞ Online banking ∞ Online shopping // Online payment systems ∞ Email ∞ Cloud based storage ∞ Intranet/extranet ∞ VPN ∞ VoIP ∞ Instant messaging (IM) // social networking 	3

Q 14) Winter 2017 P13

Question	Answer	Marks																					
7	1 mark for each correct tick <table border="1" style="width: 100%; border-collapse: collapse;"> <thead> <tr> <th style="width: 70%;">Statement</th> <th style="width: 10%;">true (✓)</th> <th style="width: 20%;">false (✓)</th> </tr> </thead> <tbody> <tr> <td>Firewalls can monitor incoming and outgoing traffic.</td> <td style="text-align: center;">✓</td> <td></td> </tr> <tr> <td>Firewalls operate by checking traffic against a set of rules.</td> <td style="text-align: center;">✓</td> <td></td> </tr> <tr> <td>Firewalls cannot block access to a certain website.</td> <td></td> <td style="text-align: center;">✓</td> </tr> <tr> <td>Firewalls can be software and hardware.</td> <td style="text-align: center;">✓</td> <td></td> </tr> <tr> <td>Firewalls can act as intermediary servers.</td> <td></td> <td style="text-align: center;">✓</td> </tr> <tr> <td>Firewalls can block unauthorised traffic.</td> <td style="text-align: center;">✓</td> <td></td> </tr> </tbody> </table>	Statement	true (✓)	false (✓)	Firewalls can monitor incoming and outgoing traffic.	✓		Firewalls operate by checking traffic against a set of rules.	✓		Firewalls cannot block access to a certain website.		✓	Firewalls can be software and hardware.	✓		Firewalls can act as intermediary servers.		✓	Firewalls can block unauthorised traffic.	✓		6
Statement	true (✓)	false (✓)																					
Firewalls can monitor incoming and outgoing traffic.	✓																						
Firewalls operate by checking traffic against a set of rules.	✓																						
Firewalls cannot block access to a certain website.		✓																					
Firewalls can be software and hardware.	✓																						
Firewalls can act as intermediary servers.		✓																					
Firewalls can block unauthorised traffic.	✓																						

Question	Answer	Marks
8(a)	Any three from: <ul style="list-style-type: none"> - Human error (e.g. deleting/overwriting data) - Physical damage - Power failure/surge - Hardware failure - Software crashing 	3
8(b)	Any three from: <ul style="list-style-type: none"> - Online shopping // Online payment systems // Online booking - Email - Cloud based storage - Intranet/extranet - VPN - VoIP // video conferencing - Instant messaging (IM) // social networking // online gaming 	3

Question	Answer	Marks
8(c)	<p>1 mark for identifying, 1 mark for description</p> <ul style="list-style-type: none"> - Strong password - To make it difficult to hack an account - Biometric device - To use data that is difficult to fake as a password - TLS // Encryption - To make data meaningless if intercepted - To encrypt data that is exchanged (TLS only) - More secure than SSL (TLS only) - Anti-spyware (software) - To find and remove any spyware that is installed on a computer - To help stop key loggers recording key presses - Firewall - To help prevent unauthorised access to an account - Blocks any requests that do not meet/match the criteria - Authentication (card reader at home)/mobile security code app/two-step verification - To add another level of identification of the user - Use of drop-down boxes (or equivalent) - So key loggers cannot record the key presses - Proxy server - To divert an attack away from the main system 	6

Q 15) March 2018 P12 (India)

Question	Answer	Marks
2(a)	<p>Any three from:</p> <p>Scans files for viruses // detects/identifies a virus Can constantly run in background Can run a scheduled scan Can automatically updating virus definitions Can quarantine a virus Can delete a virus Completes heuristic checking Notifies user of a possible virus</p>	3

Question	Answer	Marks
2(b)	<p>Any three from:</p> <p>Use a firewall Use of a proxy server Do not use / download software / files from unknown sources Do not share external storage devices / USB pens Do not open / take care when opening attachments / link Do not connect computer to network / use as stand-alone computer Limiting access to the computer</p>	3

Question	Answer	Marks
3(a)	Byte 3 / 10110100	1
3(b)	<p>Odd parity used Counted / added the number 1's // Most Bytes have an odd number of 1's Byte 3 has an even number of 1's // Byte 3 didn't follow odd parity</p>	3



Q 16) Summer 2018 P11

10(c)	<p>Any two from e.g. :</p> <ul style="list-style-type: none"> - To store items that a customer has added to an online shopping basket - To store a customer's credit card details - To store log-in details - To track what product a customer browses // Track music preferences - Targeted advertising // making recommendations - Personalises/customises the experience - Shows who are new and returning customers - To speed up log-in times - To speed up/allow single click purchases - Improves the experience 	2
-------	--	---

Question	Answer	Marks
10(d)	<p>Any four from:</p> <ul style="list-style-type: none"> - Prevents direct access to the webservice // Sits between user and webservice - If an attack is launched it hits the proxy server instead // can be used to help prevent DDOS // help prevent hacking of webservice - Used to direct invalid traffic away from the webservice - Traffic is examined by the proxy server // Filters traffic - If traffic is valid the data from the webservice will be obtained by the user - If traffic is invalid the request to obtain data is declined - Can block requests from certain IP addresses 	4

Q 17) Summer 2018 P12

12(a)(i)	Encryption	1
12(a)(ii)	<p>Any five from:</p> <ul style="list-style-type: none"> - Her personal details before encryption is the <u>plain text</u> - The plain text/her personal details is encrypted using an encryption <u>algorithm</u> - The plain text/her personal details is encrypted using a <u>key</u> - The encrypted text is <u>cypher/cipher text</u> - The key is transmitted separately (from the text) - The <u>key</u> is used to decrypt the cypher text (after transmission) 	5
12(b)	<p>Any three from a single error method:</p> <ul style="list-style-type: none"> - Checksum - Calculation carried out on data - (checksum/calculated) value sent with data - recalculated after transmission and compared to original - If they do not match an error is present - ARQ - uses acknowledgment and timeout - A request is sent with data to acknowledge all data is received - Acknowledgement sent back to say all data is received - If no acknowledgement is received in a time frame an error in transmission detected / data automatically resent. 	3

Q 19) Winter 2018 P13

Question	Answer	Marks
6	<p>1 mark for method name, 1 mark for description e.g.</p> <p>Backups</p> <ul style="list-style-type: none"> ∞ Make a copy of the data ∞ Copy stored away from main computer ∞ Data can be restored from backup <p>Anti-virus</p> <ul style="list-style-type: none"> ∞ Scans computer for viruses ∞ Software to detect/remove viruses ∞ Can prevent data being corrupted by viruses <p>Firewall</p> <ul style="list-style-type: none"> ∞ Hardware or software that monitors network traffic ∞ To help prevent hackers gaining access / deleting data <p>Password/Biometrics</p> <ul style="list-style-type: none"> ∞ To help protect files / computer from unauthorised access <p>Restricted access</p> <ul style="list-style-type: none"> ∞ To stop users downloading/installing software that could harm <p>Verification</p> <ul style="list-style-type: none"> ∞ Message e.g. to ask if definitely want to delete <p>Physical methods</p> <ul style="list-style-type: none"> ∞ Locks/alarms/CCTV to alert/deter unauthorised access 	6

Q 20) March 2019 P12

7	<p>For each of three risks Naming the risk – 1 mark, describing the risk – 1 mark:</p> <ul style="list-style-type: none"> - Hacking ... - ... when a person tries to gain unauthorised access to a computer system - ... data can be deleted/corrupted by hacker - Malware ... - ... a software program designed to damage data / disrupt the computer system - ... replicates itself and fills the hard disk - Virus ... - ... a program that replicates itself to damage / delete files <p>NOTE: Multiple kinds of malware can be awarded if listed and given a matching description e.g. trojan horse, worm.</p>	6
---	--	---

Q 22) Summer 2019 P12

5	<ul style="list-style-type: none"> - Password protection - Password is released on the release date - Encryption - Encryption key is released on the release date 	4
---	---	---

6(a)	<p>Structure</p> <ul style="list-style-type: none"> - This is the layout of the web page - e.g. placing an image alongside some text // example of tag, such as <div> <p>Presentation</p> <ul style="list-style-type: none"> - This is the formatting/style of the web page - e.g. the colour that is applied to some text // example of tag, such as <font-color> 	4																		
6(b)	<p>1 mark per each correct row.</p> <table border="1"> <thead> <tr> <th>Statement</th> <th>True (✓)</th> <th>False (✓)</th> </tr> </thead> <tbody> <tr> <td>Cookies can be used to store a customer's credit card details</td> <td>✓</td> <td></td> </tr> <tr> <td>Cookies can be used to track the items a customer has viewed on a website</td> <td>✓</td> <td></td> </tr> <tr> <td>Cookies will corrupt the data on a customer's computer</td> <td></td> <td>✓</td> </tr> <tr> <td>Cookies are downloaded onto a customer's computer</td> <td>✓</td> <td></td> </tr> <tr> <td>Cookies can be deleted from a customer's computer</td> <td>✓</td> <td></td> </tr> </tbody> </table>	Statement	True (✓)	False (✓)	Cookies can be used to store a customer's credit card details	✓		Cookies can be used to track the items a customer has viewed on a website	✓		Cookies will corrupt the data on a customer's computer		✓	Cookies are downloaded onto a customer's computer	✓		Cookies can be deleted from a customer's computer	✓		5
Statement	True (✓)	False (✓)																		
Cookies can be used to store a customer's credit card details	✓																			
Cookies can be used to track the items a customer has viewed on a website	✓																			
Cookies will corrupt the data on a customer's computer		✓																		
Cookies are downloaded onto a customer's computer	✓																			
Cookies can be deleted from a customer's computer	✓																			
6(c)	<ul style="list-style-type: none"> - Several/multiple bits are transmitted at a time/simultaneously - Several/multiple wires are used - Data is transmitted in both directions ... - ... at the same time/simultaneously 	4																		
6(d)	<p>One from:</p> <ul style="list-style-type: none"> - Uniform resource locator - The website's address - User friendly version of the IP address 	1																		
6(e)(i)	<p>Four from:</p> <ul style="list-style-type: none"> - Designed to deny people access to a website - A large number/numerous requests are sent (to a server) ... - ... all at the same time - The server is unable to respond/struggles to respond to all the requests - The server fails/times out as a result 	4																		
6(e)(ii)	<p>One from:</p> <ul style="list-style-type: none"> - Proxy server - Firewall 	1																		

Q 23) Winter 2019 P13

1(b)(i)	∞ Increase the length of the key // make key 12-bit, etc.	1
1(b)(ii)	∞ Cypher text	1

2210/13

Cambridge O Level – Mark Scheme
PUBLISHED

October/November 2019

Question	Answer	Marks
1(b)(iii)	<p>Six from:</p> <ul style="list-style-type: none"> ∞ The system could use <u>odd</u> or <u>even</u> parity ∞ A parity bit is added ∞ The data is checked to see if it has incorrect/correct parity // by example <p>∞ If parity is correct no error is found</p> <ul style="list-style-type: none"> ∞ An acknowledgement is sent that data is received correctly ∞ The next packet of data is transmitted <p>∞ If incorrect parity is found an error has occurred</p> <ul style="list-style-type: none"> ∞ A signal is sent back to request the data is resent ∞ The data is resent until data is received correctly/timeout occurs 	6



6) Free software, Freeware, Shareware, Plagiarism, Copyright

2210/13

Cambridge O Level – Mark Scheme
PUBLISHED

October/November 2019

Question	Answer	Marks
8	<p>Four from:</p> <ul style="list-style-type: none"> ∞ A hacker could have hacked the network ... ∞ ... and downloaded the malware onto the network ∞ Clicking a link/attachment/downloaded a file from an email/on a webpage ... ∞ ... the malware could have been embedded into the link/attachment/file ∞ Opening an infected software package ... ∞ ... this would trigger the malware to download onto the network ∞ Inserting an infected portable storage device ... ∞ ... when the drive is accessed the malware is downloaded to the network ∞ Firewall has been turned off ... ∞ ... so malware would not be detected/checked for when entering network ∞ Anti-malware has been turned off ... ∞ ... so malware is not detected/checked for when files are downloaded 	4

Q 24) Winter 2019 P12

2210/12

Cambridge O Level – Mark Scheme
PUBLISHED

October/November 2019

Question	Answer	Marks
7(c)	<p>Three from:</p> <ul style="list-style-type: none"> ∞ Hypertext Transfer Protocol Secure // It is a protocol ... ∞ ... that is a set of rules/standards ∞ Secure version of <u>HTTP</u> ∞ Secure website // secures data ∞ Uses TLS / SSL ∞ Uses encryption 	3

Question	Answer	Marks
10(a)	<p>Four from:</p> <ul style="list-style-type: none"> ∞ Validation method ∞ Used to check data entry ∞ Digit is calculated from data // by example ∞ Digit is appended / added to data ∞ Digit is recalculated when data has been input ∞ Digits are compared ∞ If digits are different, error is detected // If digits match, no error is detected 	4
10(b)	<p>Six from (maximum three marks per security method):</p> <ul style="list-style-type: none"> ∞ Firewall ... <ul style="list-style-type: none"> ∞ ... Monitors the traffic ∞ ... Blocks any traffic that doesn't meet the criteria / rules ∞ (Strong) password // biometric ... <ul style="list-style-type: none"> ∞ ... Data cannot be accessed without the use of the password / bio data ∞ ... Prevent brute force attacks ∞ Encryption ... <ul style="list-style-type: none"> ∞ ... Data will be scrambled ∞ ... Key is required to decrypt the data ∞ ... If data is stolen it will be meaningless ∞ Physical security methods ... <ul style="list-style-type: none"> ∞ ... The physical security will need to be overcome ∞ ... This can help deter theft of the data ∞ Antispyware ... <ul style="list-style-type: none"> ∞ ... will remove any spyware from system ∞ ... will prevent data being relayed to a third party 	6

Q 25) March 20 P12

Question	Answer	Mark
2(c)(i)	<p>Any two from:</p> <ul style="list-style-type: none"> • Scrambles data • ... making it meaningless/unintelligible • Uses an algorithm / key • Data / plain text is changed to cipher text 	2
2(c)(ii)	<p>Any one from:</p> <ul style="list-style-type: none"> • Increase the length of the key // use more than 128 bits • Uses a more complex encryption algorithm 	1

0478/12

Cambridge IGCSE – Mark Scheme
PUBLISHED

March 2020

Question	Answer	Mark
2(d)	<p>Any six from (max four for identification of method only):</p> <ul style="list-style-type: none"> • Backups • ... if data is lost can be replaced • Install antivirus // Anti malware • ... detects/deletes viruses that could corrupt/delete data • Install firewall • ... helps prevent hackers gaining access and deleting/corrupting data • Password / Biometrics • Two factor authentication // two-step verification • ... helps prevent unauthorised access and the deletion/corruption of data • Access rights • ... helps prevent users accessing data they should not see and deleting it • Network/usage policy • ... gives users guidance on data use // by example • Surge protection // Uninterrupted power supply (UPS) • ... prevents loss of data that has not been saved • ... prevents damage to hardware (that stores data) • Physical method // by example • ... helps prevent unauthorised access and the deletion/corruption of data 	6

0478/12

Cambridge IGCSE – Mark Scheme
PUBLISHED

March 2020

Question	Answer	Mark
8(a)	<p>Any five from:</p> <ul style="list-style-type: none"> • Sends the URL of the website • ... to a DNS to find the IP address • Connects to the webserver (using the IP address) ... • ... using HTTP / HTTPS • Renders/Translates the HTML • Runs active/client-side scripts built into webpages • Manages SSL/TLS certificate process • Stores/retrieves cookies 	5
8(b)	<p>Any three from:</p> <ul style="list-style-type: none"> • Webserver is sent multiple requests // Requests flood the webserver ... • ... at the same time • Webserver crashes / runs slow • Designed to prevent access to e.g. a website // Stops legitimate requests being processed/serviced 	3
8(c)(i)	<ul style="list-style-type: none"> • A law/legislation that requires permission to use intellectual property / other people's work 	1
8(c)(ii)	<p>Any one from:</p> <ul style="list-style-type: none"> • To claim other's work as your own • To use other people's work without consent / acknowledgement • Theft of intellectual property 	1



Q 26) Summer 20 P12

2210/12

Cambridge O Level – Mark Scheme
PUBLISHED

May/June 2020

Question	Answer	Marks
3(a)	Any four from: <ul style="list-style-type: none"> - Encryption key is used - Encryption algorithm is used - Encryption key / algorithm is applied to plain text - ... to convert it into cypher text - Same key is used to encrypt and decrypt the text 	4
3(b)	Any three from: <ul style="list-style-type: none"> - Firewall - Password - Proxy server - Physical methods (by example e.g. CCTV, Locks) - Access rights - <u>Asymmetric</u> encryption - Disconnect from network 	3

Question	Answer	Marks
5(a)	Any three from: <ul style="list-style-type: none"> - Convert HTML code - Display web pages - Check if a website is secure - Request web pages from a web server - Send URL/domain name - Runs active script - Store history/favourites/bookmarks - Create tabs 	3

2210/12

Cambridge O Level – Mark Scheme
PUBLISHED

May/June 2020

Question	Answer	Marks
5(b)(i)	<ul style="list-style-type: none"> - Carries out authentication of server and client - Handles encryption algorithms / keys 	2
5(b)(ii)	<ul style="list-style-type: none"> - Record layer 	1
5(b)(iii)	Any one from: <ul style="list-style-type: none"> - SSL - HTTPS 	1
5(c)	<ul style="list-style-type: none"> - Cookies 	1

Question	Answer	Marks
10(a)	<p>One mark for similarity, two marks for differences</p> <p>Similarity:</p> <ul style="list-style-type: none"> - Both are designed to steal personal data - They both pose as a real company/person <p>Differences:</p> <ul style="list-style-type: none"> - Pharming uses malicious code installed on hard drive - Phishing is in form of an email - Phishing requires use to follow a link / open an attachment 	3
10(b)	<ul style="list-style-type: none"> - Virus - Malware 	2
10(c)(i)	<ul style="list-style-type: none"> - Incorrect 	1
10(c)(ii)	<p>Any four from:</p> <ul style="list-style-type: none"> - Can help prevent hacking - Can monitor incoming and outgoing traffic - Can set criteria / rules are set for traffic - Can check whether traffic meets / defies criteria rules - Can rejects any traffic that does not meet / defies criteria 	4

Q 27) 15a Summer 20 P11

7(a)(i)	<p>Any four from:</p> <ul style="list-style-type: none"> - Keylogger is downloaded without knowledge (by example) - Keylogger records key presses - Data is relayed back to third party - Data is analysed // Patterns in data could reveal log-in details ... - ... details can then be used to log into the account 	4
7(a)(ii)	<p>Any one from:</p> <ul style="list-style-type: none"> - Use drop-down boxes for password - Two-step verification (by example) - Partial password requests - Onscreen / virtual keyboard 	1
7(b)(i)	<p>Any one from:</p> <ul style="list-style-type: none"> - Look for locked padlock / green padlock - Check for https 	1
7(b)(ii)	<p>Any four from:</p> <ul style="list-style-type: none"> - requests web server to identify itself // request to view the (SSL) certificate - receives a copy of the (SSL) certificate, sent from the webserver - checks if (SSL) certificate is authentic/trustworthy - sends signal back to webserver that the certificate is authentic/trustworthy 	4

Q 29) Winter 20 P13

4(a)	<p>Any four from:</p> <ul style="list-style-type: none"> - Browsers sends URL to DNS - ... using HTTP - DNS finds matching IP addresses for URL - ... and sends IP address to web browser - Web browser sends request to IP address/web server for web pages - Web pages are sent from web server to browser - Browser renders HTML to display web pages - Any security certificates are exchanged/authenticated // SSL/HTTPS is used to secure the data - ... encrypting any data sent 	4
------	---	---

4(b)	Any three from: <ul style="list-style-type: none"> - Hacking - Denial of service (DoS) - Malware - Virus <p>NOTE: three suitable types of malware can be awarded</p>	3
6	<ul style="list-style-type: none"> - Key // Algorithm - Algorithm // Key (must be opposite of first one) - Plain - Cypher - Key // Algorithm 	5
13(a)	Any one from: <ul style="list-style-type: none"> - Both are designed to steal/collect personal data - Both pretend to be a real company - Both use fake websites 	1
13(b)	<ul style="list-style-type: none"> - Phishing involves use of an email whereas pharming involves installing malicious code - Phishing involves clicking a link or an attachment whereas pharming creates a redirection 	2

Q 30) March 21 P12

2(c)(i)	<ul style="list-style-type: none"> - Data if intercepted cannot be understood // Data is encrypted // Data is scrambled // uses keys to encode/decode data 	1
2(c)(ii)	<p>Four from:</p> <ul style="list-style-type: none"> - Uses (digital) certificates -requested from web server by browser/client // browser/client asks web server to identify itself - Server send SSL/digital signature to browser/client - Client and server agree on encryption method to use - ... that contains the server's public key - Browser checks authenticity of certificate ... - ... then session key is generated - ... the transaction will begin // sends signal to server to start transmission 	4
6(a)	<p>Any four from:</p> <ul style="list-style-type: none"> - Monitors incoming and outgoing traffic - Allows the setting of criteria/blacklist/whitelist/by example - Blocks access to signals that do not meet requirements/criteria/blacklist/whitelist ... - ... sends signal to warn the user - Restrict access to specific applications - Blocks entry/exit by specific ports 	4

6(b)	<p>One mark for risk, two marks for description</p> <ul style="list-style-type: none">- Phishing- Legitimate looking email sent to user- Clicking on link/attachment takes user to fake website - Pharming- Software is installed on user's computer- Redirects (correct URL) to different/fraudulent website - Spyware (accept keylogger but do not award for MP3)- Software is installed on user's computer- Records key strokes // keylogger- Transmits data to third part for analysis	6
------	---	---

Ethics is a set of moral principles that govern the behaviour of a group or individual.

Computer Ethics

Computer ethics is set of moral principles that regulate the use of computers.

Some common issues of computer ethics include:

1. **INTELLECTUAL PROPERTY RIGHTS** – this covers, for example, copyright, plagiarism, cracking, software licencing.
2. **PRIVACY ISSUES** – this covers, for example, hacking, data protection and malware like virus, spyware or any illegal access to another person's personal data
3. **EFFECTS OF COMPUTERS ON SOCIETY** – this covers factors such as job losses, environmental effects, and social impacts and so on.

For example, while it is easy to duplicate copyrighted electronic (or digital) content, computer ethics would suggest that it is wrong to do so without the author's approval. And while it may be possible to access someone's personal information on a computer system, computer ethics would advise that such an action is unethical.

As technology advances, computers continue to have a greater impact on society. Therefore, computer ethics promotes the discussion of how much influence computers should have in areas such as artificial intelligence and human communication. As the world of computers evolves, computer ethics continues to create ethical standards that address new issues raised by new technologies.

Intellectual Property Rights:

Intellectual property (IP) is a category of property that includes intangible creations of the human intellect.

Examples of copyrightable works include movies, videos, photos, books, diaries, articles, and software.

Copyright is a legal concept, enacted by most governments, that grants the creator of an original work exclusive rights to its use and distribution, usually for a limited time, with the intention of enabling the creator of intellectual wealth (e.g. the photographer of a photograph or the author of a book) to receive compensation for their work and be able to financially support themselves.

Copyright is a form of intellectual property (as patents, trademarks and trade secrets are), applicable to any expressible form of an idea or information that is substantive and discrete.

Copyright Issues: Very briefly, copyright gives the author of a work the right...

- ...to reproduce the work.
- ...to permit copies to be made by others.

- ...to prepare derivative works.
- ...to display the copyrighted work publicly.

Plagiarism is the practice of taking someone else's work or ideas and passing them off as one's own.

“**Plagiarism** is the deliberate or reckless representation of another’s words, thoughts, or ideas as one’s own without attribution in connection with submission of academic work, whether graded or otherwise.” Plagiarism is considered academic dishonesty and a breach of Computer ethics. It is subject to sanctions like expulsion.

Plagiarism is not a crime *per se* but in academia and industry it is a serious ethical offense, and cases of plagiarism can constitute copyright infringement.

Cracking

Software cracking is the modification of software to remove or disable features which are considered undesirable by the person cracking the software, usually related to break license.

Software Licencing:

Following are types of software licence:

Freeware is copyrighted computer software which is made available for use free of charge, for an unlimited time. Authors of freeware often want to "give something to the community", but also want to retain control of any future development of the software.

The term **shareware** refers to commercial software that is copyrighted, but which may be copied for others for the purpose of their trying it out with the understanding that they will pay for it if they continue to use it.

Free software is computer software that is distributed along with its source code, and is released under terms that guarantee users the freedom to study, adapt/modify, and distribute the software.

Free Software	Freeware	Shareware
Without any copyright	With copyright	With copyright
With source code	Without source code	Without source
Free for lifetime	Free for lifetime	Free for trial period

ACM/IEEE Code of Ethics

1. **PUBLIC** – Software engineers shall act consistently with the public interest.
2. **CLIENT AND EMPLOYER** – Software engineers shall act in a manner that is in the best interests of their client and employer, consistent with the public interest.
3. **PRODUCT** – Software engineers shall ensure that their products and related modifications meet the highest professional standards possible.
4. **JUDGEMENT** – Software engineers shall maintain integrity and independence in their professional judgment.
5. **MANAGEMENT** – Software engineering managers and leaders shall subscribe to and promote an ethical approach to the management of software development and maintenance.
6. **PROFESSION** – Software engineers shall advance the integrity and reputation of the profession consistent with the public interest.
7. **COLLEAGUES** – Software engineers shall be fair to and supportive of their colleagues.
8. **SELF** – Software engineers shall participate in lifelong learning regarding the practice of their profession and shall promote an ethical approach to the practice of the profession.

Exam-style Questions

1 The ACM and IEEE set out eight principles for ethics and professional practice. The categories, with a short explanation, are shown in this diagram.

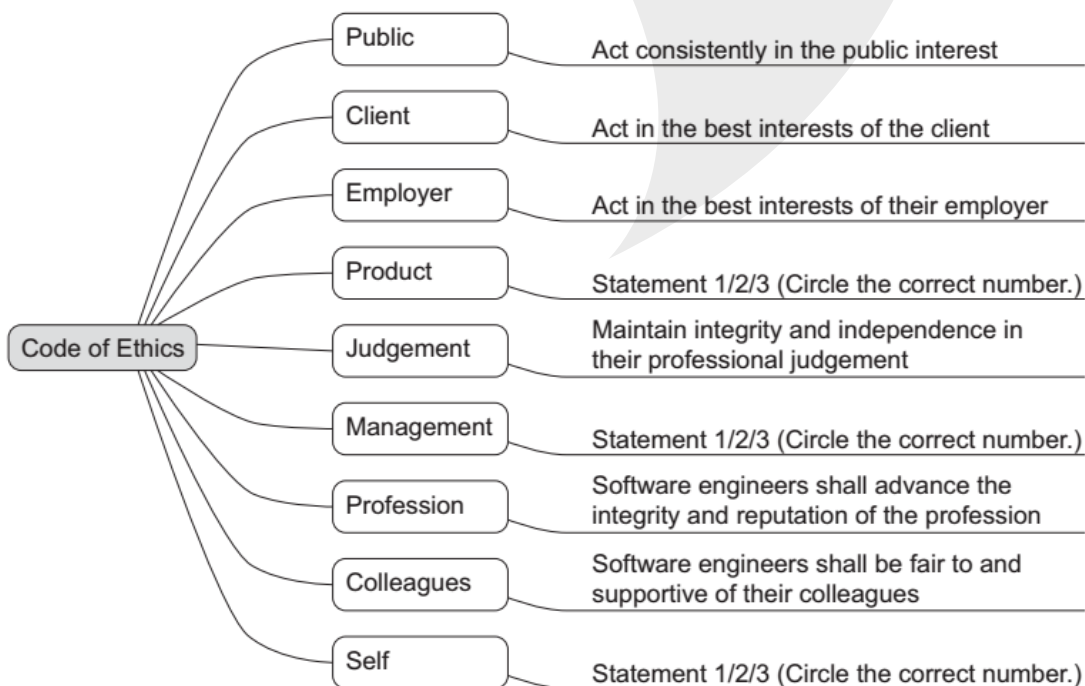

Statement 1: Team leaders should subscribe to and promote an ethical approach to the management of software development and maintenance.

Statement 2: Software engineers shall participate in lifelong learning regarding the practice of the profession.

Statement 3: Software and related modifications meet the highest possible standards.

a) These three statements need to be added to the diagram. Circle the correct numbers on the diagram to indicate the positions for Statement 1, Statement 2 and Statement 3. [2]

b) For each of these three workplace scenarios, unethical behaviour is demonstrated. Explain the principle(s) which are not being met.

i Workplace scenario 1

A large project is devolved to project teams, each led by a project leader. One project leader fails to inform his manager that he has major concerns that:

- their team's software contribution is taking much longer to write and test than anticipated
- they are consequently at risk of spending over their allocated budget. [3]

.....
.....

ii Workplace scenario 2

The software house is about to train a number of programmers in a new programming language. Two employees are refusing to attend the training. [2]

.....
.....

iii The company is developing some monitoring software which requires sensors placed in a nature reserve.

One employee considers the sensors will be a danger to some of the wildlife, but is told by his manager that the matter is none of his concern. [2]

.....
.....

2 A team of software engineers is developing a new e-commerce program for a client. State **three** of the principles of the ACM/IEEE Software Engineering Code of Ethics. Illustrate each one, with an example, describing how it will influence their working practices.

- 1
 - 2
 - 3
- [6]

3 Bobby is a senior programmer at a software house which produces intruder detection software. He also runs his own software company which develops and sells various computer applications. The following table shows seven activities which Bobby carries out.

Put a tick (✓) in the appropriate column to identify if the activity is ethical or unethical. [7]

Activity	Ethical	Unethical
Gives away passwords used in the intruder detection software		
Uses source code developed at the software house for the software he develops for his own company		
Insists that staff work to deadlines		
Turns down training opportunities offered by his employer		
Writes and sells software that reads confidential data from client computers		
Fakes test results of safety-critical software		
Has the software applications developed overseas for sale in his own country		

Candidate Example Response

Example candidate response – high

8 Five computing terms are described below.

Write the name of the term being described.

Software that anyone can download for free from the Internet and then use without having to pay any fees. The usual copyright laws apply and a user license is important.

Freeware

Software that gives the user the chance to try it out free of charge before actually buying it. The software is subject to the usual copyright laws. As a rule, not all the features found in the full version are available at this stage.

Shareware

Software where users have freedom to run, copy, change and adapt it. This is an issue of liberty and not of price since the software guarantees freedom and the right to study and modify the software by having access to the actual source code.

Free Software

Set of principles that regulates the use of computers in everyday life. This covers intellectual property rights, privacy issues and the effects of computers on society in general.

Computer Ethics

The taking of somebody's idea or software and claim that the idea or software code were created by the "taker".

Plagiarism

[5]

Examiner comment – high

This candidate managed to give the correct term for all 5 definitions.

Total mark awarded = 5 out of 5

Example candidate response – middle

8 Five computing terms are described below.

Write the name of the term being described.

Software that anyone can download for free from the Internet and then use without having to pay any fees. The usual copyright laws apply and a user license is important.

Free software

Software that gives the user the chance to try it out free of charge before actually buying it. The software is subject to the usual copyright laws. As a rule, not all the features found in the full version are available at this stage.

Shareware

Software where users have freedom to run, copy, change and adapt it. This is an issue of liberty and not of price since the software guarantees freedom and the right to study and modify the software by having access to the actual source code.

Freeware

Set of principles that regulates the use of computers in everyday life. This covers intellectual property rights, privacy issues and the effects of computers on society in general.

Computer ethics/
Laws

The taking of somebody's idea or software and claim that the idea or software code were created by the "taker".

Plagiarism

[5]

Examiner comment – middle

This candidate has made a common error and mixed up the definitions of freeware and free software.

Total mark awarded = 3 out of 5

Example candidate response – low

8 Five computing terms are described below.

Write the name of the term being described.

Software that anyone can download for free from the Internet and then use without having to pay any fees. The usual copyright laws apply and a user license is important.

..... Free software

Software that gives the user the chance to try it out free of charge before actually buying it. The software is subject to the usual copyright laws. As a rule, not all the features found in the full version are available at this stage.

..... Shareware

Software where users have freedom to run, copy, change and adapt it. This is an issue of liberty and not of price since the software guarantees freedom and the right to study and modify the software by having access to the actual source code.

..... Freeware

Set of principles that regulates the use of computers in everyday life. This covers intellectual property rights, privacy issues and the effects of computers on society in general.

..... Copyright law

The taking of somebody's idea or software and claim that the idea or software code were created by the "taker".

..... plagiarism

[5]

Examiner comment – low

This candidate has made the common error of mixing up the definitions of freeware and free software. They are also incorrect with Copyright law. This is one part of computer ethics but not the entirety, so it doesn't match the full definition.

Total mark awarded = 2 out of 5

Topical Past Papers

Q 2) Winter 2015 P13

4 (a) Computer ethics involves a number of different topics.

(i) A student made the following statement on an examination paper:

“It allows a user to have the freedom to run, copy, change and adapt the software and then pass it on to a colleague, friend or family member.”

Identify which computer term the student was describing.

..... [1]

(ii) Explain what is meant by computer ethics.

.....
.....
.....
.....
.....
.....
..... [3]

Q 3) Winter 2015 P11

13 Identify which **five** computer terms are being described below.

(a) A system designed to prevent unauthorised access to or from a private network or intranet; it examines all data traffic to and from the network and filters out anything that does not meet certain criteria.

..... [1]

(b) Software that can be used on a trial basis before buying the full version; it often does not include all the features of the full version or has a time limit before it stops working.

.....[1]

(c) A protocol for transmitting private documents via the Internet; it uses two keys to encrypt the data – a public key and a private key.

.....[1]

(d) A standard adopted by the electronic music industry for controlling devices that produce music, such as synthesisers and sound cards.

..... [1]

(e) A device that allows audio signals to be converted into electrical signals which can be interpreted by a computer after being converted into digital signals.

[1]

Examiners' Comments Question 13(a) (b) (c) (d) and (e)

Many candidates were able to gain at least two or three marks in this section. Some confused shareware for freeware or free software, demonstrating they were unsure of their knowledge in this area.

Q 4) Summer 2016 P11 & P13

1 Some software can be described as free, freeware or shareware.

Tick (✓) the appropriate boxes in the table below to show which features apply to these three types of software. [3]

Software feature	Free	Freeware	Shareware
Software source code can be freely accessed and modified as required			
All the features of the full version of the software are not made available; the full version needs to be purchased first			
The original software is subject to all copyright laws			
It is possible to distribute modified versions or copies of the software to friends and family			

Q 5) Summer 2016 P12

8 (a) **Five** statements and **three** types of software are shown below.

Draw lines to connect each statement with the correct type of software. [3]

Statement	Type of
Users have the freedom to pass on the software to friends and family as they wish.	
Users can download this software free of charge, but they cannot modify the source code in any way.	Free software
Users are allowed to try out the software for a trial period only before being charged.	Freeware
Users can study the software source code and modify it, where necessary, to meet their own needs, without breaking copyright laws.	Shareware
Users can obtain a free trial version of the software, but this often does not contain all the features of the full version.	

Q 8) Winter 2017 P12

11 Complete the paragraphs choosing the correct five terms from the list. Each term can only be used once:

- Ethics
- Hacking
- Shareware
- Freeware
- Malware
- Virus
- Free Software
- Plagiarism

Taking another person's work from the Internet and claiming it as your own is called..... . It is possible to protect your work online with copyright. One product that people may want to protect is software. does allow a person to share, copy and change software freely, but does not allow a person to do this legally. Software that has a licence allowing free use for a trial period is called The name given to this area of Computer Science is..... . [5]

Q 9) March 2018 P12 (India)

1 Some types of software can be described as free software or freeware. Draw lines to link each description to a correct type of software. A description can be linked to more than one type of software. [2]

Description	Type of software
Free to download	Free software
Code can be modified and redistributed	Freeware
Subject to copyright legislation	

Q 10) Summer 2019 P11

8 (c) The art gallery is concerned about computer ethics relating to its website.

Explain what is meant by computer ethics **and** why the art gallery is concerned about computer ethics.

.....
.....
.....
.....
.....
.....
.....
..... [4]

Q 11) Winter 2019 P13

6 Jesse is taking his Computer Science examination. He answers five questions about ethics.

(a) For the first question, he writes the answer: "This type of software can be copied and shared without the permission of the owner." State what Jesse is describing.

..... [1]

(b) For the second question, he writes the answer: "With this type of software, the owner still retains the copyright for the software, but he gives away copies of it for free."

State what Jesse is describing.

..... [1]

(c) For the third question, he writes the answer: "This type of software is often a trial version of the full software. To use the full version the user normally needs to pay a fee."

State what Jesse is describing.

..... [1]

(d) For the fourth question, he writes the answer: "This is when a person copies another person's computer program and tries to claim it as his own."

State what Jesse is describing.

..... [1]

(e) For the fifth question, he writes the answer:

“This is the legal protection that a person can obtain, to provide protection against his work being stolen.”

State what Jesse is describing.

..... [1]

Q 12) March 20 P12

8 A student website provides research support and software downloads.

(c) The website owners are also concerned about the ethical issues of copyright and plagiarism.

(i) State what is meant by the term copyright.

..... [1]

(ii) State what is meant by the term plagiarism.

..... [1]

Q 13) March 21 P12

7 Adeel has used a high-level language to program a mobile application.

(c) Adeel is considering distributing his application as free software or shareware.

Explain the difference between free software and shareware.

..... [5]

(d) Adeel is concerned about his application being plagiarised. Define the term plagiarism.

..... [1]

(e) Adeel copyrights his application. State why Adeel copyrights his application.

.....

.....

[1]

Marking Scheme

Q 2) Winter 2015 P13

4 (a) (i) Free software / open source software

- (ii) Any **three** from:
- Set of principles/laws that regulate the use of computers
 - Covers intellectual property rights (e.g. copying of software)
 - Privacy issues (e.g. accessing personal information)
 - Impact of computers on society (relevant examples can be credited)

Q 3) Winter 2015 P11

Q 4) Summer 2016 P11 & P13

1 1 mark for each correct column

Software feature	Free	Freeware	Shareware
Software source code can be freely accessed and modified as required	✓		
All the features of the full version of the software are not made available; the full version needs to be purchased first			✓
The original software is subject to all of the copyright laws		✓	✓
It is possible to distribute modified versions or copies of the software to friends and family	✓		

(1 mark)

(1 mark)

(1 mark)

Q 5) Summer 2016 P12

Page 8	Mark Scheme	Syllabus	Paper
	Cambridge IGCSE – May/June 2016	0478	12

8 (a) 1 mark for correct lines from each type of software

NOTE: all statements that are correct must be connected to the correct type of software for the mark to be awarded

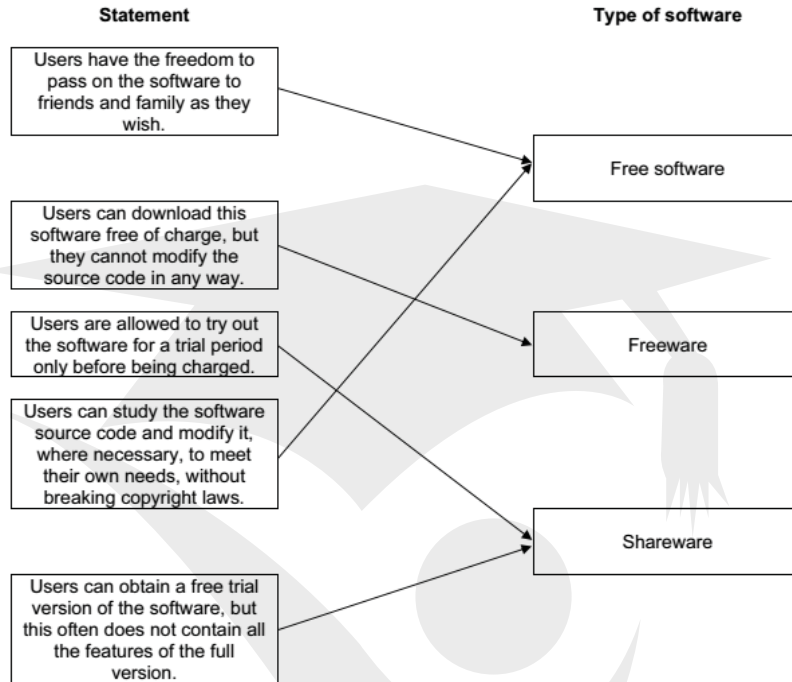

Page 9	Mark Scheme	Syllabus	Paper
	Cambridge IGCSE – May/June 2016	0478	12

(b) Any **three** from:

- That we should follow Copyright laws/intellectual property rights/work should not be stolen/plagiarised
- That we should follow Data Protection laws
- That we should not create or distribute malware//description of malware
- That we should not hack/crack other computers//description of hacking
- That we should protect our own computers against malware/hacking
- That we should consider privacy issues (when using social networking)
- That we consider anonymity issues (when using social networking)
- That we should consider environmental impacts when using computers
- Loss/creation of jobs from use of computers/robotics
- We should follow codes of practice (for creation of code e.g. ACM/IEEE)

[3]

Q 6) Winter 2016 P12

Page 10	Mark Scheme	Syllabus	Paper
	Cambridge IGCSE – October/November 2016	0478	12

12 Any four from:

- Freeware needs owner's permission to share/copy/amend whereas free software can be shared/copied/amended without permission
- Freeware the owner retains copyright / is subject to copyright whereas free software the owner releases copyright/ is not subject to copyright
- Freeware is normally provided without a fee whereas free software a fee may be charged
- Freeware is distributed without the source code whereas free software is distributed with the source code
- Freeware can be restricted in use e.g. non-commercial whereas free software can be used without restriction

NOTE: The question asks candidates to explain the differences, so each mark needs to have a comparison.

[4]

Q 7) Winter 2016 P11& 13

Page 9	Mark Scheme	Syllabus	Paper
	Cambridge IGCSE – October/November 2016	0478	13

- (d) – record (layer)
– handshake (layer)

[2]

11 Any six from:

- Help stop the misuse of computers
- The use of computers needs to be governed
- Help keep users safer when using computers
- Provides rules for using computers
- Help stop intellectual property theft
- Helps prevent the misuse of personal information
- Reference to laws (relevant example)
- Reference to security issues (relevant example)

NOTE: Answer must refer to the importance of ethics and be more than a description of ethics.

[6]

Q 8) Winter 2017 P12

11	1 mark for each correct missing word, in the correct order: ∞ Plagiarism ∞ Free software ∞ Freeware ∞ Shareware ∞ Ethics	5
----	---	---

Q 9) March 2018 P12 (India)

Question	Answer	Marks								
1	<table border="0" style="width: 100%;"> <tr> <td style="text-align: center;">Description</td> <td style="text-align: center;">Type of software</td> </tr> <tr> <td style="border: 1px solid black; padding: 2px;">Free to download</td> <td style="border: 1px solid black; padding: 2px;">Free software</td> </tr> <tr> <td style="border: 1px solid black; padding: 2px;">Code can be modified and redistributed</td> <td style="border: 1px solid black; padding: 2px;">Freeware</td> </tr> <tr> <td style="border: 1px solid black; padding: 2px;">Subject to copyright legislation</td> <td></td> </tr> </table> <p>1 mark for each 'Type of software' if correct lines are attached to it.</p>	Description	Type of software	Free to download	Free software	Code can be modified and redistributed	Freeware	Subject to copyright legislation		2
Description	Type of software									
Free to download	Free software									
Code can be modified and redistributed	Freeware									
Subject to copyright legislation										

Q 10) Summer 2019 P11

8(c)	Four from: <ul style="list-style-type: none"> • A set of guidelines • Rules/laws that govern the use of computers / by example • Tell people how to behave when using computers // helps keep users safe when using computers // by example • Art gallery could be subject to plagiarism / intellectual property theft • Art gallery could copyright their work (to make it illegal to steal it) 	4
------	---	---

Q 11) Winter 2019 P13

Question	Answer	Marks
8(a)	∞ Free software	1
8(b)	∞ Freeware	1
8(c)	∞ Shareware	1
8(d)	∞ Plagiarism // Intellectual property theft	1
8(e)	∞ Copyright	1

Q 12) March 20 P12

8(c)(i)	• A law/legislation that requires permission to use intellectual property / other people's work	1
8(c)(ii)	Any one from: <ul style="list-style-type: none"> • To claim other's work as your own • To use other people's work without consent / acknowledgement • Theft of intellectual property 	1

Q 13) March 21 P12

7(c)	Any five from: <ul style="list-style-type: none"> - Free software is distributed with the source code - ...whereas shareware is not distributed with the source code - Free software allows modification of the application - ...whereas shareware cannot be modified - Shareware normally allows a trial period for the end user // shareware has limited features to start with - Free software is often available free of charge - ...whereas shareware normally has a charge after trial period // shareware has charge to access all features // shareware makes you sign-up/register after trial period // shareware makes you sign-up/register to access all features 	5
7(d)	- Claiming another person's work as your own	1
7(e)	- To identify legal ownership // to claim ownership // protect intellectual property	1